

1	Verschlusskolben	2	4307	PE-HD			
1	Behaelter 204 ml	1	4398	PP			
Stk.	Benennung	Teil	Zeich.Nr./Norm	Werkst.	Rohabmessung	Bemerk.	
c.	AGZ nachgetragen.	16.07.10	Nieland				
b	1x Index AGZ hinzu	14.07.04	Nieland				
a	2 x Index,AGZ entfernt	22.11.01	Fe/Heuk				
Index	Aenderung	Datum	Name	Index	Aenderung	Datum	Name
AGZ	7036-007-00						
BGZ	7037-001-00 <input type="checkbox"/>						
	7036-036-00 <input type="checkbox"/>						
Copyright by RPC Wiko GmbH 50259 Pulheim (Germany)				Tel.02234/9858-0			
Gez.	31.01.00	Federau	FEK				
Gepr.	19.05.00	Prox					
Norm							
Massstab	Benennung			Zeichng.-Nr.			
1:1	Baugruppe 2			7035-009-02			
	Behaelter (204ml)			Ersatz fuer			
				STRIM 100 CAD-Zeichnung			
				DIN A3			

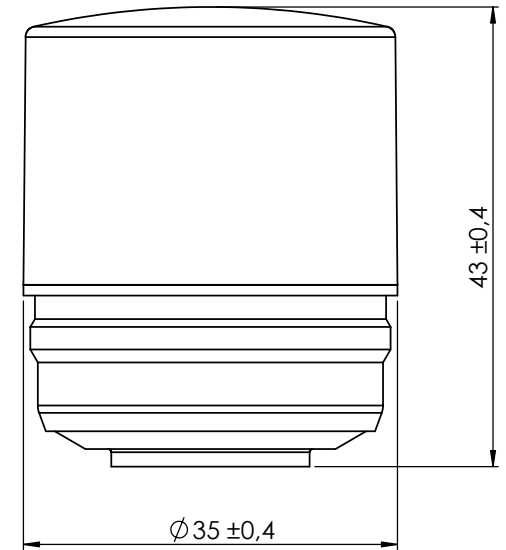

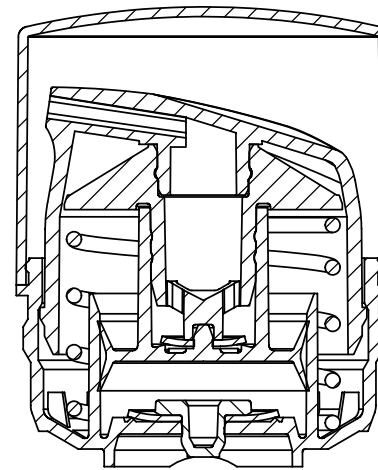

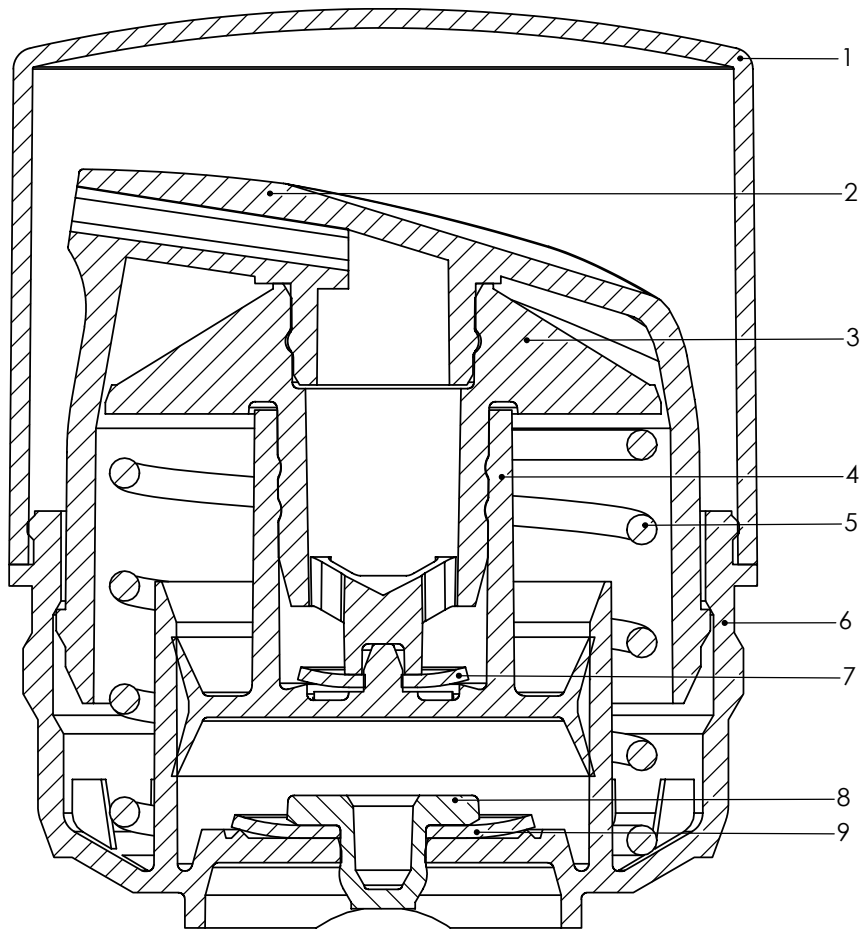

1	lower valve	9	4304		
1	plug	8	4301	PP	
1	upper valve	7	4149		
1	Adapter ring	6	4622	PP	
1	Spring	5	4482	Steel	
1	Pressure piston	4	4298	PE HD	
1	Fitting part	3	4621	PP	
1	Headpart	2	4620	PP	
1	Cap	1	F 4619	PP	
Stk.	Benennung	Teil	Zeichn. Nr.	Werkst.	Rohabmessung

Index	Änderung	Datum	Name	Index	Änderung	Datum	Name
AGZ	7039-005-00						
BGZ	7039-006-00						

Copyright by RPC WIKO GmbH & Co.KG 50250 Pulheim (Germany) Tel.02234/9858-0			
	Datum	Name	FEK
Gez.	26.10.05	D.Zwart	
Gepr.	26.10.05	Reinartz	
Norm			
Masstab	Benennung		Zeichng.-Nr.
4:1	Magic SL , Assembly Pump		7039-002-01
2:1	( Spring 23,5 N )		Ersatz für
			DIN A3

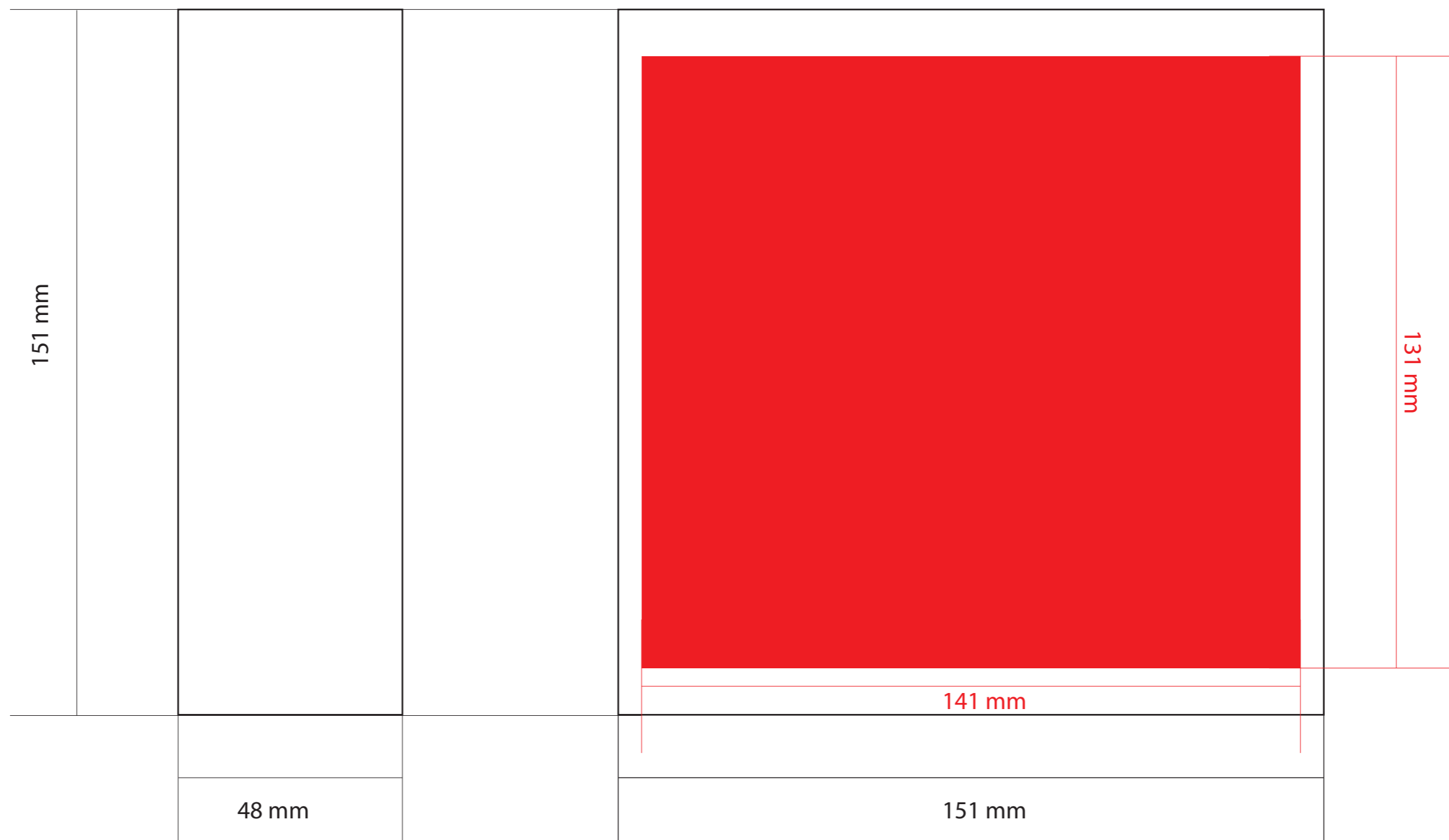



DATA: 15/03/2012	 <b>Vexel</b>
CODICE LD: 327-AS20	
CODICE CLIENTE:	
CLIENTE: Vexel	
PRODOTTO: Flacone AIRLESS MAGIC STAR 200 ml	
COLORE PRODOTTO: -	
VARIANTE: -	
COLORI STAMPA: -	
TECNICA STAMPA: Serigrafia	
NOTE: Area Serigrafabile	