

All rights remain with MegaPlast GmbH, also in the case of patent application. Power of disposition as well as copy- and handling-over rights remain with us. Alle Rechte bei MegaPlast GmbH, auch fuer den Fall von Schutzrechtsanmeldungen. Jede Veruegungsbefugnis, wie Kopier- und Weitergaberecht bei uns.

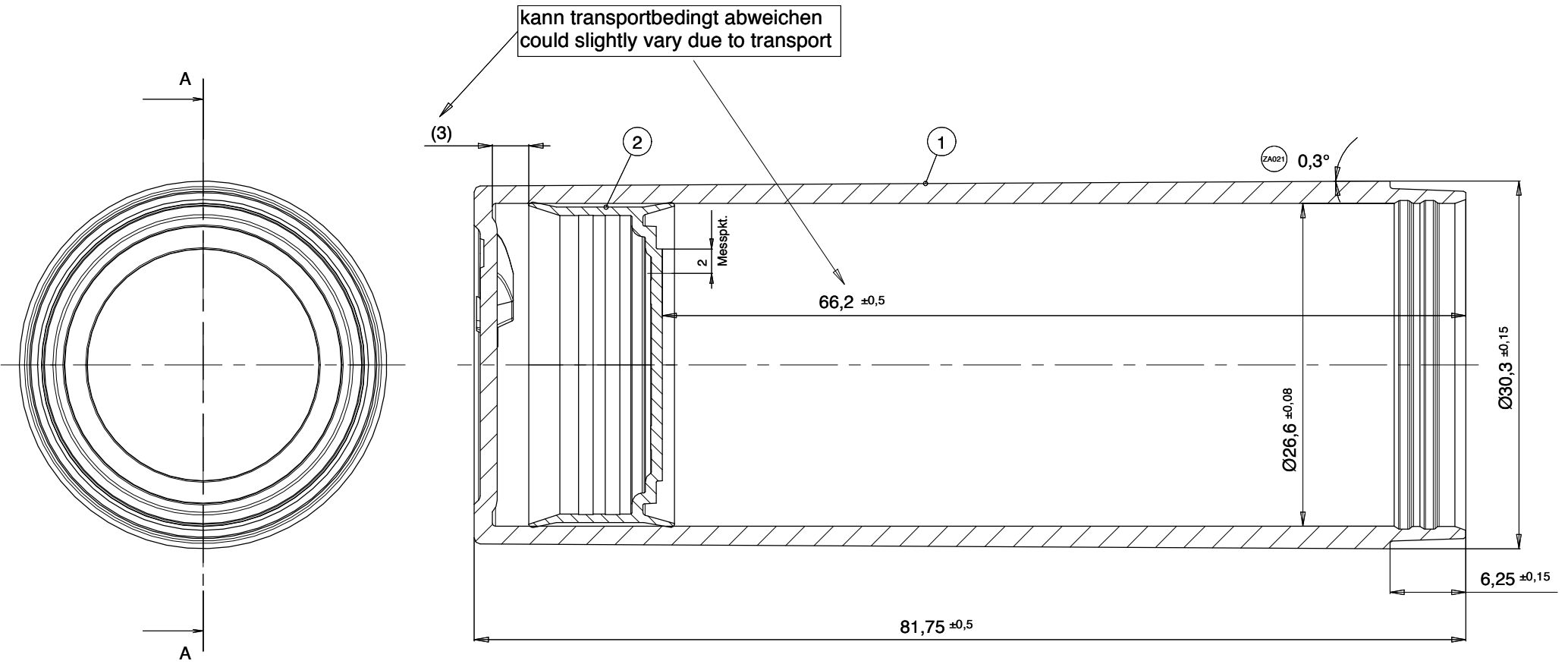

Unterliegt nicht dem Aenderungsdienst
DRAWING IS NOT SUBJECT
TO AUTOMATIC UP-DATING

Pos.	n	Beschreibung	Description	Item_No.	Code
2	1	Kolben 1501, rund	Piston 1501, round	AA00 1501	
1	1	Container ZAA-0E02 G, rund - 30ml	Container ZAA-0E02 G, round - 30ml	AA0E 1402	ZAA-0E02 G

DIN 16901 - 130		Micro	Maßstab 3:1 (-:-)
		Container ZAA-0E G, rund - 30ml	
		Container ZAA-0E G, round - 30ml	
		Teilenr. AA0E AA30	Code ZAA-0E G
Erstellt:	05.02.2008	Name	KH
Freigabe:	05.05.2011	UK	
AENDERUNGEN VORBEHALTEN (We reserve the right for technical improvement and modifications.)			

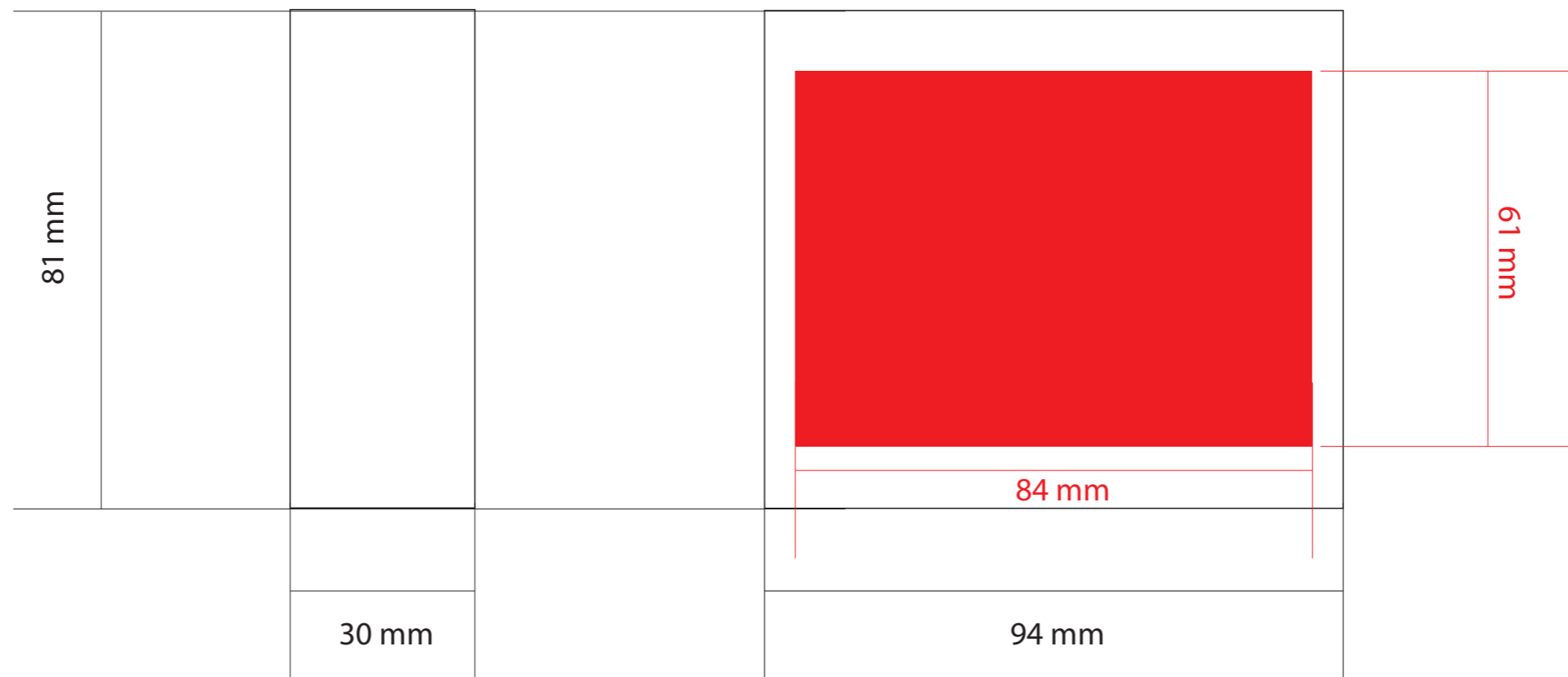

DATA: 15/03/2012	
CODICE LD: 327-AS24	
CODICE CLIENTE:	
CLIENTE: Vexel	
PRODOTTO: Flacone AIRLESS MICRO ROUND 30 ml	
COLORE PRODOTTO: -	
VARIANTE: -	
COLORI STAMPA: -	
TECNICA STAMPA: Serigrafia	
NOTE: Area Serigrafabile	