



Z i g n a g o V e t r o G r o u p



En France depuis 1892

**VERRERIES BROSSE**



En France depuis 1892

**VERRERIES BROUSSE**



For over a century, Verreries Brosse, has remained passionately dedicated to its traditional glass making savoir faire. Using its industrial expertise, Verreries Brosse, focuses on continually improving its Normandy factory to meet the growing and ever changing demands of the international beauty market.

Thanks to Verreries Brosse's expansive manufacturing processes which include both semi-automated and automated production capabilities, Verreries Brosse, offers a complete range of glass packaging items: high end perfume bottles and stoppers, Limited Edition series, EDT fragrance bottles, Factice display bottles for the fine fragrance market as well as make-up/skin care bottles and glass jars for the cosmetic market.

Verreries Brosse is world famous for its "crystal like" glass color and impressive glass distribution. Brosse's expert technicians assist in developing both custom and stock glass creations while integrating cutting edge decoration techniques to personalize and to differentiate new launches.

Verreries Brosse remains committed to exceeding its clients' expectations for: innovation, top quality, customer service, and on-time deliveries.

The Zignago Vetro Group acquired Verreries Brosse in 2002 and also purchased Huta Szkla Czechy in 2011. Now with factories in: Italy (Zignago Vetro), France (Verreries Brosse), and Poland (Huta Czechy), the Group, is globally positioned to supply both stock and glass containers to the fragrance and cosmetic market covering mass market through luxury sectors.

Depuis plus d'un siècle, conjuguant tradition et modernité, les verreries Brosse ont su faire évoluer leur outil industriel afin de l'adapter aux besoins du marché de la Beauté.

De par la diversité de ses procédés de fabrications, semi-automatique et automatique, Verreries Brosse développe une offre unique qui couvre l'ensemble des packagings standards verre qui composent la gamme de vos lignes : édition limitée, extrait, factice et Eau de Toilette pour la parfumerie avec aussi des flacons et pots cosmétiques.



Avec une offre de packagings standards constamment renouvelée à travers de nouveaux designs pour la parfumerie, la création de nouvelles gammes pour la cosmétique et des possibilités de différenciation de par l'éclat de notre verre et un éventail large de techniques de parachèvements ; les verreries Brosse se veulent être un acteur dynamique et créatif afin de satisfaire les besoins de vos marchés.

Une offre soutenue par des investissements en moyens et services industriels qui nous permettent de répondre à vos attentes en termes de compétitivité, réactivité, qualité et flexibilité.

Une offre des Verreries Brosse sur le segment haut de gamme renforcée depuis son rachat par le groupe italien Zignago Vetro en 2002, qui vient compléter celles des segments "lifestyle" de Zignago Vetro et "mass market" de l'entité Huta Czechy.



*Automatic manufacturing*  
*Produits en automatique*

EDT  
EAU DE TOILETTE  
**pag. 8**



*Semi-automatic manufacturing*  
*Produits en semi-automatique*

PERFUME  
EXTRAIT  
**pag. 62**

ESSENTIAL OILS  
ESSENCE  
**pag. 84**

STOPPERS  
BOUCHONS  
**pag. 86**

*Automatic  
manufacturing*



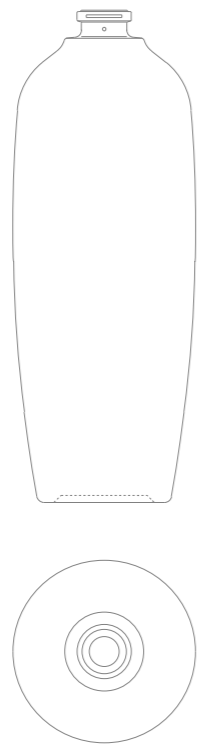

  
15 ml  
50 ml  
125 ml

  
FEA 13 or 15

  
49 gr  
128 gr  
227 gr

  
73,3 mm  
109,5 mm  
138,7 mm

  
29,3 mm  
40 mm  
51,4 mm



*n.1*  
Eau de Toilette



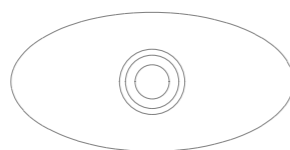
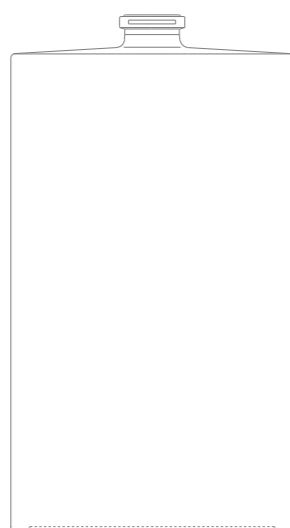

  
30 ml  
50 ml  
100 ml

  
FEA 15

  
94 gr  
135 gr  
201 gr

  
70,4 mm  
102,1 mm  
120,9 mm

  
27x55 mm  
27x55 mm  
32,6x66,2 mm



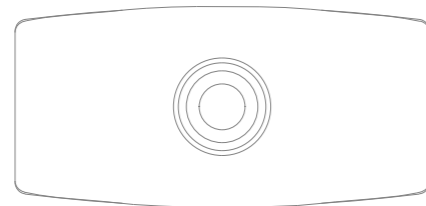
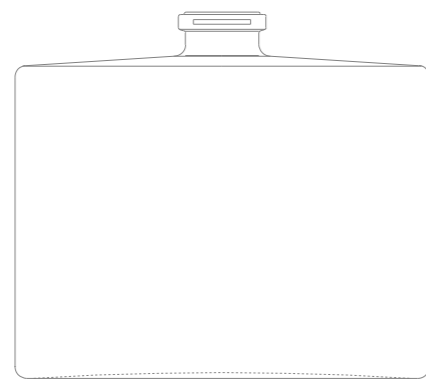

*n.2*  
Eau de Toilette



  
30 ml  
50 ml  
100 ml

  
FEA 15

  
126 gr  
187 gr  
344 gr

  
56,3 mm  
63,9 mm  
76,5 mm

  
31,2x62,6 mm  
35,7x72,3 mm  
45x88,5 mm



*n.3*  
Eau de Toilette



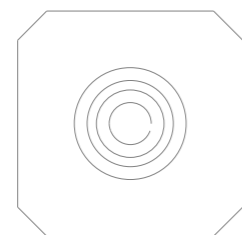
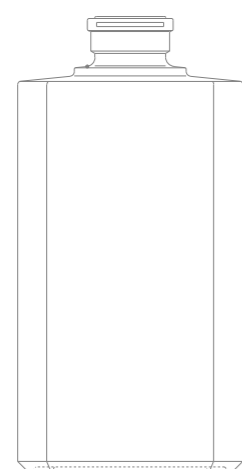

  
30 ml  
50 ml  
100 ml

  
FEA 18 or 20

  
98 gr  
143 gr  
216 gr

  
66,2 mm  
79 mm  
97,5 mm

  
36,5x36,5 mm  
41,5x41,5 mm  
48,3x48,3 mm



*n.5*  
Eau de Toilette

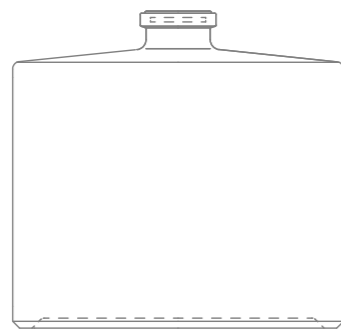

  
30 ml  
60 ml  
100 ml

  
FEA 15

  
70 gr  
136 gr  
190 gr





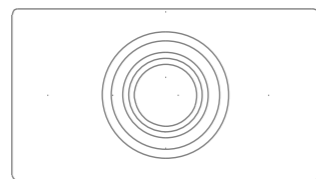
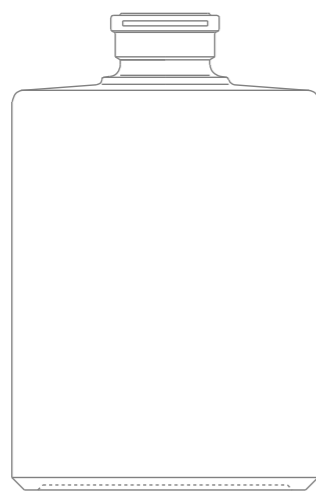

  
49,7 mm  
50,2 mm  
63,2 mm

  
51 mm  
63 mm  
66 mm



*n.6*  
Eau de Toilette



- 
  - 15 ml
  - 30 ml
  - 50 ml
  - 60 ml
  - 100 ml
  - 125 ml
- 
  - FEA 13 or 15
  - FEA 18 or 20
  - E4 or E5 or 18/415
- 
  - 48 gr
  - 83 gr
  - 119 gr
  - 154 gr
  - 208 gr
  - 255 gr
- 
  - 55,7 mm
  - 68,5 mm
  - 78,3 mm
  - 83 mm
  - 93,8 mm
  - 100,9 mm
- 
  - 20,6x38 mm
  - 25,3x46,1 mm
  - 28,8x51,3 mm
  - 31,6x55,5 mm
  - 35,8x63,3 mm
  - 39x68 mm
- 



*n.7*  
Eau de Toilette

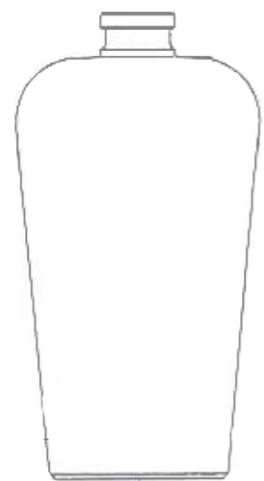

  
30 ml  
50 ml  
100 ml

  
FEA 15  
E4 or E5

  
82 gr  
100 gr  
175 gr

  
86,15 mm  
102,7 mm  
115,7 mm

  
33x45 mm  
36,7x50,2 mm  
45,4x62,1 mm



*n.8*  
Eau de Toilette



10 ml



FEA 13  
E4



35 gr



85,1 mm



20,5 mm



*n.12*  
Eau de Toilette

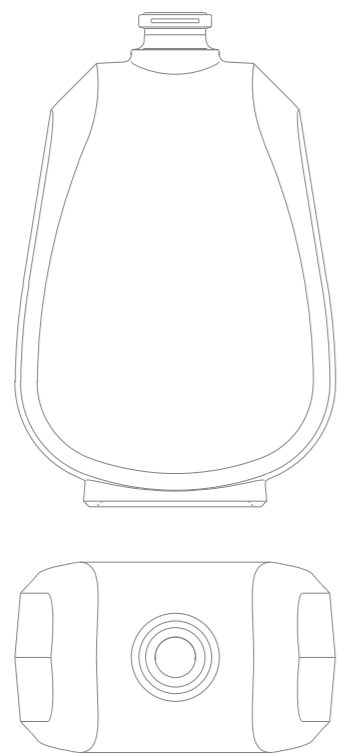

30 ml  
50 ml  
100 ml

FEA 15 or 18  
E4 or E5

85 gr  
95 gr  
155 gr

76,5 mm  
92,3 mm  
110 mm

30,6x48,5 mm  
30x52,2 mm  
37,5x65 mm



*n.13*  
Eau de Toilette



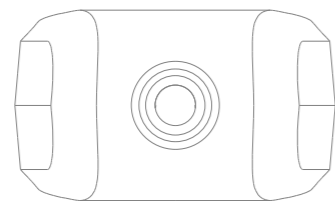
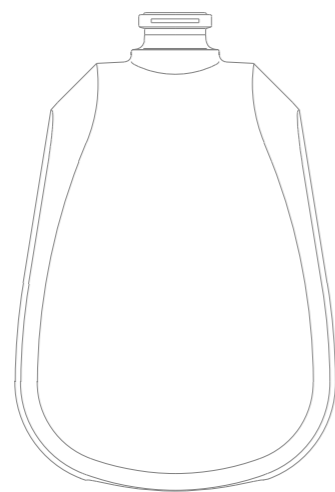



  
30 ml  
50 ml  
100 ml

  
FEA 15

  
75 gr  
105 gr  
192 gr

  
67,9 mm  
77,2 mm  
93,6 mm

  
26,2x50,7 mm  
30,3x58,6 mm  
37,5x72,5 mm



*n.13b*  
Eau de Toilette

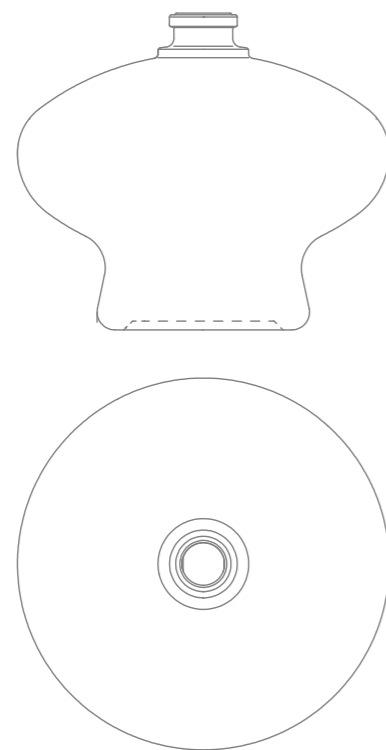

50 ml  
100 ml

FEA 15  
E4

122 gr  
225 gr

59,6 mm  
71,6 mm

68,8 mm  
84 mm



*n.14*  
*Eau de Toilette*

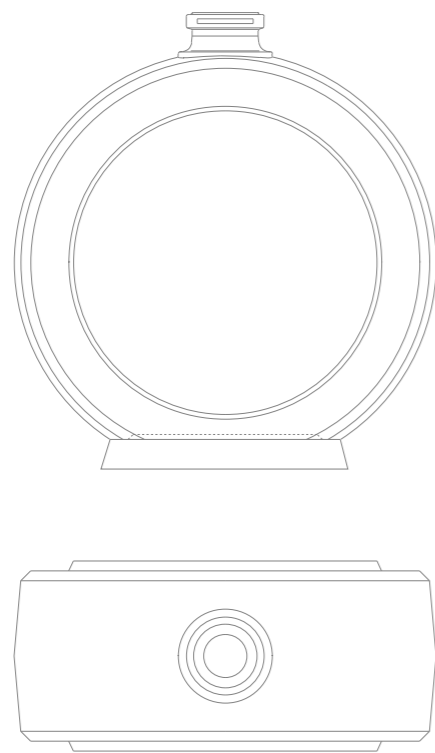

  
30 ml  
50 ml  
100 ml

  
FEA 15 or 18  
E4 or E5

  
78 gr  
78 gr  
165 gr

  
73,7 mm  
76,8 mm  
104,8 mm

  
27,4x56,9 mm  
26,2x66 mm  
32x84 mm



*n.16*  
Eau de Toilette

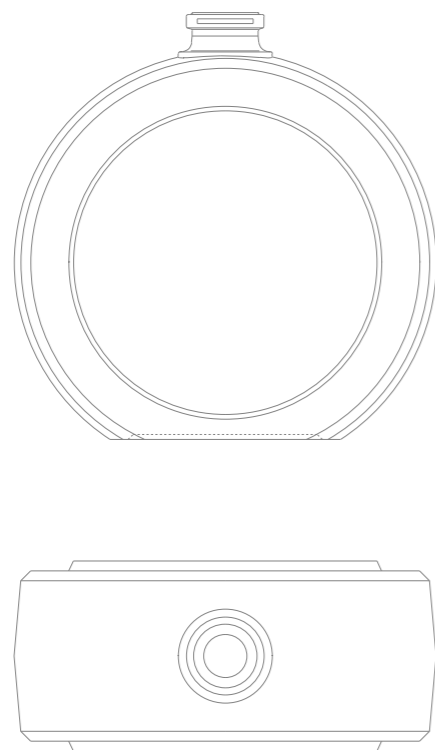

30 ml  
50 ml  
100 ml

FEA 15

78 gr  
110 gr  
183 gr

61,7 mm  
70,1 mm  
85,7 mm

26,7x59,3 mm  
30,8x68,2 mm  
37,5x83,1 mm



*n.16b*  
Eau de Toilette

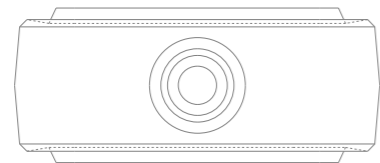
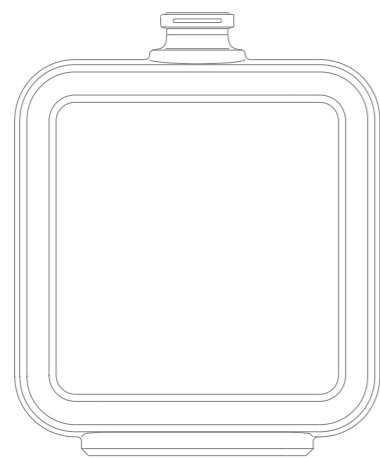

30 ml  
50 ml  
100 ml

FEA 15 or 18  
E4 or E5

87 gr  
95 gr  
170 gr

70,4 mm  
84,6 mm  
100 mm

25,4x50,5 mm  
25,4x60,2 mm  
32,3x74,2 mm



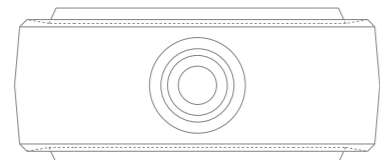
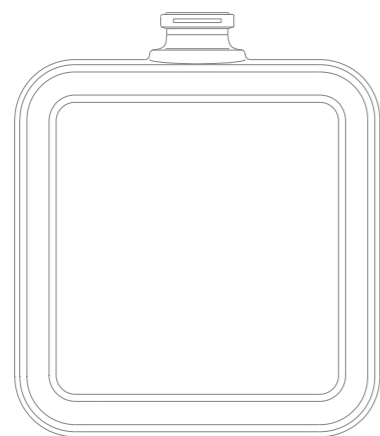

*n.17*  
Eau de Toilette



  
30 ml  
50 ml  
100 ml

  
FEA 15

  
73 gr  
98 gr  
177 gr

  
60,7 mm  
68 mm  
82,6 mm

  
25,4x51,9 mm  
28,9x59 mm  
35,9x73,3 mm



*n.17b*  
Eau de Toilette



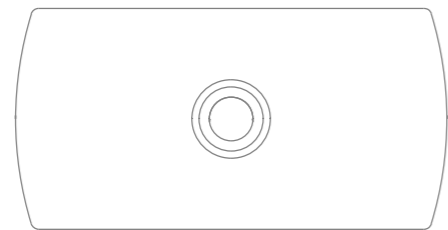
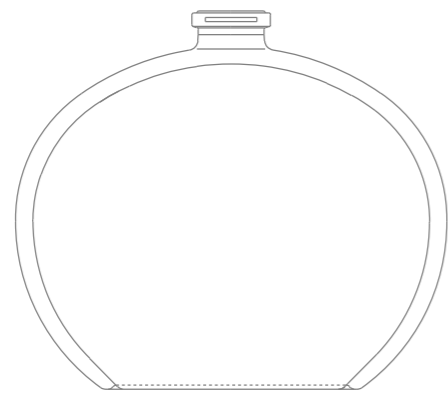

50 ml  
100 ml



FEA 15



132 gr  
210 gr



62 mm  
73,9 mm



35,5x69,4 mm  
43x84 mm



*n.20*  
Eau de Toilette

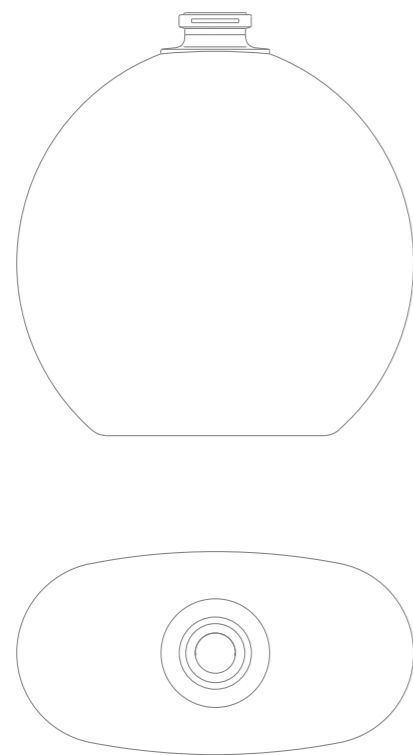

50 ml  
100 ml

FEA 15

129 gr  
204 gr

74,8 mm  
89,8 mm

35,5x69,4 mm  
43x84 mm



*n.21*  
Eau de Toilette

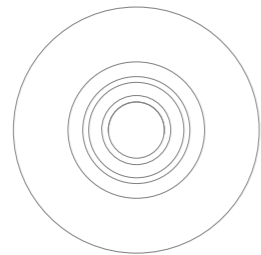
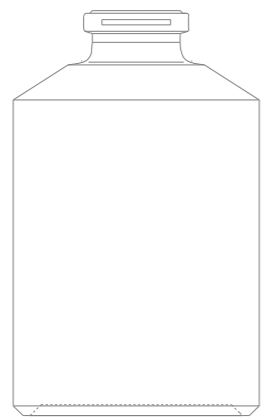

30 ml  
50 ml  
100 ml

E4  
FEA 15

70 gr  
120 gr

73,6 mm  
87,5 mm

42,5 mm  
51 mm



*n.30*  
*Eau de Toilette*

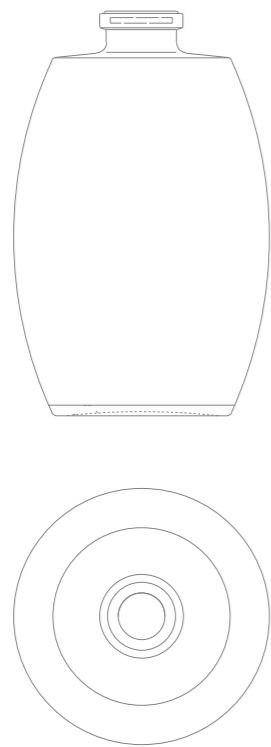

  
 30 ml  
 50 ml  
 100 ml

  
 FEA 15

  
 60 gr  
 90 gr  
 170 gr

  
 64,7 mm  
 74 mm  
 90,5 mm

  
 39,9 mm  
 46,9 mm  
 58 mm





*n.33*  
 Eau de Toilette



  
15 ml  
50 ml  
100 ml

  
FEA 13 or 15

  
50 gr  
140 gr  
240 gr

  
87,3 mm  
122,5 mm  
148,1 mm

  
19,2x24,8 mm  
27,6x35,7 mm  
43,8x33,8 mm



*n.44*  
Eau de Toilette

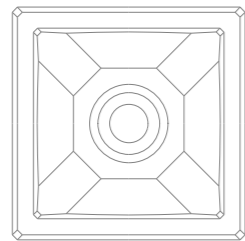
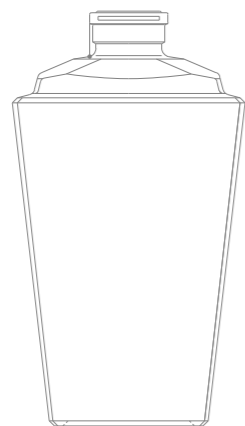

  
30 ml  
50 ml  
100 ml

  
FEA 15  
E4

  
80 gr  
95 gr  
180 gr

  
69,6 mm  
79,9 mm  
97,5 mm

  
39,3 mm  
43,9 mm  
54,7 mm



*n.50*  
Eau de Toilette



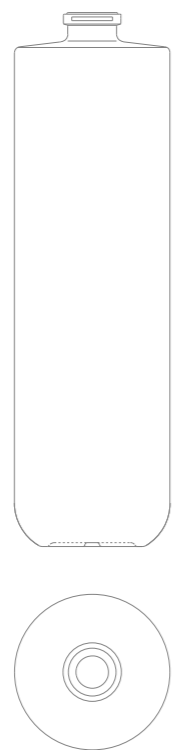

50 ml  
100 ml

FEA 15  
E4

75 gr  
150 gr

112,4 mm  
139,8 mm

32,4 mm  
40,7 mm



*n.51*  
Eau de Toilette

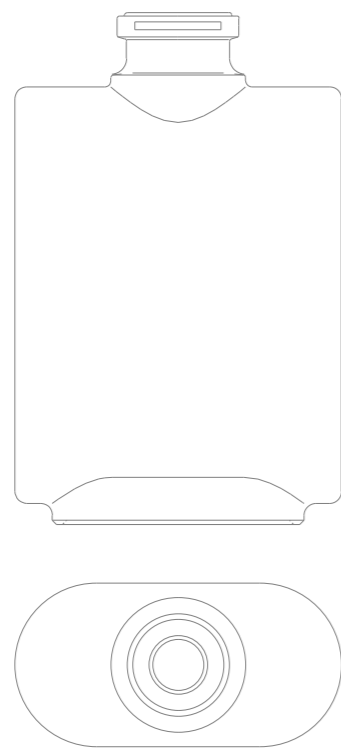

50 ml  
100 ml

FEA 18  
E5

90 gr  
183 gr

85,9 mm  
105,9 mm

27,3x54,5 mm  
34,2x69,5 mm



*n.92*  
Eau de Toilette

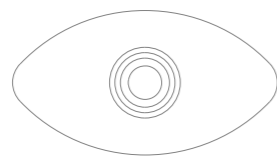
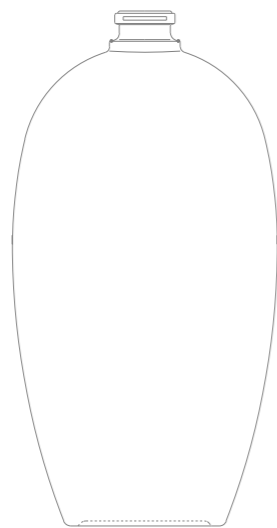

50 ml  
100 ml

E4  
FEA 15

100 gr  
180 gr

104,7 mm  
136,6 mm

29,9x54,4 mm  
36,8x67,4 mm



*n.97*  
Eau de Toilette

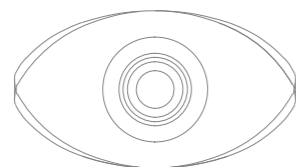
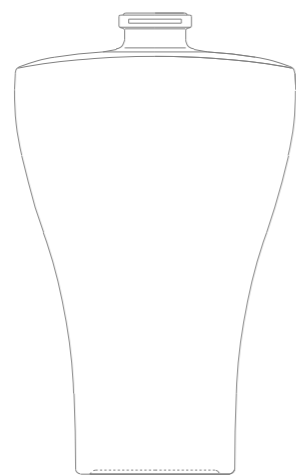

50 ml  
100 ml



FEA 15  
E4



111 gr  
200 gr



96,4 mm  
117,6 mm



33x58,8 mm  
40,8x72,6 mm



*n.98*  
Eau de Toilette

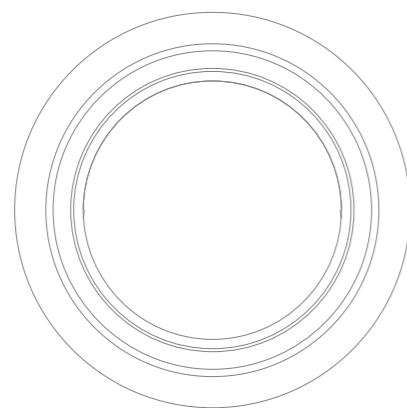
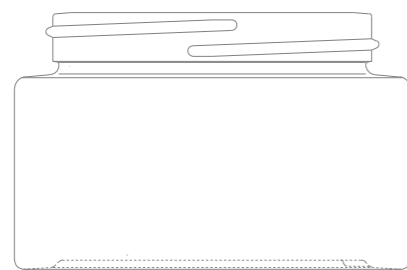

50 ml



GPI 400-58



170 gr



43,2 mm



66,6 mm



*n.40*

*Semi-automatic  
manufacturing*



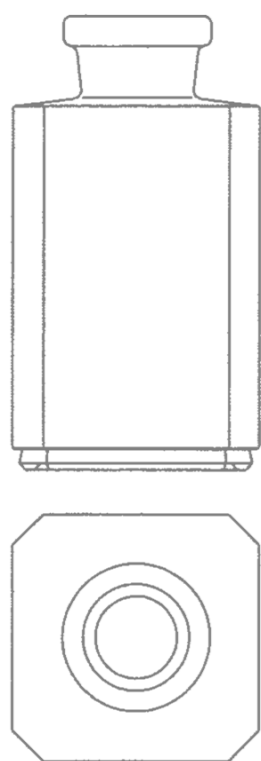

8 ml  
15 ml  
30 ml

8,5 mm  
10 mm  
12,5 mm

29 gr  
57 gr  
94 gr

44 mm  
55,3 mm  
67,1 mm

24,5 mm  
30 mm  
36,5 mm



*n.5*  
Perfume



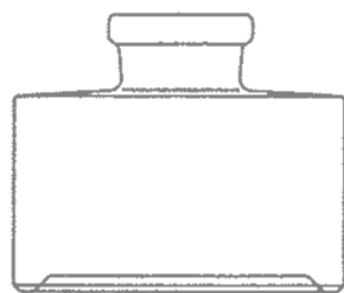

8 ml  
15 ml  
30 ml



8,5 mm  
10 mm  
12,5 mm



25 gr  
41,5 gr  
74 gr



29,5 mm  
35 mm  
43 mm



33,8 mm  
41,5 mm  
51 mm



*n.6*  
Perfume

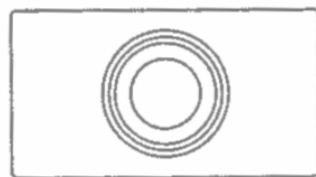
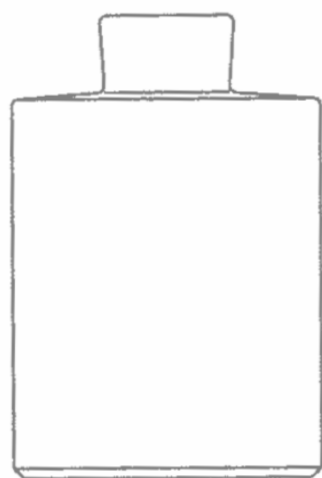

8 ml  
15 ml  
30 ml



8,5 mm  
10 mm  
12,5 mm



27 gr  
49 gr  
85 gr



46,5 mm  
57 mm  
70,5 mm



16,8x30,1 mm  
20,6x38 mm  
25,3x46,1 mm



*n.7*  
Perfume

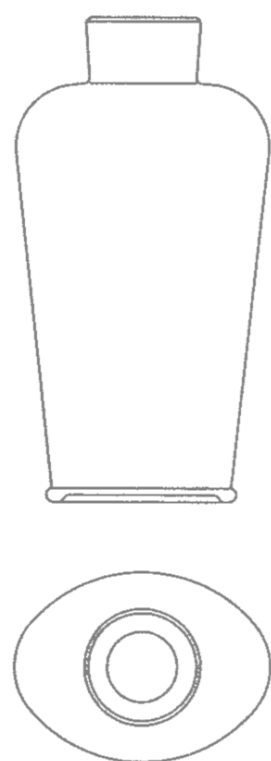

8 ml  
15 ml  
30 ml

8,5 mm  
10 mm  
12,5 mm

28 gr  
46 gr  
85 gr

59,5 mm  
70 mm  
88 mm

22x30 mm  
27x36,6 mm  
33x45 mm



*n.8*  
Perfume

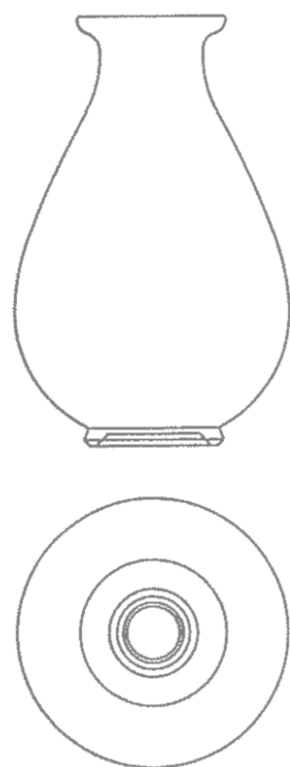

  
8 ml  
15 ml  
30 ml

  
8,5 mm  
10 mm  
12,5 mm

  
26,5 gr  
50 gr  
80 gr

  
47,8 mm  
59,7 mm  
72,2 mm

  
30,4 mm  
37,9 mm  
46 mm



*n.9*  
Perfume

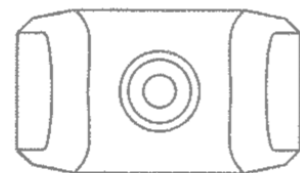
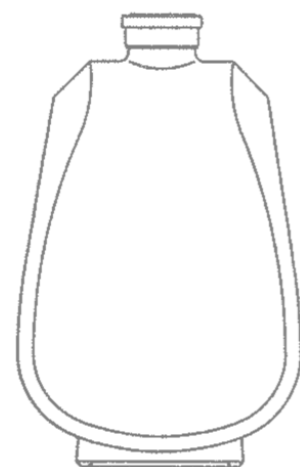

8 ml  
15 ml  
30 ml



8,5 mm  
10 mm  
12,5 mm



25 gr  
47,5 gr  
85 gr



48,7 mm  
59,7 mm  
72,7 mm



19,8x31,4 mm  
24,8x39,3 mm  
30,6x48,5 mm



*n.13*  
Perfume

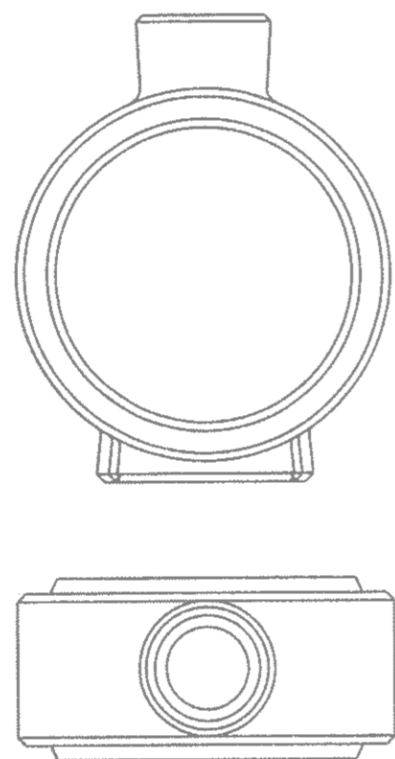

8 ml  
15 ml  
30 ml



8,5 mm  
10 mm  
12,5 mm



27,5 gr  
47 gr  
86 gr



47,7 mm  
57,2 mm  
69,6 mm



18,1x37,2 mm  
22,1x45,7 mm  
27,4x56,9 mm



*n.16*  
Perfume

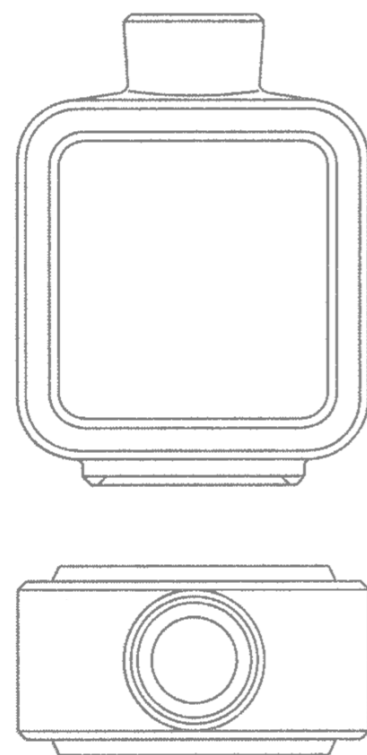

8 ml  
15 ml  
30 ml

8,5 mm  
10 mm  
12,5 mm

27,5 gr  
48 gr  
87 gr

46,1 mm  
55 mm  
69,1 mm

18,1x33,5 mm  
22,1x41 mm  
27,4x50,5 mm



*n.17*  
Perfume



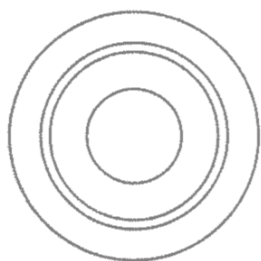
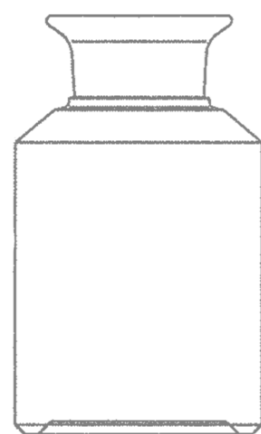

15 ml  
30 ml

10 mm  
12,5 mm

30 gr  
60 gr

52,2 mm  
66,7 mm

31,5 mm  
38 mm



*n.30*  
*Perfume*

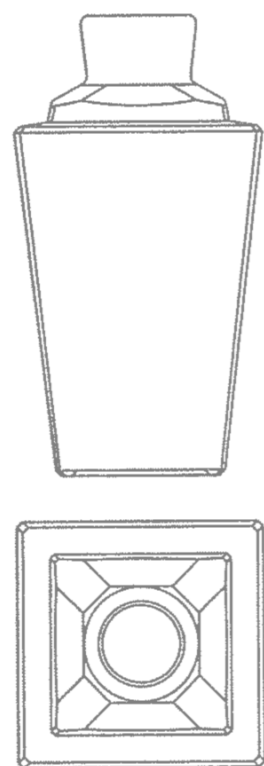

8 ml  
15 ml  
30 ml

8,5 mm  
10 mm  
12,5 mm

27,5 gr  
47 gr  
80 gr

49 mm  
59,5 mm  
71,8 mm

26,4 mm  
32,1 mm  
39,3 mm



*n.50*  
*Perfume*

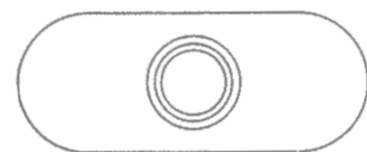
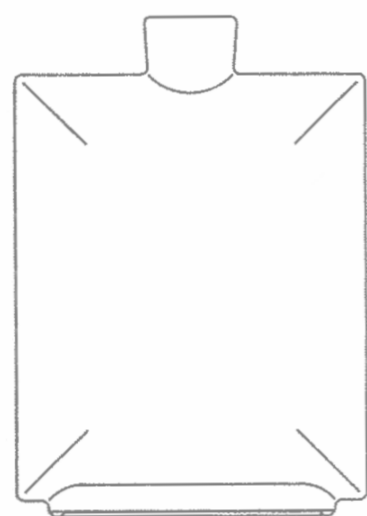

8 ml  
15 ml



8,5 mm  
10 mm



35 gr  
69 gr



45,1 mm  
54,5 mm



17,7x44,2 mm  
22x55 mm



*n.92*  
*Perfume*

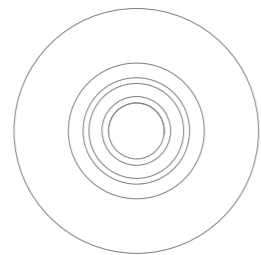
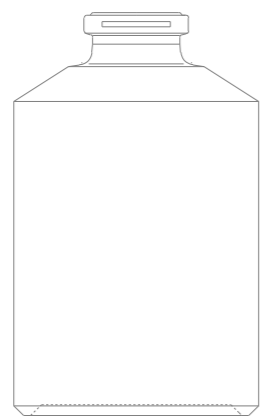

5 ml  
15 ml  
30 ml  
60 ml  
125 ml  
250 ml  
500 ml  
1000 ml



42 mm  
52,2 mm  
66,7 mm  
80,7 mm  
107,9 mm  
130,9 mm  
166,4 mm  
206,9 mm



PH 18/E 18  
E18  
E22  
PE7



23,5 mm  
31,5 mm  
38 mm  
45,2 mm  
54 mm  
66,6 mm  
82 mm  
100 mm



17 gr  
30 gr  
60 gr  
86 gr  
135 gr  
255 gr  
420 gr  
750 gr



*n.30*  
Essential oils



n° 205



n° 206



n° 216



n° 219



n° 207



n° 208



n° 223



n° 225



n° 211



n° 212



n° 257









Stoppers



## PRODUCTS INDEX INDEX DES PRODUITS

<i>Eau de Toilette n.1</i>	<i>pag. 9</i>
<i>Eau de Toilette n.2</i>	<i>pag. 11</i>
<i>Eau de Toilette n.3</i>	<i>pag. 13</i>
<i>Eau de Toilette n.5</i>	<i>pag. 15</i>
<i>Eau de Toilette n.6</i>	<i>pag. 17</i>
<i>Eau de Toilette n.7</i>	<i>pag. 19</i>
<i>Eau de Toilette n.8</i>	<i>pag. 21</i>
<i>Eau de Toilette n.12</i>	<i>pag. 23</i>
<i>Eau de Toilette n.13</i>	<i>pag. 25</i>
<i>Eau de Toilette n.13b</i>	<i>pag. 27</i>
<i>Eau de Toilette n.14</i>	<i>pag. 29</i>
<i>Eau de Toilette n.16</i>	<i>pag. 31</i>
<i>Eau de Toilette n.16b</i>	<i>pag. 33</i>
<i>Eau de Toilette n.17</i>	<i>pag. 35</i>
<i>Eau de Toilette n.17b</i>	<i>pag. 37</i>
<i>Eau de Toilette n.20</i>	<i>pag. 39</i>
<i>Eau de Toilette n.21</i>	<i>pag. 41</i>
<i>Eau de Toilette n.30</i>	<i>pag. 43</i>
<i>Eau de Toilette n.33</i>	<i>pag. 45</i>
<i>Eau de Toilette n.44</i>	<i>pag. 47</i>
<i>Eau de Toilette n.50</i>	<i>pag. 49</i>
<i>Eau de Toilette n.51</i>	<i>pag. 51</i>
<i>Eau de Toilette n.92</i>	<i>pag. 53</i>
<i>Eau de Toilette n.97</i>	<i>pag. 55</i>
<i>Eau de Toilette n.98</i>	<i>pag. 57</i>
<i>Essential oil n.30</i>	<i>pag. 85</i>
<i>Jar n.40</i>	<i>pag. 59</i>
<i>Perfume n.5</i>	<i>pag. 63</i>
<i>Perfume n.6</i>	<i>pag. 65</i>
<i>Perfume n.7</i>	<i>pag. 67</i>
<i>Perfume n.8</i>	<i>pag. 69</i>
<i>Perfume n.9</i>	<i>pag. 71</i>
<i>Perfume n.16</i>	<i>pag. 75</i>
<i>Perfume n.13</i>	<i>pag. 73</i>
<i>Perfume n.17</i>	<i>pag. 77</i>
<i>Perfume n. 30</i>	<i>pag. 79</i>
<i>Perfume n.50</i>	<i>pag. 81</i>
<i>Perfume n.92</i>	<i>pag. 83</i>
<i>Stoppers</i>	<i>pag. 86</i>

## LEGEND LÉGENDE

	<b>Capacity</b> Capacité
	<b>Type of finish</b> Type de bague
	<b>Glass weight</b> Poids du verre
	<b>Total height</b> Hauteur totale
	<b>Maximum diameter</b> Diamètre maximum
	<b>Item normally available</b> Article normalement disponible
	<b>Item available in scheduled periods of time</b> Article disponible en périodes programmées
	<b>Item available only on order and for minimum quantities</b> Article disponible seulement sur commande et pour quantités minimum

## GENERAL NOTES NOTES GÉNÉRALES

All dimensions and capacities shown in this catalogue are approximate and within tolerances stated in the technical drawings.

We reserve the right to modify, cancel or replace any item shown in this catalogue, without prior notice.

Les dimensions et les capacités sont approximatives dans les tolérances prévues sur le plan technique.  
Tout changement ou substitution des articles présentés dans ce catalogue peut être effectué sans avis préalable.







VERRERIES BROSSE S.A.S.  
*Part of the Zignago Vetro Group*  
9, ROUTE DU COLONEL MARCEL MORAINE, 92360 Meudon-la-Forêt, France  
Tel. (+33 01) 41 36 07 50 / Fax. (+33 01) 41 36 07 59  
e-mail: [info@verrieresbrosse.com](mailto:info@verrieresbrosse.com)

Factory and Head Office:  
34 rue Théodule Gérin, F - 76390 VIEUX ROUEN sur BRESLE  
Tel : +33 (0)2 35 93 45 02 / Fax : +33 (0)2 35 94 69 44

BROSSE USA  
West coast : Tel. 925-756-7471 / e-mail: [leebusa@aol.com](mailto:leebusa@aol.com)  
East coast : Tel. 908-635-1161 / e-mail: [db@brosseusa.com](mailto:db@brosseusa.com)