

# Digital Cutting Software Zünd Cut Center

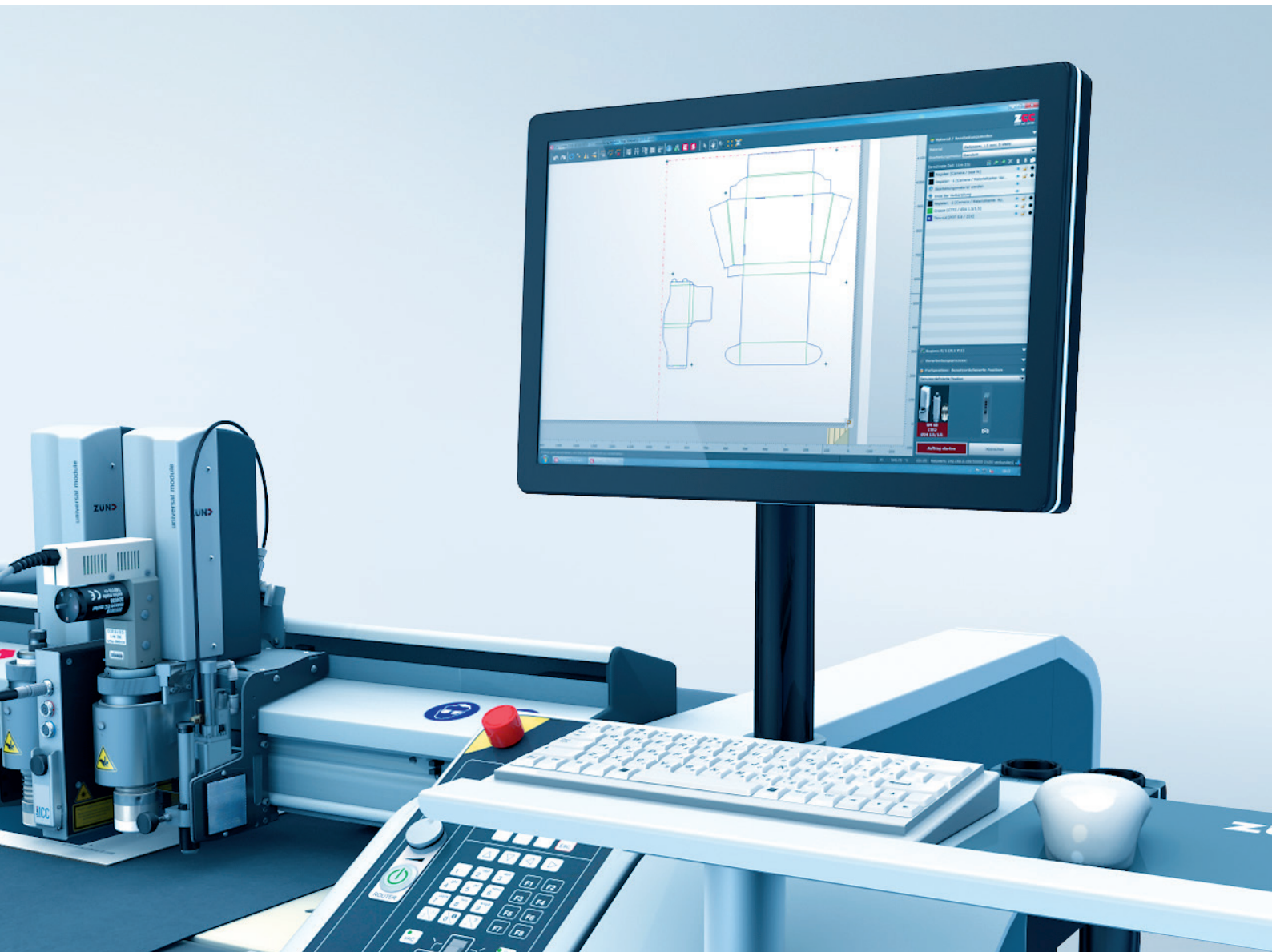

Your first choice in digital cutting.

# Digital Cutting Software for pros by pros



## Zünd Cut Center - ZCC

ZCC Digital Cutting Software is completely tailored to our customers' needs - a tool for pros by pros.

As complement to Zünd cutting/routing systems, ZCC is the backbone of your digital cutting workflow.

Zünd cutting systems together with ZCC as control center guarantee an optimal workflow from original file to finished product. This manifests itself in unsurpassed productivity and superior quality. Zünd Cut Center is designed to prepare cutter-ready files created in commonly used design programs such as Adobe® Illustrator®. Files from many popular RIP and nesting programs can be processed without additional manipulation.

The ZCC permits seamless integration in your digital workflow and supports the user in every phase of production.

## Production-time calculation

Production time is a key component in production planning. To keep you from having to time each job with a stopwatch, the Cut Queue keeps track of time for each phase of the job. Even while jobs are in the queue, you can see the estimated time it will take for processing them.

This provides you with the tools, e.g. to efficiently plan your daily production. Once the job is completed, the actual production time is saved in the cut data. This information may be used later on for invoicing or for planning recurring jobs.

**Material/cutting mode**

Material: Corrugated; 3 mm; B-Flute

Cutting mode: quality

Estimated time: 2h 38m 27s

- Register [Camera / best fit]
- Thru-cut: Cutting Lines [POT 0.6 / Z20]
- Crease: Folding Lines [CTT1 / Ø61 R0.5 1...

# ZCC production workflow prepared for the future

Before now digital cutting workflows required any number of manual steps. Looking to the future, it is becoming increasingly obvious that the highest degree of automation will be necessary

to produce cost-effectively and remain competitive. Zünd has devoted itself to this topic for years, and complete workflow automation remains our primary objective.

Pos	Order ID	Status	Copies	Material	Estimated time
	Jensen 444	ready	0/30	Acrylic; 3 mm; Cast (GS) & Extruded (XT)	2h 17m 10s
	Jensen 123	ready	53/70	Corrugated sandwich; 16 mm; Hon...	1h 43m 49s
1	Hansen 3452	ready	3/20	Corrugated; 3 mm; B-Flute	5m 1s
2	Hansen 321	ready	0/100	Corrugated; 3 mm; B-Flute	11h 5m 43s
3	BC-14538	ready	13/50	Corrugated; 3 mm; B-Flute	2h 26m 15s
	BC-14538	ready	0/1	Corrugated; 1.5 mm; E-Flute	7m 32s
	4588456	ready	0/1	Expanded PVC; 3 mm; Forex®, Sintra®, Kömatex®, Celtec®	10m 58s

Order ID	Date/time	Material	Production time
Jensen 123	11.02.2013 14:16:42	Acrylic; 3 mm; Cast (GS) & Extruded (XT)	5m 1s
Miller 3467	11.02.2013 14:02:44	Corrugated; 3 mm; B-Flute	11h 5m 43s
4588456	11.02.2013 14:01:56	Expanded PVC; 3 mm; Forex®, Sintra®, Kömatex®, Celtec®	2h 26m 15s

The Cut Queue offers comprehensive import-/export options and necessary interfaces for communicating with e.g. ERP/CRM/RIP and other software. Take advantage of this open architecture to optimize your production workflow. Compile cost data, generate offers, etc., from a central source!

Production-ready jobs are listed and can be further managed in the Cut Queue. The Cut Queue also provides important, job-relevant information such as order numbers, due dates, and material references. A large display area facilitates job control and identification. Already in this phase, you can use the „estimated production time“ to coordinate your production schedule. Last-minute corrections can be made anytime in the Cut Editor. Job selection occurs either manually or via barcode reader.

## How does the Cut Queue help you automate your production workflow?

- Seamless preparation of cut file from RIP
- Open jobs with barcode reader
- Batch processing for automated production of multiple jobs
- Hotfolders for efficient import of jobs with repeat scenarios
- Email notification in case of error or required user intervention
- Comprehensive search functions and filter options
- Standardized user interface for data exchange with ERP/CRM, etc.

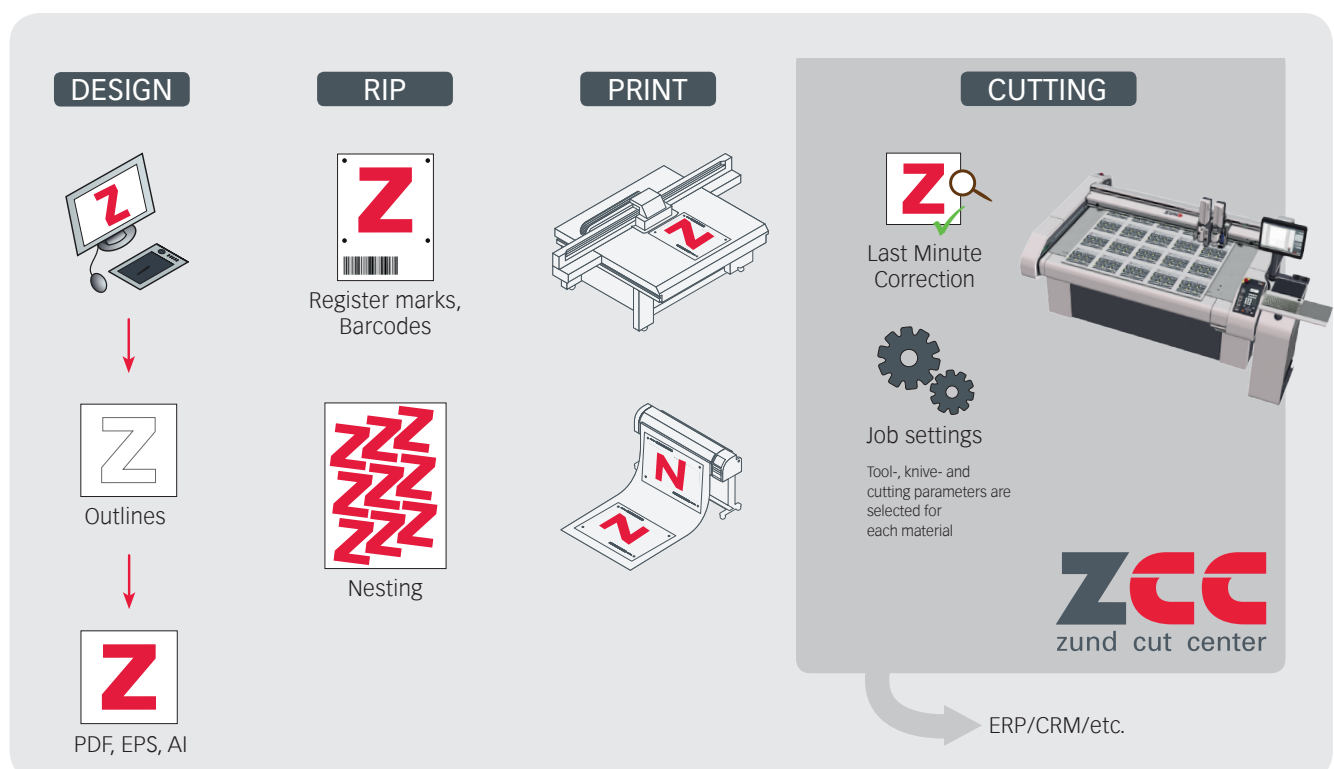

# Our Know-How helps your productivity

## Registration

The precise placement of cut paths on the substrate is critical. The Zünd ICC camera system in combination with Zünd Cut Center guarantees perfect registration and alignment of contours.

Many jobs require positioning as well as compensation. Based on the compensation method you choose, complex algorithms provide the best-possible placement and cut data optimization for

the job at hand. This allows for highly accurate cutting even with challenging materials, e.g. textiles that are subject to significant distortions.

The ICC camera is equipped with precise optics. Register marks and material edges are captured automatically. The system is designed to provide perfect registration even with poor color contrast, reflective materials, or low ambient lighting.

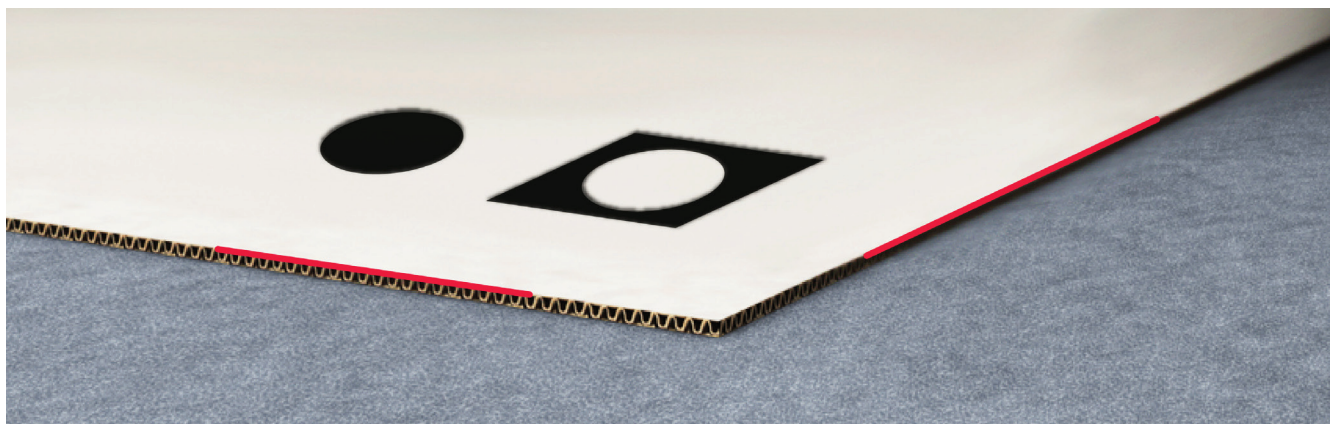

## ZCC material database

A comprehensive material database is the core of the ZCC software. It contains the best processing methods and parameters for a multitude of materials.

Before a material is added to the database, it undergoes extensive testing in the Zünd R&D department. This ensures the material will be processed with the best-possible methods and perfectly coordinated parameters. Only thoroughly proven methods are utilized and the utmost care is taken to maximize the longevity of router bits and cutting blades.

The system suggests optimal combinations of tools and inserts for each material. If you do not happen to have the suggested blade, ZCC will automatically propose possible alternatives.

The ZCC material database can be expanded individually by the user. New materials can be added with a few mouseclicks. Once these user-defined entries are made, they remain available for future jobs.

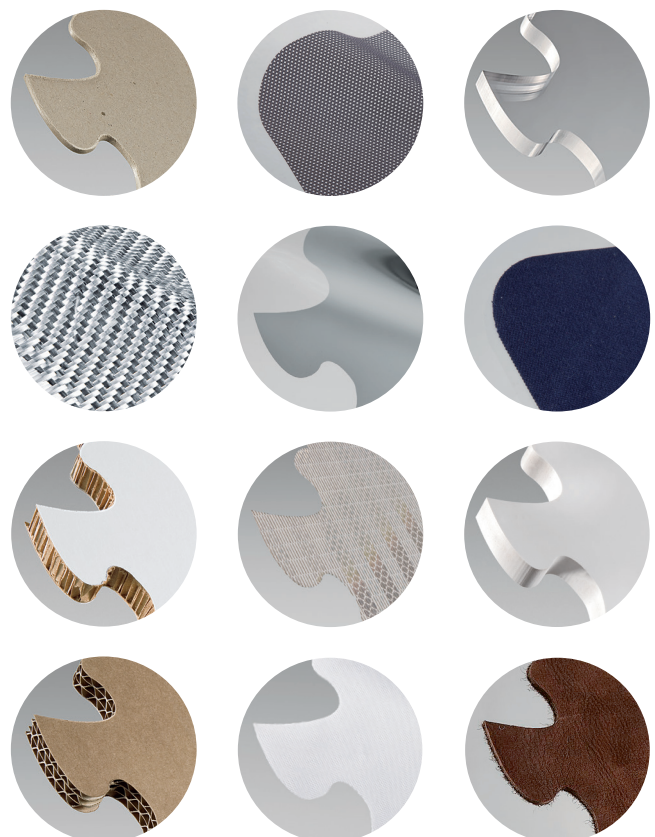

# Step by step to perfect results

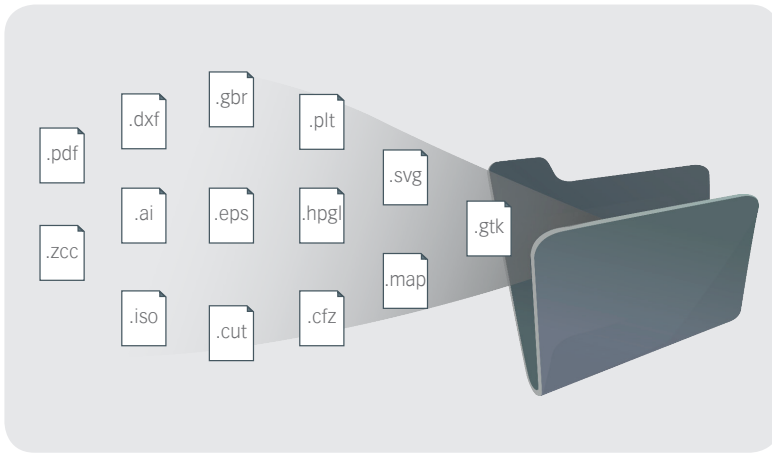

## File import

ZCC interfaces with all commonly used RIP systems. In some cases, as a result of particularly close cooperation with RIP vendors, the integration may even be seamless.

In addition, ZCC supports numerous vector-based file formats. Hot folders or Cut Editor can be used to automatically convert and import cut files in different original file formats. Files that are sent to a hot folder are automatically converted for processing and forwarded to the Cut Queue.

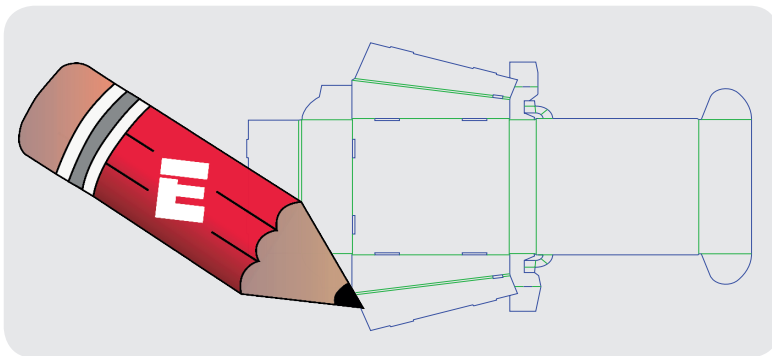

## File preparation

The Cut Editor offers numerous functions for preparing cut files easily and efficiently. This gives designers and operators a full-fledged tool for generating cut data and assigning important characteristics such as job processes, processing modes, etc.

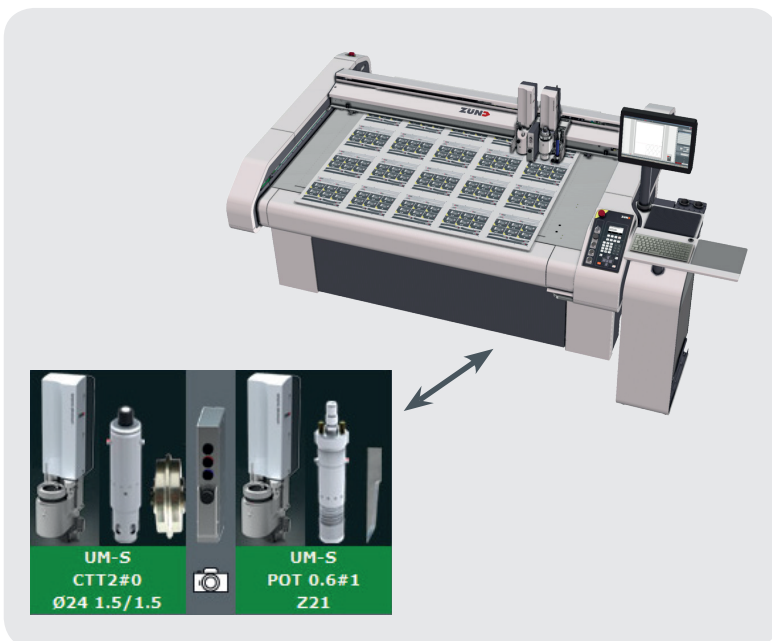

## Control Center

Cut Center provides the interface between user and machine. The software guides you in a few steps from the prepared file to the start of cutting/processing and supports you in each task.

- Assign job-specific production processes
- Install proposed tool configuration

Before starting to cut the job, you have the option to perform a simulation to verify all the settings. Once you give the OK to proceed, the system reads the register marks and production can begin. If any user intervention becomes necessary during production, the system sends out an email notification.

# Userfriendly and intuitive a sure path to success

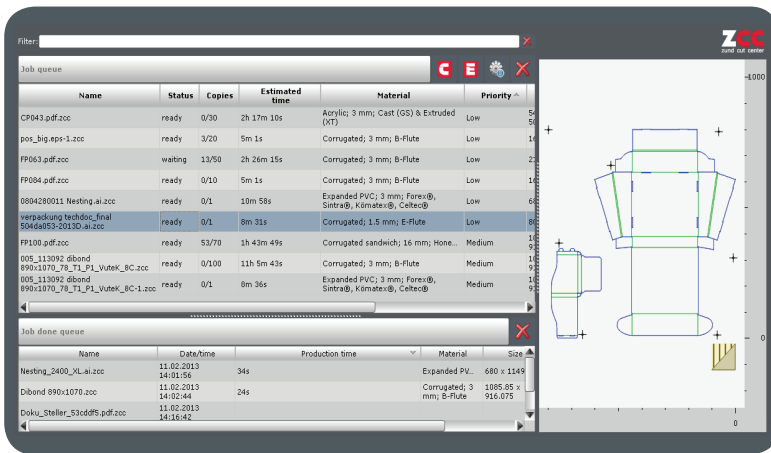

## Cut Queue

- Overview and sorting of pending and finished jobs
- Select jobs via barcode reader
- Job preview
- Estimated production time
- Batch processing
- Email notification

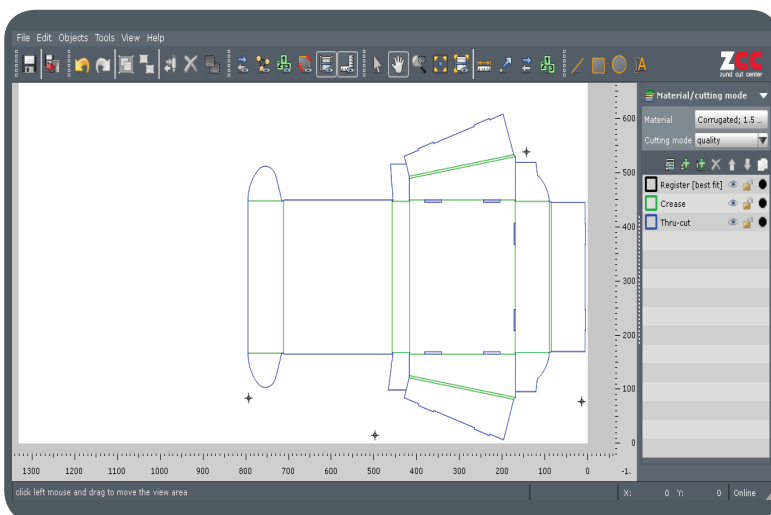

## Cut Editor

- Expanded editing tool for last-minute cut-file corrections
- Basic drawing tools
- Close open contours
- Overcut compensation
- Optimize processing times:
  - Control cut sequence
  - Control cut direction
  - Automatically set start point
- Comprehensive file import options

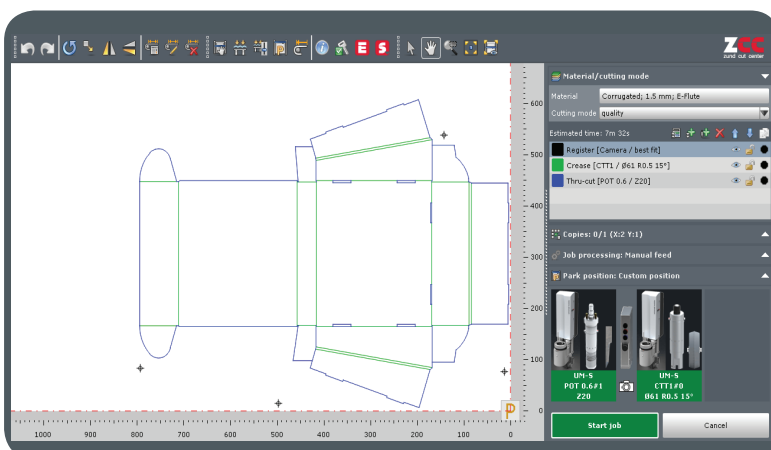

## Cut Center

- Cutting system control center
- Provides tool and blade recommendations
- Select job processes
- Define processing methods



# Innovative solutions meet toughest demands

## Features

- **Zünd Cut Center automatically optimizes cut direction and cut sequence.** To minimize processing time, the software determines the shortest-possible travel distances.
- **Overcut compensation.**
- **Automatic vacuum adjustment** to width of job; vacuum power can be adjusted during processing.
- **Creasing:** downward pressure can be set separately, with and against corrugation.
- **Comprehensive import options.**
- **Simulation before processing** displayed onscreen or performed by cutter with laser pointer.
- **Calculation of estimated production time.**
- **Calculation of travel distances.**
- **Job queue** and complete list of jobs.
- **Email notification** in case of error or required operator intervention.
- **Batch processing** for automated production.
- **Cut-off function** for rolled material or longer boards.
- **Comprehensive registration options** for precise placement of cuts on substrate.
- **Simultaneous job preparation:** While cutter is in operation, additional jobs can be prepared.
- Access to different program functions can be **password protected.**
- **Automated multi-page loading function** with BHS and Sheetfeeder for superior vacuum hold-down.
- **Automatic Bridging:** The number of bridges and minimum distance between them can be specified individually. Bridges effectively keep small cut objects in place and prevent damage to material and bits.
- **Feed connection cut** guarantees consistent cut quality, especially with textiles.
- **Unite operation:** Several overlapping objects may be combined into one.
- **Multiple copies** of objects.
- **Job info export** for generating and analyzing order statistics.

## Routing features

- **Adjust contour offset** for bit size.
- **Inlay function** for routing negative shape into substrate for a perfect fit.
- **Polishing/cleanup pass** for optimal edge quality.
- **Lead-in/lead-out:** Start and end points are positioned outside the cut path for perfect cutting results.
- **Multipass:** The software automatically calculates the optimal number of passes for maximum routing speed while minimizing spindle wear.
- **Tool travel direction clockwise/counter-clockwise.**
- **Dotted line type pattern:** Punching holes can be individually aligned.

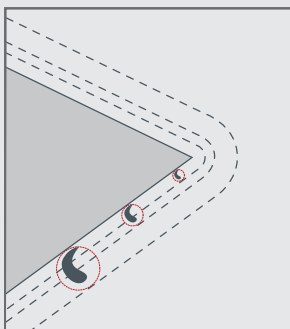

Aligned milling outlines

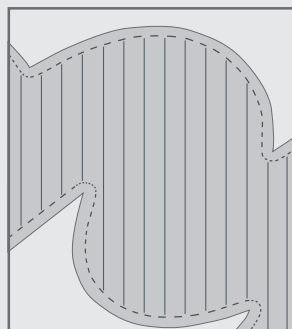

Hatch fill

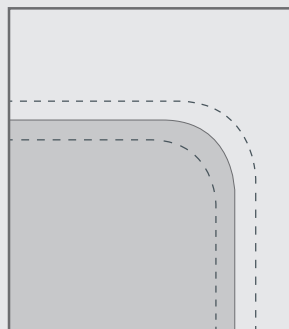

Inlays

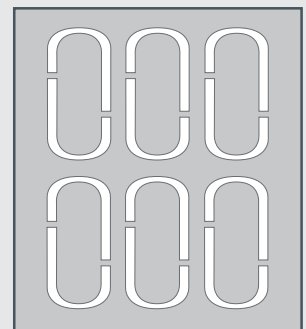

Bridges

**Headquarters**  
**Zünd Systemtechnik AG**  
Industriestrasse 8  
CH-9450 Altstätten  
T +41 71 757 81 00  
F +41 71 757 81 11  
info@zund.com  
www.zund.com

**ZÜND**   
swiss cutting systems