

A woman with blonde hair tied back, wearing a white protective suit with a hood, is leaning over a large, highly reflective surface. Her reflection is clearly visible on the surface. She is looking down at the surface with a focused expression. The background is a plain, light-colored wall.

Meech
MEECH

JetStream

Ionising Air Knife system
for exceptional cleaning performance

Unbeatable performance, unrivalled efficiency

The Meech JetStream ionising air knife system is more than just a piece of equipment. It's a world-beating solution to contamination removal. Capable of being used in a diverse range of applications – both large and small – JetStream's unique technology provides ultimate performance combined with outstanding energy efficiency. Better still, JetStream comes from Meech: a leader in the field, with years of experience gained around the world to give you the perfect solution every time.



Photo courtesy of Dürr AG



We've got the world covered

Wherever you are in the world, you'll find Meech hard at work, providing a wide range of businesses with specialist expertise. From our Headquarters and Technical Centre in the UK, our manufacturing subsidiary in the USA and sales offices in Belgium, Hungary and China, we've got the world covered. In fact, our distribution network now covers 50 countries, providing easy access to fully trained, carefully selected Meech distributors, who can provide in-depth support – wherever you are based.

Outstanding quality as standard

As with every Meech system, quality is at the heart of the JetStream ionising air knife system. We always work to the highest possible quality standards in everything we do: manufacturing, customer support and technical know-how. Our quality management system is certified by BSI to ISO9001. Products manufactured by Meech are also appropriately certified to international standards which include CENELEC EN 60950, UL/CSA (CUL) and CE. We also hold ATEX and UL“EX” approvals for use in hazardous environments. So, you can be sure you've chosen a solution and a company that will meet your own exacting standards.

World leaders in Static Control and Air Technology

No-one knows the specialist fields of static control and air technology better than Meech. The practical benefits can be seen at work in JetStream. Unique design characteristics such as integral ionising bars, deliver important benefits – including enhanced performance and extended lifespan – that help you to maximise the return on your investment.

All the experience you need

Established in 1907, Meech has earned a worldwide reputation for the design and manufacture of effective, durable systems that are supported by our knowledgeable technical team. With so much to offer, no wonder our global user list has grown to in excess of 7,000 companies, including:

- Big Bear Plastic Products Ltd
- Cadence Innovation s.r.o.
- Coors Brewers Ltd
- Ford Motor Company
- Guardian Industries
- Hexcel Composites Ltd
- Honda of the UK Manufacturing Ltd
- IBC Vehicles Ltd
- Nissan Motor Manufacturing (UK) Ltd
- Peguform Iberica S.L.
- Plastic Omnium Varroc PVT Ltd
- RPC Containers Ltd
- Sanyo Electric Group

Technically we're brilliant

Anyone can claim to be a world leader. Meech proves it every day. Our JetStream ionising air knife system incorporates many technically advanced features – including integral ionising bars – that deliver valuable benefits to you.

Better performance

The Meech JetStream ionising air knife system's key advantages include better energy efficiency and cleaning performance. If you want proof, simply compare our solutions to alternatives such as compressed air curtains and nozzles or specialist systems such as ostrich feather units. JetStream wins time after time.

Proven in Practice

Our experience with many different applications means that Meech JetStream ionising air knife systems are used in a wide range of industries throughout the world. So, whatever problem you face, the chances are that we've already solved it.

Energy Efficient

The JetStream system is blower driven and requires dramatically less energy to run than a comparable compressed air system. Energy savings of 70-90% are commonplace.

Ionised Airflow

Why go for ionisation? Quite simply, because an ionised airflow is essential for optimum cleaning performance. Ionised air will break the electrostatic bonds holding contaminants to the surface, enabling effective removal and preventing re-attraction.

Continuous Blade of Ionised Air

With JetStream, you can forget "striping" problems associated with compressed air nozzles. Our solution delivers a balanced, continuous blade of ionised air for totally consistent performance.

High Volume and Pressure of Air

Both high air pressure and high air volume are key factors in cleaning performance. Compressed air systems provide high pressure but insufficient volume to remove contamination efficiently. The JetStream system provides both – without compromise.

Rapid Return on Investment

Although the initial investment in a JetStream system may be higher, the lifetime cost of ownership is substantially lower. Energy savings and productivity improvements deliver a rapid payback (usually much less than 12 months). JetStream systems are also less expensive in terms of both capital and running cost than equivalent ostrich feather systems. This means that, as well as better performance and energy efficiency, JetStream offers outstanding value for money.

Easy Maintenance

The last thing you need is a system that needs constant attention. Unique design characteristics that are built into JetStream greatly simplify maintenance procedures compared to alternative systems. As a result, your productivity is always optimised.





Photo courtesy of Ford Motor Company

Designed to Perform

We've put everything we know about static control and air technology into JetStream. On these pages you'll find just a few of the ways in which our design know-how delivers practical benefits.

Versatile, Tailored Systems

JetStream ionising air knife systems are tailored to meet the specific requirements of each individual customer and application. The range of system components includes:

- Air Knives – overall length from 200mm. Available with Ex (ATEX) rated ionising bar option and either top or end air inlet positions.
- Blowers – energy efficient blowers deliver a high pressure and volume of air. Blower control can be a simple on/off button or an inverter for energy saving and accurate regulation of airflow
- Filtration – as standard, rated to 5 micron.
- Silencing – inlet/outlet blower silencer and acoustic enclosure options to control noise levels to as low as 70dBA.
- Control Panels – Blower, Ionisation and Profiling.

JetStream Air Knife

Conventional Air Knife

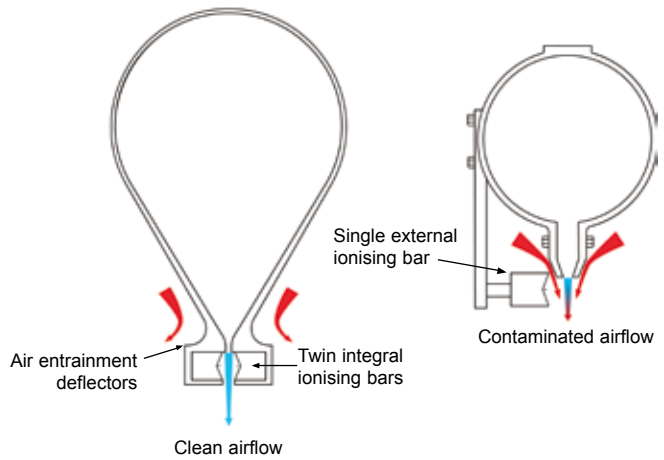

Unique Design Benefits

The JetStream ionising air knife is constructed from hard anodised aluminium and stainless steel, making it suitable for use in most environments. Based on our unrivalled experience, we have included several unique features in the design:

- integral twin ionising bars – provide superior ionisation performance whilst minimising maintenance.
- air entrainment deflectors – minimise the volume of potentially contaminated ambient air that is entrained by the air knife and blown on to the target substrate.
- large plenum – ensures even delivery of the airflow along the length of the air knife.
- inner profile – gives a highly efficient air flow.

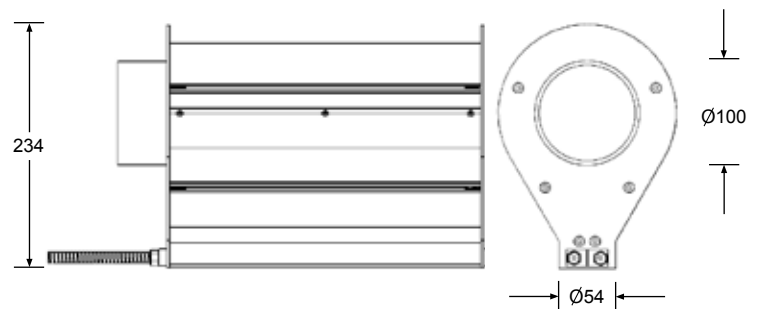
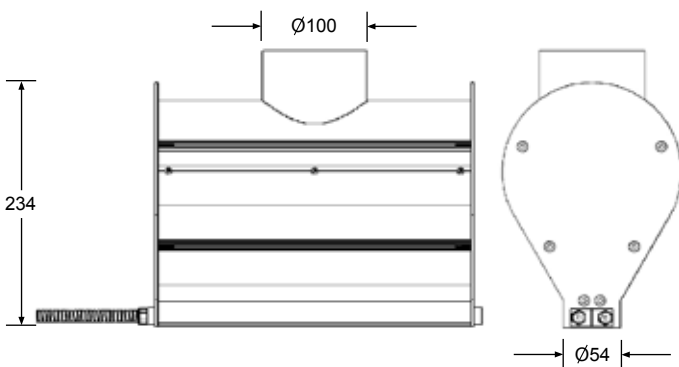

Dimensions in mm

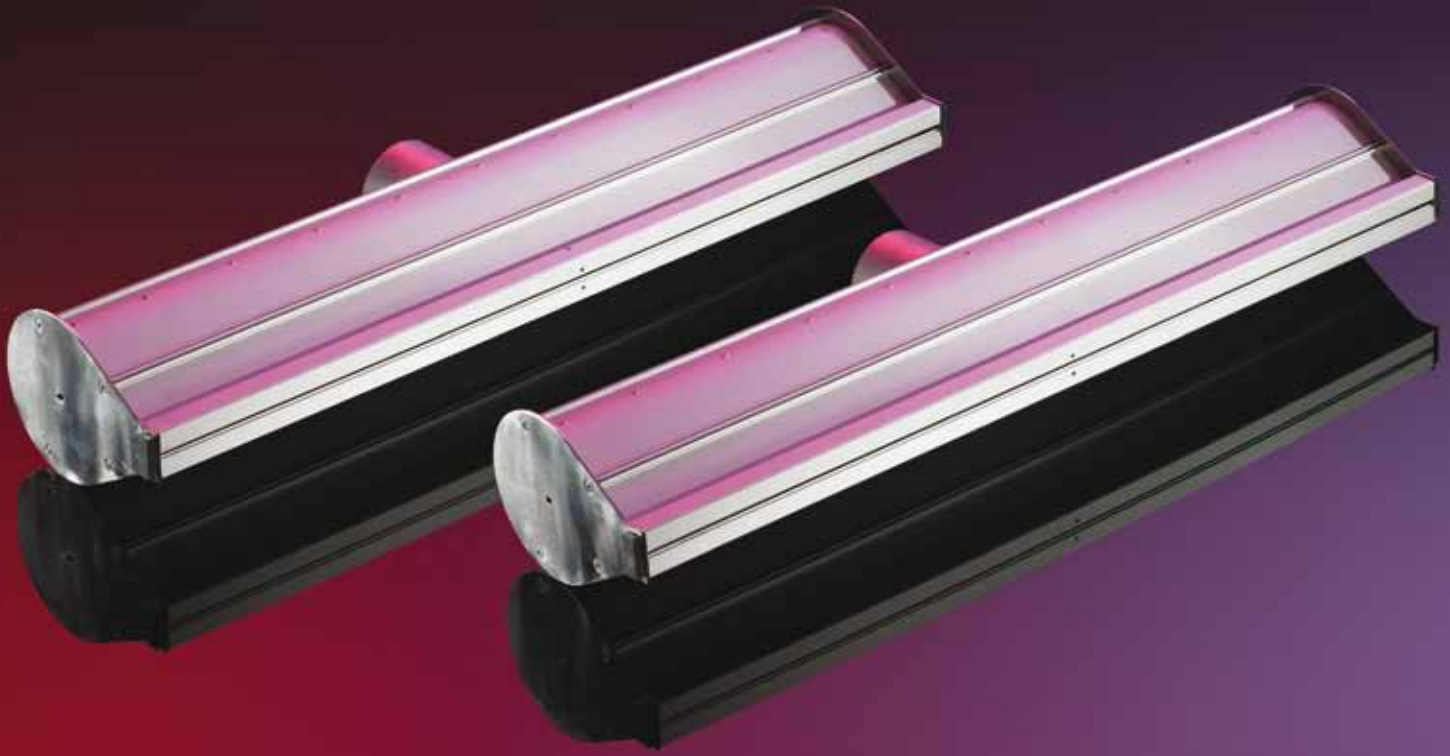

Further System Enhancements

Profiling

JetStream ionising air knife systems are designed to suit each individual application. Three Profiling options are available:

- Fixed – allows manual adjustment of the air knives and is best suited to applications where the part to be cleaned is consistently presented on a jig (e.g. cleaning television cabinet fronts prior to painting).
- Position Profiling – suited to applications where the part to be cleaned is presented consistently but requires more than one surface to be cleaned (e.g. automotive bumpers). The air knives move through a preset number of positions to provide optimum dust removal.
- Real Time Profiling – the air knives move over the total component shape at approximately 100-150mm distance from the surface to provide the best possible static neutralisation and contamination removal. Real time profiling is commonly used on vehicle production lines.

Extraction

JetStream ionising air knife systems can also include extraction to capture contaminants blown from the target surface. Two types of extraction system are available:

- Re-circulating – closed systems that re-circulate the air by blowing and extracting. They include inline filtration and are ideal for applications where maintenance of air flow balance is important (e.g. the automotive industry).
- Non Re-circulating – contaminated air is extracted, filtered and exhausted to atmosphere. Typical applications are where components to be cleaned are presented on a conveyor.

Installation and Commissioning

You're in safe hands with Meech. We offer a full range of installation and commissioning services, including full project management, working alongside your own engineering team and supervising your approved contractors.





Photo courtesy of Honda of the UK Manufacturing Ltd

JetStream in Action

Meech JetStream solutions are trusted across a diverse range of industries and applications. Here are just a few of the sectors where you'll find Meech technology at work around the world every day.

Automotive

Applications are focused on the removal of contaminants (dust, dirt and fibres) to improve paint quality and increase first time pass rates. JetStream ionising air knife systems are used prior to the painting of car, van and truck bodies as well as components such as bumpers, wing mirrors and spoilers.

Beverage/Food Cans

Traditional practice is to clean the insides of cans with sterilising fluid prior to filling. This is energy inefficient, requiring large volumes of fluid to be recycled. Sterile, ionised air from a JetStream system achieves the same result with much greater energy efficiency.

Composite Materials

Dust contamination can be a major issue in the manufacture of composite material structures such as honeycombs. JetStream ionising air knife systems that include an extraction unit enable the highest quality standards to be achieved.

Plastic Parts – Painting

The achievement of high quality levels and low scrap rates require that the surface to be painted is free of contamination and static charge prior to painting. This is easily accomplished with a JetStream ionising air knife system.

Plastic Parts – Printing

Dust contamination can result in poor print quality, high reject levels and frequent line stoppages to clean printing blankets. Installation of a JetStream ionising air knife system enables easy dust removal, leading to improved quality and increased productivity.

Sheet Glass

Cut glass sheets are typically stacked for storage prior to shipping and a powder is applied to the sheet surfaces to allow easy separation. A JetStream ionising air knife system will remove any remaining glass swarf and permit an even application of powder to reduce the risk of surface damage.

... and many, many more



Photo courtesy of Bailey of Bristol

JetStream: Saving time and money

Customer: Big Bear Plastic Products Ltd

From children's slides and sandpits to industrial packaging and caravan panels, Big Bear Plastic Products Ltd is at work 24/7 manufacturing a huge range of products for a wide variety of industries.

Benefit: JetStream ionising air knife systems installed at the Big Bear factory have helped improve quality, productivity and profitability.

Case Study: When Big Bear reviewed their working practices a number of areas were identified where procedures could be made more efficient and the quality of product preparation improved to reduce rejects. One area targeted for improvement was the company's large CNC machine, used to trim two caravan panels simultaneously. Swarf cuttings left by the rotor head were having to be removed manually. This was extremely difficult and time consuming as the cuttings had high levels of static charge. Consequently, as soon as the cuttings were rubbed off the panels, they were attracted again by static.

Meech engineers were called in and advised that two JetStream systems would solve the problem. The JetStream ionising air knife systems neutralised the static charge on the panels and the cuttings simply fell to the floor.

Big Bear were so pleased with the results, they purchased another system to address similar problems they were having with contamination on blank pieces of plastic going into their rotary thermoformer, the largest in Europe. The installation of the JetStream system solved both the quality control and process time problems that the company previously faced.

"Now, thanks to the JetStream systems, contamination is no longer a major quality issue. Installation of the systems has saved the company both time – in terms of less man-hours to complete the processes – and money in terms of no compressed air and fewer rejects."

Works Engineer, Big Bear Plastic Products Ltd



Photo courtesy of Honda of the UK Manufacturing Ltd

JetStream: Driving quality forward

Customer: Honda of the UK Manufacturing Ltd (HUM)

HUM was established on a 370 acre site in Swindon, Wiltshire in 1985. Car production commenced in No 1 Car Plant in 1992 with an annual capacity of 150,000 vehicles. The capacity was expanded to 250,000 cars per year with the opening of No 2 Car Plant in 2001. HUM produces Civic and CR-V models for supply to the markets in the UK, Europe, Middle East, and Africa.

The Plastics Operations Department at HUM moulds and paints plastic car bumpers for both new vehicles and the body repair aftermarket. Every day, approximately 900 bumpers are produced and painted.

Benefit: JetStream ensures high quality bumpers.

Case Study: After arriving from injection moulding, bumpers are covered in particles and other manufacturing deposits left over from the process. To compound the problem, the static charge that is inherent in plastic products causes more dirt to be attracted to the surface. Bumpers need to be thoroughly cleaned and neutralised before undergoing painting.

The Meech JetStream ionising air knife system is installed at the start of the bumper paint procedure to clean and neutralise the bumpers before they undergo the primer application stage. The unique design of the JetStream system ensures that dirt does not re-circulate and re-contaminate painted bumpers.

“Reliability has never been an issue. The JetStream system always runs smoothly and does its job, ensuring our ability to build high quality bumpers.”

Plastics Operations Manager, Honda of the UK Manufacturing Ltd



Photo courtesy of RPC Containers Ltd

JetStream: Boosting productivity

Customer: RPC Containers Ltd

The RPC Group is Europe's leading manufacturer of rigid plastic packaging and is unique in offering products made by all three main conversion processes, blow moulding, injection moulding and thermoforming. The company has over 40 autonomous sites in 12 countries, employing more than 6,500 people.

Benefit: RPC Containers needed to improve productivity on their container print line. A JetStream ionising air knife system helped them surpass their aim.

Case Study: Using injection moulding techniques, RPC Containers in Oakham, UK manufactures open top containers for food and industrial markets. Products include food quality buckets and plastic paint cans and pails for international names such as Histor and ICI Dulux.

Once moulded, the containers are transferred to the print finish line where they are decorated according to each customer's exact specifications. It is here that a JetStream system, housed in an enclosure, has been installed to improve productivity. RPC needed to reduce the frequency with which the line had to be stopped to

clean the printing blanket. Stoppages were occurring as often as 12 times per hour and were caused by dust contamination which meant that the paint would not apply properly to the containers.

JetStream solved the problem immediately. The JetStream system blows a stream of ionised air over the containers, neutralising the static charge and removing contamination from the surface, allowing perfect print finish results. Free from static, the containers no longer attract dust. The contaminated air is then extracted from the enclosure and passed through an inline filtration unit before being re-circulated through the JetStream ionising air knives.

“Results have been dramatic. Since the installation of the JetStream system we have seen a significant drop in the number of times we have to stop the line. It has certainly helped to improve productivity and has made the whole process more efficient.”

Senior Development Engineer, RPC Containers Ltd



Photo courtesy of Jaguar Cars Ltd

JetStream: Creating the perfect finish

Customer: Visteon UK Ltd

Visteon UK Ltd is a Tier 1 automotive supplier, which manufactures consoles, instrument clusters and panels for many of the world's leading automotive companies.

Benefit: To ensure that its painted plastic interior parts are of the highest possible standard, Visteon's robotic paint line has had a Meech JetStream ionising air knife system installed from day one.

Case Study: The robotic paint line at the Visteon factory runs 24/7 and, in order to meet the exacting standards of their customers including prestigious names such as Jaguar and Land Rover, both the quality of the finished product and the efficiency of the line are paramount.

When Visteon were designing and building their paint line, they knew they wanted to use the best possible solutions available at every stage of the process.

The company called in Meech engineers who advised that a JetStream ionising air knife system be installed just inside the paint booth.

As the moulded plastic parts travel along the line, the JetStream system automatically neutralises any static charge and blows off any foreign particles clinging to the surface. This ensures that the interior surface of the component is static free and clear of any dust or fibre contamination before it goes through the robotic spraying process.

“The JetStream system was installed when the paint line was first set up and – as we are working 24/7 – it has proved to be both robust and reliable. It is a vital part of our quality control procedure and is a major contributor in keeping our reject numbers extremely low.”

Paint Facility Engineer, Visteon UK Ltd

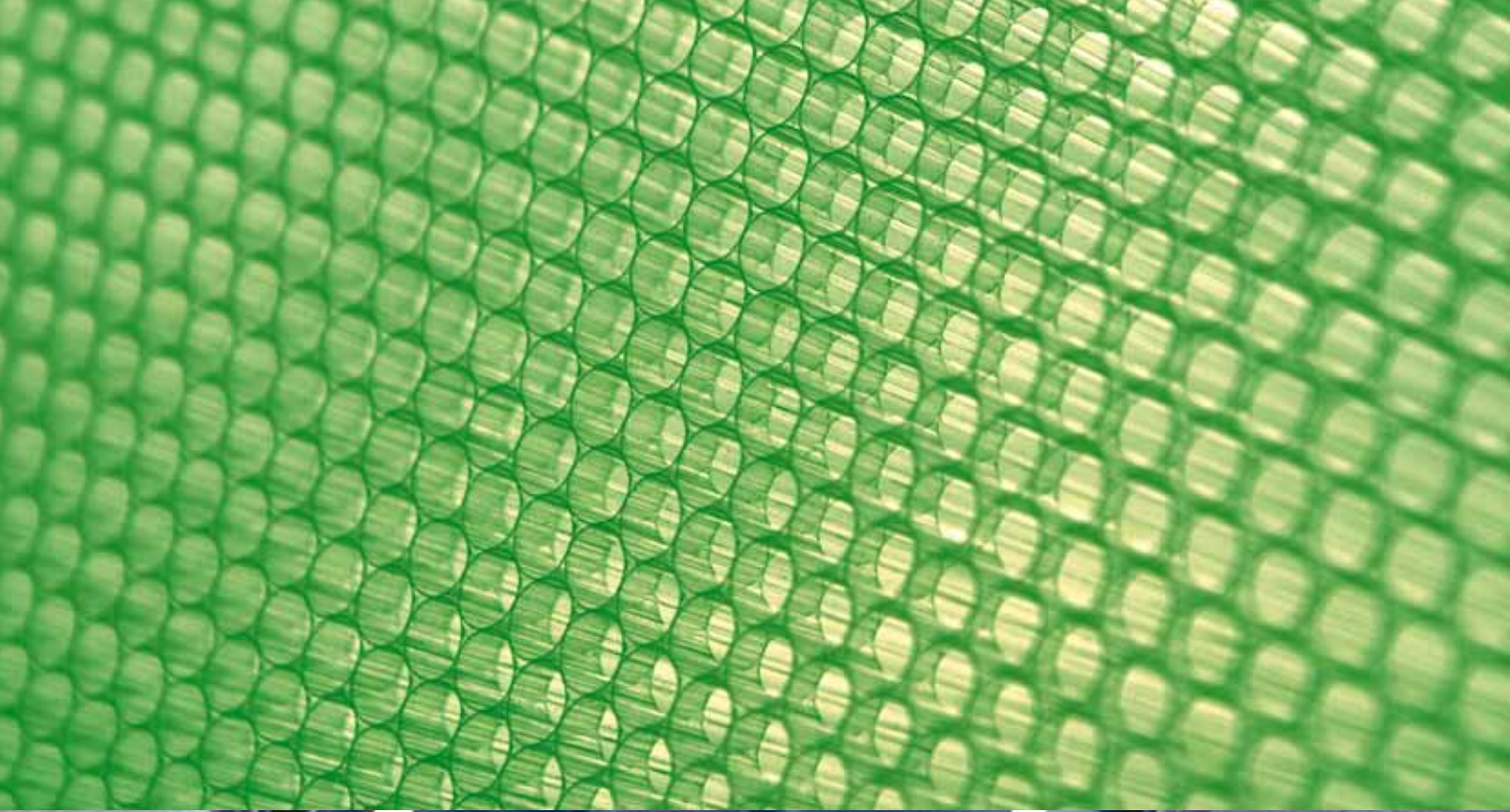

All you need, from the best in the business

Air Knife Drying Systems

Meech also offers energy efficient air knife drying systems that are used to remove surface moisture in amongst others the beverage, fresh produce, plastics extrusion, electronics and automotive industries.

Meech is also a leading provider of:

- **Industrial Static Control Systems** – Eliminating unwanted static or creating a controlled static charge in industrial processes can increase productivity, reduce waste and enhance quality.
- **Web Cleaning Systems** – Typically used within the printing and packaging industries to remove contamination, improve print quality and increase productivity.
- **Air Technology Equipment** – Compressed air products that save energy, reduce noise levels and provide efficient cooling.
- **ESD** – High sensitivity static control for electronic cleanroom environments to prevent ESD damage and reduce failure rates.





Meech International

2 Network Point
Range Road, Witney
Oxfordshire
OX29 0YN
UK

Tel: +44 (0) 1993 706700
Fax: +44 (0) 1993 776977
e-mail: sales@meech.com

Meech Static Eliminators USA Inc

2915 Newpark Drive
Norton OH 44203
USA

Tel: +1 330 564 2000 / 1 800 232 4210
Fax: +1 330 564 2005
e-mail: info@meech.com

Meech Elektrostatik SA

Av C Grandprez 27
B 4970, Stavelot
Belgium

Tel: +32 8086 2983
Fax: +32 8086 2821
e-mail: mesa@meech.com

Meech CE

2151 Fót
Széchenyiút. 46
Hungary

Tel: +36 27535075
Fax: +36 27535076
e-mail: ce@meech.com

Meech China

Room 205, Huana Hotel Office Tower
No. 1733 Lianhua Road
Shanghai 201103
China PR

Tel: + 86 21 6119 6723/ 6119 6724
Fax: + 86 21 6119 6725
Mobile: 01380169 2517

email: china@meech.com