

JERRYCAN 30 DTN

30 litres jerrycan, 2 bungs, 1 handle on the top

- Jerrycan in high-density polyethylene produced by blow moulding.
- Storage, handling and transportation of products in liquid and viscous form manufactured by the chemical, petro-chemical and food industries (FDA).
- Easy handling thanks to a handle on the top.
- Optimal drainage thanks to two grips at the bottom of the jerrycan.



APPROVALS

- Transportation of dangerous liquid goods with densities of less than or equal to 1.9 (Group II).
- In accordance with UN recommendations, with derived modal regulations (RID/ADR, IATA, IMDG Code).

NOTES

- Jerrycan in PEHD resistant to most chemical substances. If you have a doubt, ask us for advice.
- Light, odourless and suitable for use as packaging for food products.
- Does not age or corrode.
- Can be customised by means of labelling or a printed polyethylene sleeve.
- Easy to stack and palletise and is recyclable.

AVERAGE DIMENSIONS

30 DTN		30 L
H height	± 5 mm	520 mm
h height	± 3 mm	97 mm
ø C	± 4 mm	302 mm
ø O 1 (diameter, BCS 56 x 4)	mm	53 mm
ø O 2 (diameter, BCS 24 x 4)	mm	19,5 mm
D decoration area height	± 3 mm	324 mm
Mass without bung	± 3% kg	1,15 kg
Total overflow capacity	± 1L	32,5 L
Maximum recommended stacking of jerrycans for substances with densities of 1.2 à 20 °C		1+2

TRANSPORTATION

30 DTN	
Pallet dimension (mm)	1140 x 1140
Nb. jerrycans per layer	16
Nb. layers per pallet	4
Nb. jerrycans per pallet	64
Nb. pallets per full lorry	26
Nb. jerrycans per full lorry	1664
Height of palletisation (mm)	2215

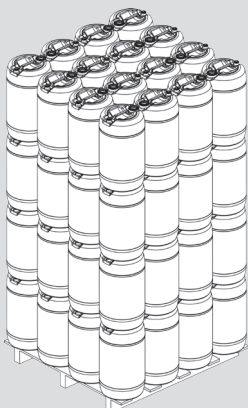

Palettisation per 64

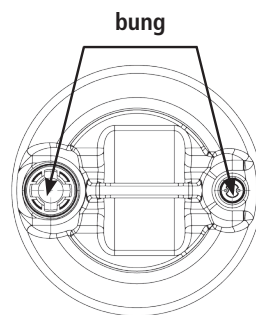
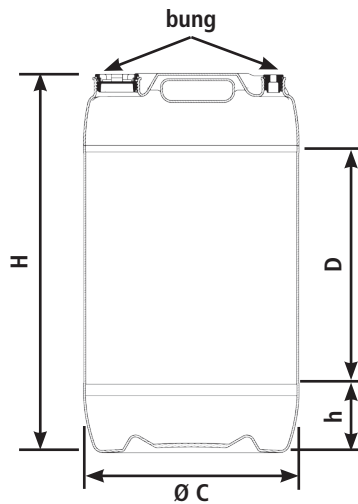

BUNG

RECOMMENDED TIGHTENING TORQUES

2" Bung : 12/15 Nm

3/4" Bung : 10/12 Nm

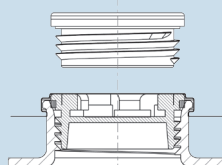

EQUIPMENT

- Integrated handle on the top.
- 2 grips at the bottom of the jerrycan, in the axis of the bung.
- 2 bungs BCS 56 x 4 and 24 x 4.
- Centring pins for stacking.
- Various adaptations (taps, degassing valve, over-stopper, etc.): ask for details.

COLOUR

- Jerrycan: blue.



SOTRALENTZ
PACKAGING

INSTRUCTIONS FOR USE OF JERRYCANS AND DRUMS IN POLYETHYLENE (PEHD)

HOW SHOULD YOU CHOOSE A JERRYCAN OR A DRUM?

• Depending on the nature of the substance you are packaging, on its method of storage, handling, transportation and end use, Sotralentz Emballage will provide you with advice to enable you to choose the jerrycan or the drum to perfectly suit your needs.

• Compatibility with the contents is the responsibility of the user which fills a container. The user absolutely must ensure that the contents are compatible with the packaging material, with its closing systems, and with its joints.

• The density of the substance being packaged determines the height of stacking allowed and also the handling methods which need to be employed.

The density affects the weight of the jerrycan or drum to be used in calculations. If the density is high, particularly if it is 1.3 or higher, you must be very careful as regards calculations of the stacking height.

1. STORAGE.

• Absolutely do not store goods near to sources of heat (hot pipes, hot tanks, radiators, etc., etc.) or sparks.

• Do not store a jerrycan or drum in dirty or contaminated areas.

• Avoid prolonged storage of a jerrycan or a drum outdoors, entailing direct exposure to ultraviolet rays (U.V. light).

2. FILLING.

• Ensure that the pipe or the filling system is not in danger of damaging the packaging and in particular the closing area.

• The tightening torque used on the plugs must be that specified by the packaging manufacturer and the recommended torque must not be exceeded.

• Should a plug with a vent be used: plugs with a vent must under no circumstances be re-used.

3. FILLING JERRYCANS AND DRUMS WITH A SUBSTANCE WHICH IS HOT.

• Do not stack jerrycans or drums made from PEHD while they are still warm.

• A temperature of 80°C may be attained for a short period (a few hours) subsequent to filling, without damage being caused to the shape of the jerrycan or drum. As regards longer periods, do not exceed 60°C.

• Compatibility of the contents must also be checked should the usage temperature be high. Certain chemical substances can prove to be incompatible with high-density polyethylene (PEHD) at temperatures of above 25°C.

• When filling with hot substances is being carried out, the jerrycan or drum must be positioned on a flat surface. Floors and surfaces with openings and light or unsuitable pallets should absolutely not be used.

• After being filled with a hot substance, the jerrycan or drum should be left open until the contents have cooled down and reached the ambient temperature in the filling area, or be equipped with a plug with a venting device.

4. HANDLING, STORAGE AND TRANSPORTATION OF FULL JERRYCANS AND DRUMS.

• Use a lifting device which is suitable in relation for the handling of the jerrycan or drum. If you are in doubt please ask us for advice.

• Use pallets which are in a good condition, of a size which is suitable as regards the jerrycan or drum and preferably which have a full (or complete) top surface. Check that the pallets have no broken areas, splinters, nails or parts jutting out which could pierce the jerrycan or drum. Do not palletise with the jerrycan or drum sticking out over the side of the pallet.

• Only stack on flat ground which can bear the load.

• As regards jerrycans or drums equipped with a venting system, they absolutely must be stored in an upright position.

• Ensure that the end user does indeed have all of the information regarding stacking conditions and in particular regarding the recommended maximum stacking height.

• Regarding piling (stacking) on a pallet, all of the jerrycans or drums have to be of the same model and have the same dimensions. Never pile jerrycans or drums with different shapes or sizes or of different types on top of each other.

• Ensure that the method on wrapping film around or of covering, whether it be stretched or drawn in, is capable of securing together all of the load on the pallet and that there is no risk that the jerrycans or drums will be forced out of shape by too strong a force. Concerning a jerrycan or a drum with a low weight, it is preferable to use protective angle sections made from cardboard or plastic.

5. MARKING AND DANGEROUS GOODS APPROVALS.

• The UN (United Nations) mark certifies that the jerrycan or drum complies with the recommendations of the UN in respect of the transportation of dangerous goods and with the derived regulations for various forms of transportation (RID/ADR, IATA, the IMDG Code).

• The level of approval (regarding density, packaging group, hydraulic pressure) set out in the UN marking represents the level of performance for products which are chemically comparable to water. As regards other standard liquids, the level of performance is generally lower. Please refer to the approval certificates.

• The stacking trial carried out for the approval is undertaken in a "guided" loading manner and deformation of the packaging which is being tested is acceptable. The value of the load applied during the course of the trial can therefore only be used in practice for static stacking but less so for dynamic stacking. Please refer to the recommendations detailed on the specifications sheets for the packaging.

• The value of the hydraulic pressure indicated in the UN marking is equivalent to the pressure at which the packaging resists over a maximum period of 30 minutes. This hydraulic pressure value must not be used as a reference value in respect of container unpacking carried out by the push back method.

• The nominal capacity of the jerrycan or of the drum must be regarded as an approximate value.

SOTRALENTZ PACKAGING ALSO OFFERS:



Jerrycans



Barrels with bungs



Open top drums



IBC Containers

Find the whole range of
SOTRALENTZ Packaging products
at www.sotralentz.com

SOTRALENTZ PACKAGING S.A.S - B.P. 10028 - F-67320 DRULINGEN - www.sotralentz.com
Tel. +33 (0)3 88 01 68 00 - Fax +33 (0)3 88 01 68 02 - E-mail : emballage@sotralentz.com

SOTRALENTZ RECYCLING SERVICE - Tél. +33 (0)3 88 01 68 29 - Fax. +33 (0)3 88 01 68 06

This sheet is intended for information purposes only. SOTRALENTZ reserves the right for any deviations or changes on its products.



SOTRALENTZ
PACKAGING