

Tenue de soirée

Collection 2014 by  FIRPLAST



La gamme du bon goût

Des idées ...

 **FIRPLAST**
pour vous « emballer »

30 ans

CATLUX06

PACK POUR LE FUTUR

Edito

Dear Valued Customers,

For the past 30 years, Firplast has been catering to all of your catering needs with fresh, innovative ideas.

We are proud to provide you with more solutions that will transport you to new creative heights each and every day!

After introducing our new on-line ordering system, with its personalized profiles, and welcoming both the mes-verrines.com site and “La Vaiselle d’Eugénie [Eugenie’s Tableware]” (p.73) into our company, today we are happy to present our exciting catalogue for 2014: Tenue de Soirée [Putting on the Ritz]!

Because Firplast cares about protecting the environment, we are offering a full range of ecological and completely biodegradable products in this year’s catalogue (p.20). Look for the Ladybird symbol to find our Vision Verte [Seeing Green] range and help make a bright future with Firplast!

Discover the latest collections created especially for you by our great team of designers! From the pure lines of our very complete Esmeralda range (p.10) to the gastronomical tradition of our “Frenchy folies” [Flight of French Fancy] range (p.12), you will find the products you need to create the presentations of your dreams.

Our transportation solutions and our adaptable tray systems are even more original and enticing [p.22], of course.

And, don’t forget that our team is always ready to help you with every aspect of your packaging needs, from the early planning stages to adding the personalized touches that give your projects that special polish!

The Team 

Queridos clientes,

Firplast cumple 30 años dedicados al desarrollo de ideas de packaging atractivas.

Nos sentimos orgullosos de poder ofrecerles nuevas soluciones para ayudarles en el día a día.

Tras la puesta en funcionamiento de nuestra nueva página web de compra en línea –donde podrán disponer de un espacio de cliente personalizado– y la incorporación a nuestro grupo de las páginas web mes-verrines.com y La Vaiselle d’Eugénie (p.73), le presentamos la edición 2014 de nuestro catálogo «Tenue de Soirée».

En Firplast somos conscientes de la actual preocupación sobre la protección del medioambiente y, por ello, les ofrecemos una gama eco-responsable completamente biodegradable (p.20). En esta edición, todos los productos en los que figura una mariquita forman parte de nuestra línea ecológica «Vision Verte». Por un futuro mejor.

Les invitamos a descubrir las nuevas colecciones que nuestros diseñadores han creado para ustedes. Desde la pureza de líneas de la completa gama «Esmeralda» (p.10) al respeto por la tradición gastronómica en la serie «frenchy folies» (p.12), déjense llevar por la imaginación, nuestros productos les satisfarán.

Además, disponemos de soluciones para el transporte y para eventos que requieran rapidez y dinamismo con nuestras originales y atractivas bandejas para comida (p.22).

Y recuerde que, desde el diseño a la personalización, nuestro departamento de comunicación está siempre a su servicio para ayudarles a desarrollar sus proyectos de packaging.

El equipo 

Conception, fabrication & distribution

FIRPLAST LYON SERVICE COMMERCIAL

4 rue de Provence · 69800 SAINT PRIEST
Tél : 04 72 23 66 66 · Fax : 04 78 20 54 40
Mail : contact@firplast.com
www.firplast.com

Créé en 1983, Firplast est en mesure de vous proposer un service efficace et adapté grâce à ses structures, ses capacités techniques et ses moyens humains. Nous vous permettons à l'aide d'un franco étudié de gérer au mieux vos flux sans augmenter votre coût de stockage.

- Plus de 100 000 m³ de surface de stockage.
- Tous les articles présents dans le catalogue sont en stock.
- Procédure rapide de traitement des commandes jour A (par téléphone, fax, mail).
- Expédition des commandes jour B.
- Livraison par nos camions ou messagerie sous 48 à 72 h pour la France métropolitaine et sous 10 jours pour les autres pays européens.

Nous livrons le monde entier, n'hésitez pas à contacter notre responsable export pour toute question : export@firplast.com

Nos autres missions :

- **Solutions durables** et respectueuses de l'environnement pour particuliers et professionnels : contact@vision-verte.com
- **Conditionnement** adapté aux particuliers et à la grande distribution : contact@mes-verrines.com
- **Décoration à thème**, animation, et déguisements : contact@axho.com
- **Liaison froide et collectivités** : collectivite@firplast.com
- **Solutions transport** : nomade@firplast.com

N'hésitez pas à vous rendre sur nos sites internet ou nous contactez. Notre service commercial prendra contact avec vous dans les meilleurs délais.

Découvrez tout notre univers sur nos sites et retrouvez la version PDF de notre catalogue sur : www.firplast.com/catalogues



crédit image :
Mappy



Notre réseau dans le monde

We deliver worldwide. Please contact our Export Manager for further information: export@firplast.com

Our other missions:

- **Sustainable solutions** that respect the environment, for end-customers and professionals: contact@vision-verte.com
- **Packaging** suitable for use by end-customers and large retailers : contact@mes-verrines.com
- **Themed decorations**, entertainment and fancy dress: contact@axho.com
- **Winter season community outreach and liaison**: collectivite@firplast.com
- **Transportation solutions**: nomade@firplast.com

Hacemos envíos a cualquier lugar del mundo. Si desea realizar alguna consulta, no dude en ponerse en contacto con nuestro departamento de exportaciones: export@firplast.com

Otros departamentos:

- **Soluciones sostenibles** y respetuosas con el medioambiente para particulares y profesionales: contact@vision-verte.com
- **Embalajes** para particulares y grandes empresas de distribución: contact@mes-verrines.com
- **Decoración temática**, actividades y disfraces: contact@axho.com
- **Línea fría y colectividades**: collectivite@firplast.com
- **Soluciones de transporte**: nomade@firplast.com

We invite you to visit our websites or to contact us directly. Our sales department will respond to your queries without delay.

Discover the whole range of our products and services on-line and download our catalogue in PDF format at: www.firplast.com/catalogues

No dude en visitar nuestras páginas web o en ponerse en contacto con nosotros. Nuestro departamento de ventas se pondrá en contacto con usted lo antes posible. Consulte todos nuestros productos en nuestras páginas web y la versión PDF de nuestro catálogo en : www.firplast.com/catalogues



www.firplast.com



www.mes-verrines.com



Mes-verrines.com

www.vision-verte.com



www.axho.com



Sommaire

COLLECTIONS 2014



• «ESMERALDA»

• «FRENCHY FOLIES»

• «O'RONDE»

• «NECT'ART»

• «WOOD MOOD»

• «VISION VERTE»

• «NON STOP»

VERRINES «UNIVERSES»

• LES VERRINES

• LA PRÉSENTATION ET LE TRANSPORT

PLATEAUX REPAS

ASSIETTES

SALADIERS ET MINI-POTS

COUPES DESSERTS

COUVERTS, SACHETS COUVERTS ET ACCESSOIRES

VERRES

SERVIETTES ET NAPPES

SOLUTIONS TRANSPORT

INFORMATIONS TECHNIQUES MATIÈRES

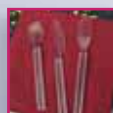

Contents

Sumario

.....COLLECTIONS 2014	COLLECTIONS 2014.....	P. 8 - 23
.....«ESMERALDA»	«ESMERALDA»	P. 10 - 11
.....«FRENCHY FOLIES»	«FRENCHY FOLIES».....	P. 12 - 13
.....«O'RONDE»	«O'RONDE»	P. 14 - 15
.....«NECT'ART»	«NECT'ART»	P. 16 - 17
.....«WOOD MOOD»	«WOOD MOOD»	P. 18 - 19
.....«VISION VERTE»	«VISION VERTE»	P. 20 - 21
.....«NON STOP»	«NON STOP»	P. 22 - 23
.....«UNIVERSES» VERRINES.....	RECIPIENTES «UNIVERSES»	P. 26 - 59
..... VERRINES	LOS RECIPIENTES	P. 26 - 54
..... PRESENTATION AND TRANSPORTATION/LA PRESENTACIÓN Y EL TRANSPORTE .		P. 55 - 59
..... MEAL TRAYS	BANDEJAS PARA COMIDA	P. 60 - 93
..... PLATES.....	PLATOS.....	P. 94 - 104
..... SALAD BOWLS AND MINI-CUPS.....	ENSALADERAS Y TARRITOS	P. 105 - 110
..... DESSERT DISHES	COPAS PARA POSTRE	P. 111 - 112
..... CUTLERY AND ACCESSORIES / CUBIERTOS,BOLSAS PARA CUBIERTOS Y ACCESORIOS		P. 113 - 122
..... GLASSES	VASOS	P. 123 - 126
..... TABLE LINENS	SERVILLETAS Y MANTELES.....	P. 127 - 133
..... TRANSPORTATION	TRANSPORTE.....	P. 134 - 141
..... TECHNICAL INFORMATION.....	INFORMACIÓN TÉCNICA, MATERIALES ..	P. 144

Pour ses 30 ans, FIRPLAST Crée la surprise et lance ses nouvelles collections afin d'offrir des solutions adaptées à tous les défis de notre temps.

Tradition, modernité, praticité, fonctionnalité, respect de l'environnement, originalité, transport, rangement...

Pour certains juste des promesses, pour nous un enjeu. Mais trêve de blabla, découvrez tout ça par vous même dans les pages qui suivent...

Collection « Esmeralda »

page 10 - 11



Collection « Frenchy folies »

page 12 - 13



Collection «O'Ronde»

page 14 - 15



Collection «Nect'Art»

page 16 - 17



Collection «Wood mood»

page 18 - 19



Collection «Non Stop»

page 22 - 23



Collection «Vision Verte»

page 20 - 21

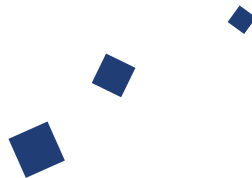



Collection « Esmeralda »



Des idées ...
FIRPLAST Collection 2014
pour « emballer »



Couverts «GIVRÉS»
«GIVRÉS» Cutlery
Cubiertos «GIVRÉS»
Voir page 115



Serviette
Serviette
Servilleta
Voir page 129

- Une ligne épurée, une courbe parfaite, une géométrie complexe ? Ne cherchez plus, la gamme Esméralda répond à toutes vos attentes. Originalité, modularité, élégance des formes, transparence pour une plus grande visibilité de vos préparations. Vous ne rêvez pas, Esméralda est là !



Flûte «CHAMPAGNE»
«CHAMPAGNE» Flute
Copa «CHAMPAGNE»
Voir page 123



Cuillère «TAPAS»
«TAPAS» Spoon
Cuchara «TAPAS»
Voir page 27



Plateau «LUXE»
«LUXE» Tray
Bandeja «LUXE»
Voir page 68



Boîte de transport
avec calage pour 24 verrines
Transport Box
with insert for 24 glasses
Caja de transporte
con troquelado para 24
vasitos
Voir page 139



Verrine «SAINT TROPEZ»
«SAINT TROPEZ» Verrine
Vasito «SAINT TROPEZ»
Voir page 36



Cuillère «MONACO»
«MONACO» Spoon
Cuchara «MONACO»



Variez les plaisirs !
Existe aussi en noir et en blanc
Voir page 27



Assiette et Plateau repas «JADE» avec couvercle
«JADE» Plate and Transport box with lid
Plato y bandeja con tapa «JADE»
Voir page 95



Verrine «VENISE»
«VENISE» Verrine
Vaso «VENISE»
Voir page 26



Collection «Frenchy folies»



Couverts «INOX»
«STAINLESS» Cutlery
Cubiertos «INOX»
Voir page 113



Cocotte ovale
Oval Casserole
Cazuela ovaladair
Voir page 34



Verre à vin
Wine Glass
Copa de vino
Voir page 123

- Qui a dit que dans ce monde à 200 à l'heure toutes les valeurs se perdaient ? Renouez avec la tradition grâce à la toute nouvelle collection Frenchy folies ! Des formes connues et reconnues dans des matériaux différents ! Une gamme qui saura séduire les amoureux du temps jadis comme ceux qui rêvent d'avenir !



Caisse de transport
Transport Case
Caja de transporte
Voir page 135



Boîte «BENTO»
«BENTO» Box
Caja «BENTO»
Voir page 64



Serviette «VOIE SÈCHE»
«VOIE SÈCHE»
Absorbent Serviette
Servilleta «VOIE SÈCHE»
Voir page 129



Nappage «VOIE SÈCHE»
«VOIE SÈCHE» Absorbent Tablecloth
Mantel «VOIE SÈCHE»
Voir page 133

Plateau «LUXE»
«LUXE» Tray
Bandeja «LUXE»
Voir page 68



Assiette «ROC» SIMILI ARDOISE
«ROC» Imitation Slate Plate
Plato «ROC» imitaciòn pizarra
Retrouvez toute la gamme page 55



Bocaux «TERROIR»
4,5 cl / 8 cl / 30 cl
«TERROIR» Jar
Tarro «TERROIR»
Voir page 30



Collection «O'Ronde»



Sphère «DOUBLE FOND» 4 cl
«DOUBLE FOND» Sphere 4 cl
ESFERA «DOUBLE FOND» 4 CL
Voir page 37

- La Terre est ronde, qu'on se le dise. Si une forme se prête bien aux cuisines actuelles et à la créativité débordante des plus grands chefs, c'est bien la sphère. Avec la collection O' Ronde, imaginez la cuisine de demain ! Existe en 2 matières : PS et verre



Verrine «SPHÈRE» 22 cl
«SPHÈRE» Verrine 22 cl
Vasito «SPHÈRE» 22 cl
Voir page 37



Couverts «COCKTAIL» argent
«COCKTAIL» Silver Cutlery
Cubiertos «COCKTAIL» plateados
Voir page 115

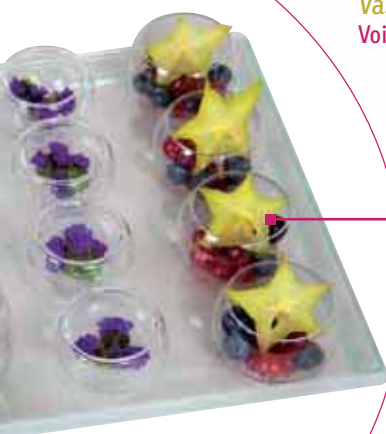

Plateau «LUXE»
«LUXE» Tray
Bandeja «LUXE»
Voir page 68



Verrine «SPHÈRE» 20 cl
«SPHÈRE» Verrine 20 cl
Vasito «SPHÈRE» 20 cl
Voir page 36

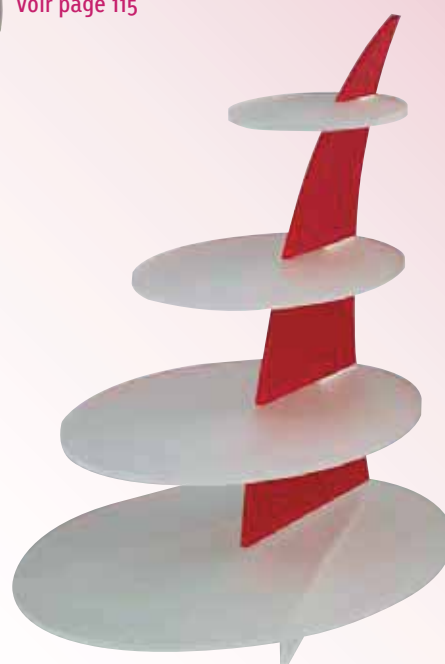

Présentoir «SQUALE»
«SQUALE» Serving Stand
Expositor «SQUALE»
Voir page 56



Verrine «SPHÈRE» 19,5 cl
«SPHÈRE» Verrine 19,5 cl
Vasito «SPHÈRE» 19,5 cl
Voir page 37



Verrine «SAINT TROPEZ»
«SAINT TROPEZ» Verrine
Vasito «SAINT TROPEZ»
Voir page 36



Verrine «SPHÈRE» 15 cl
«SPHERE» Verrine 15 cl
Vasito «SPHÈRE» 15 cl
Voir page 36



Collection

«Nect Art»



Verre «CRISTAL»
octogonal
'CRISTAL' Octagonal Glass
Vaso cristal
Voir page 124



Verre
«LONG DRINK»
'LONG DRINK' Glass
Vaso long drink
Voir page 123



Tasse «CAFÉ»
'CAFÉ' Coffee Cup
Taza de café
Voir page 124
Spatule «CAFÉ» bois
'CAFÉ' Wooden Coffee Stirrer
Paletina de madera
Voir page 121

- Encore une petite goutte ? Une pause café ? Une larme de whisky, un doigt pas plus, une mesure de cointreau, le nectar des nectars, l'or bleu... Il ne nous en a pas fallu plus pour comprendre l'importance de dédicacer une collection entière aux liquides et leurs contenants : Firplast à l'honneur de vous présenter la collection «Nect arT».



Verre «COCKTAIL»
«COCKTAIL» Glass
Copa «COCKTAIL»
Voir page 123

Agitateur multicolore
Coloured Swizzle Stick
Removedor multicolor
Voir page 121



Flûte «CHAMPAGNE»
«CHAMPAGNE» Flute
Copa «CHAMPAGNE»
Voir page 123

Flûte «CRISTAL» 15 cl
«CRISTAL» Flute 15 cl
COPA «CRISTAL» 15 CL
Voir page 124



Plateau présentation
pour 20 verres/flûtes
Display Tray for 20 glasses
Bandeja para 20
Voir page 124

Verre «VIN»
«WINE» Glass
Copa «VIN»
Voir page 123



Assiette «COCKTAIL» avec
emplacement verre/flûte
«COCKTAIL» Plate with Glass Holder
Plato «COCKTAIL» con
Voir page 104



Cuillère «COCKTAIL» argent
«COCKTAIL» Silver Dessert Spoon
Cuchara «COCKTAIL»
Voir page 115



Mini bol (existe aussi en rose et en vert)
Mini Bowl (also available in pink and green)
Minibol (también en rosa y en verde)
Voir page 38

Plateau «LUXE»
«LUXE» Tray
Bandeja «LUXE»
Voir page 68





Collection



«Wood mood»



Ramequin «SOLO» rond
«SOLO» Round Ramekin
Ramequín redondo «SOLO»
Voir page 43

Cuillère «GOUTTE D'EAU»
«GOUTTE D'EAU» Spoon
Cuchara «GOUTTE D'EAU»
Voir page 44



Pic sur pied
Pick with Stand
Pincho con base
Voir page 119

Pique noeud et
Pique drapeau
Bow stick and flag stick
Pincho con nudo y pincho
con extremo plano
Voir page 119



Fourchette
et cuillère
Spoon and Fork
Tenedor y cuchara
Voir page 119

Ramequin «TRIO» rond
«TRIO» Round Ramekin
Ramequín redondo «TRIO»
Voir page 43

Assiette bois «RONDE»
«RONDE» Wooden Plate
Plato de madera «RONDE»
Voir page 100



Ramequin «DUO ROND»
«DUO ROUND» Ramekin
Ramequín redondo «DUO»
Voir page 43



Petite barquette
Small serving boat - Cesta pequeña
Voir page 42

- Saviez vous que depuis des millénaires, toute l'Asie utilise le Bambou car il pousse très rapidement (jusqu'à 1 mètre par jour !) et que son impact sur les ressources naturelles est moindre. Et dire que les Pandas en raffolent...

Coupelle ronde
Small round dish
Fuentecita redonda
 Voir page 43



Couverts bois
Wooden Cutlery
Cubiertos bebo
 Voir page 117



- Si vous êtes plutôt d'humeur bois traditionnels, le peuplier et le pin sont faits pour vous.

Dans tout les cas, avec la collection Wood Mood, c'est l'esprit naturel qui l'emporte et vos créations auront une saveur de nature...



Attention, voici la coccinelle. Produits biodégradables et compostables !!



Moyenne barquette
Medium serving boat
Cesta mediana
 Voir page 42



Grande barquette
Large serving boat
Cesta grande
 Voir page 42

Assiette bois «RECTANGLE»
 «RECTANGLE» *Wooden Plate*
 Plato de madera «RECTANGLE»
 Voir page 100



Collection



«*Vision verte*»



Couverts PLA
Cubiertos PLA
Cubiertos «PLA»
Voir page 117



Verrine «RONDE»
«RONDE» Verrine - Plato «RONDE»
Voir page 45

La nature va vers la simplicité. Voici enfin une gamme complète réalisée à base de pulpe de canne à sucre qui saura ravir votre créativité. Simplicité, originalité et touché inégalé garantissent aux sens un ravissement sans précédent !! Pensez Bio !



Étanches aux graisses, micro-ondables, elles résistent à l'eau et à l'huile jusqu'à 100 °C. Nous vous proposons toute une gamme de couvercles pour nos assiettes, plateaux repas et saladiers.

Produit personnalisable +++

Et pour plus de solutions écologiques, n'hésitez pas à consulter notre catalogue «Vision Verte» ou le site www.vision-verte.com.

Serviette «ÉCOLOGIQUE»
«ÉCOLOGIQUE» Serviette
Servilleta «ÉCOLOGIQUE»
Voir page 129



Gobelet 26 cl
Tumbler 26 cl
Vaso 26 cl
Voir page 109



Plateau Pulpe
Cellulose tray
Bandeja de pulpa prensada
Voir page 78



Pot 14 cl
Cup 14 cl
Bote 14 cl
Voir page 109



Verrine «1/2 OEUF»
'1/2 OEUF' Verrine
Vasito «1/2 huevo»
Voir page 45



Assiette «CARRÉE»
avec emplacement verre
«CARRÉE» Plate with Glass Holder
PLATO «CARRÉE» CON PORTAVASOS
Voir page 104



Verrine «CARRÉE»
«CARRÉE» Verrine
Plato «CARRÉE»
Voir page 45



Assiette «RECTANGLE»
«RECTANGLE» Plate - Plato «RECTANGLE»
Voir page 102



Collection

«Non Stop»



Plateau «VAGUE»
'VAGUE' Tray
Bandeja «VAGUE»
Voir page 72



BOCAUX «TERROIR»
'TERROIR' Jar
Tarro «TERROIR»
Voir page 30



Plateau «LUXE»
«LUXE» Tray
Bandeja «LUXE»
Voir page 68



Plateau «BENTO»
«BENTO» Tray
Bandeja «BENTO»
Voir page 64



Plateau «TOKUDAÏ»
«TOKUDAÏ» Tray
Bandeja «TOKUDAÏ»
Voir page 83

- Réalisez vos créations culinaires en accord avec le contenant, c'est possible avec notre gamme Non Stop ! Des solutions de présentation, des solutions de livraison, des solutions pour le conditionnement, des solutions, des solutions et surtout des solutions !

Du choix, de l'originalité et de la modularité. Voici le cahier des charges que nous nous sommes fixés pour répondre à vos besoins. Cette collection enchantera traiteurs et collectivités pour sa fonctionnalité et son design !



Plateau «FAMOUS BREAK»
«FAMOUS BREAK» tray
Bandeja «FAMOUS BREAK»
Voir page 60



Plateau «LE CUBE»
«LE CUBE» Tray
Bandeja «LE CUBE»
Voir page 73



Assiette «JADE»
«JADE» Plates
Plato «JADE»
Voir page 95



Plateau «UENO»
«UENO» Tray
Bandeja «UENO»
Voir page 74



Ravier 1/2
Small Dish 1/2
Fuente 1/2
Voir page 74



Ravier 1/4
Small Dish 1/4
Fuente 1/4
Voir page 74

Voici le moment d'entrer dans le catalogue proprement dit !

Nous avons opté pour le classement des produits par familles. C'est plus facile et vous permettra de varier les plaisirs en terme de design et de matière !!

Vous retrouverez par exemple toutes nos verrines rassemblées dans les pages suivantes ainsi que leur associations aux différentes collections.

Nous avons aussi créé des vignettes pour vous faciliter la lecture qui reprennent les grandes qualités de nos produits.

Les différentes compositions possibles de nos plateaux sont enfin facilement reconnaissables avec des étiquettes dédiées qui renvoient aux pages où vous retrouverez toutes nos solutions de garnissage.

Collection « Esmeralda »

Collection « Frenchy folies »

Collection « O'Ronde »

Collection « Nect'Art »

Collection « Wood Mood »

Collection « Vision Verte »

Collection « Non Stop »



Matière biodégradable



Compatible avec Micro-onde



Compatible
avec Four traditionnel

Les Verrines «Universes»

page 26 - 59



Saladiers et mini-pots

page 105 - 110



Verrres

page 123 - 126



Plateaux repas

page 60 - 93



Coupes desserts

page 111 - 112



Serviettes et nappes

page 127 - 133



Assiettes

page 94 - 104



Couverts, sachets couverts et accessoires

page 113 - 122



Solutions transport



page 134 - 141



Verrines : Venise sur un plateau ...





Collection « Esmeralda »

VERRINE «VENISE» PS 5,5 CL
«VENISE» PS square verrine
Vasito cuadrado «VENISE» PS

 55x55x55 mm
 8450001TV/C
 600 (10x60)







VERRINE «VENISE» PS 12 CL
«VENISE» PS square verrine
Vasito cuadrado «VENISE» PS

 67x67x70 mm
 12 cl
 8450002TV/C
 480 (12x40)







VERRINE «VENISE» PS 18 CL
«VENISE» PS square verrine
Vasito cuadrado «VENISE» PS

 77x77x77xmm
 18 cl
 8450003TV/C
 480 (12x40)





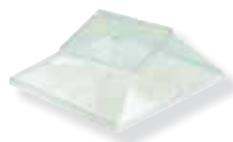

COUVERCLE PS
PS lid / Tapa PS

 70x70x25 mm
 -
 8450002COV/C
 480 (12x40)



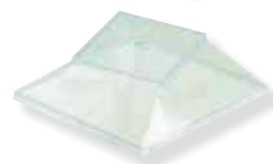

COUVERCLE PS
PS lid / Tapa PS

 79x79x32 mm
 -
 8450003COV/C
 480 (12x40)



VERRINE «PLAT» + ANSES PS TRANSPARENT VERT
PS transparent green dish verrine + Handles
Recipiente con asas PS transparente verde

 6,7x15xH3 cm
 40267TV
 576 (24x24)





VERRINE «ICE CUBE» PS TRANSPARENT VERT H4,5 CM
«ICE CUBE» PS transparent green square verrine
Vasito cuadrado transparente verde «ICE CUBE» PS

 L5xH4,5 cm
 846004TV
 1200 (50x24)



COUVERCLE PS
PS lid for Transparent Green Dish Verrine
Tapa para recipiente PS transparente verde

 7x5 cm
 40267TVCOV
 576 (24x24)







VERRINE «ICE CUBE» PS TRANSPARENT VERT H6,5 C CM
«ICE CUBE» PS transparent green square verrine
Vasito cuadrado PS transparente verde «ICE CUBE»

 L5xH6,5 cm
 8460005TV
 600 (50x12)







VERRINE «LUXAIR» 70x70 mm PET
PET «LUXAIR» verrine / Vasito «LUXAIR» PET

 70x70 mm
 -
 11327070
 -



VERRINE «LUXAIR» 70x115 mm PET
PET «LUXAIR» verrine / Vasito «LUXAIR» PET





 70x115 mm
 -
 113270115
 -



COUVERCLE PET
PET lid / Tapa PET

 70x70
 -
 11327070COV
 -

COUVERCLE PET
PET lid / Tapa PET

 70x115 mm
 -
 8450002COV/C
 -





Verrines : Mettez les bouchées doubles !

Collection « Esmeralda »



CUILLÈRE «MONACO» TRANSPARENT VERT PS
 «MONACO» PS transparent green appetiser spoon
 Cuchara «MONACO» PS transparente verde

 125x35x34 mm
 153125TV
 500 (10x50)

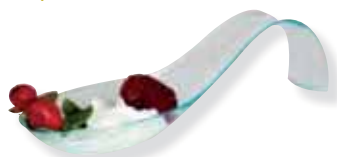

Variez les plaisirs !
 Existe aussi en noir et en blanc





153125N



153125B



CUILLÈRE «TAPAS» VERT TRANSPARENT PS
 «TAPAS» PS transparent green spoon
 Cuchara para «TAPAS» PS transparente verde

 105 x 45 x 25 mm
 1544310
 1000 (10x100)



Retrouvez toutes nos verrines « Frechie folies » p.50



CUILLÈRE «CHINOISE» CÉRAMIQUE
 «CHINESE» spoon
 Cuchara «CHINA» de cerámica

 15x60 mm
 0026102936054
 6



Retrouvez toutes nos verrines « Vision verte » p.45



VERRINE PULPE «1/2 OEUF»
 «HALF-OVAL-SHAPED» cellulose verrine
 Recipiente de pulpa prensada «SEMIOAVALADO»

 80 x 55 x 30 mm
 1451078
 200 (8x25)



Retrouvez toutes nos verrines « Vision verte » p.45

VERRINE PULPE «FEUILLE»
 «LEAF-SHAPED» cellulose verrine
 Recipiente de pulpa prensada «HOJA»

 105 x 51 x 29 mm
 1154010
 200 (8x25)



Pour présenter ces verrines, nous vous proposons :

PLATEAU «LUXE SOFT» [Réf. 0915029] Page 68



 Dimensions
 Dimensions

 Capacité
 Capacity

 Référence
 Reference

 Conditionnement
 Packaging

Verrines : Mini verres, maxi créativité !

Collection « Esmeralda »



le «Super-posable» [Réf. 0915030 / Page 138]

VERRINE «5TH AVENUE» PS TRANSPARENTE VERTE
«5th AVENUE» PS transparent green verrine
Vasito «5th AVENUE» PS transparente verde



7 cl
8430001TV
500

sur
précommande
No order / No encargo



VERRINE «5TH AVENUE» PS TRANSPARENTE
«5th AVENUE» PS Transparent Verrine
Vasito «5th AVENUE» PS transparente



7 cl
8430001T
300 (10x30)



Pour conditionner ces verrines,
nous vous proposons :



Le «Présentoir cristal 12 verrines»
[Réf. 0915005 / Page 57]



la «Boîte de transport»
[Réf. 120024 / Page 140]





Verrines

Collection « Esmeralda »



VERRINE «COROLLE» PS TRANSPARENT VERT

«COROLLE» PS transparent green verrine
Vasito «COROLLE» PS transparente verde

 8-9 cl
 843003TV
 300 (20x15)



VERRINE «LONGUE DRINK» PS TRANSPARENT VERT

«LONGUE DRINK» PS transparent green tube verrine
Vasito «LONGUE DRINK» PS transparente verde

 12 cl
 8420005TV
 360 (30x12)



VERRINE TRIANGLE «SEVILLE» PS TRANSPARENT VERT

«SEVILLE» PS transparent green triangle verrine
Vasito «SEVILLE» triangular PS transparente verde

 7 cl
 8430002TV
 600 (60x10)



VERRINE «CYLINDRIQUE» PS TRANSPARENT VERT

«CYLINDRIQUE» PS transparent green verrine
Vasito «CYLINDRIQUE» PS transparente verde

 7 cl
 8420004TV
 600 (30x20)



**Pour présenter ces verrines,
nous vous proposons :**

le plateau «LUXE SOFT» [Réf. 0915029 / Page 68]





Verrines : En plastique ou en verre, il n'y a plus qu'à laisser parler votre imagination !

Collection « Frenchy folies »



MINI BOCAL PS TRANSPARENT 4,5 CL / JOINT ORANGE



PS mini Jar 4,5 cl
Minitarro PS 4,5 cl

 H50/ø45 mm - 4,5 cl
 8470045
 240 (10x24)



MINI BOCAL PS TRANSPARENT 8 CL / JOINT ORANGE



PS mini Jar 8 cl
Minitarro PS 8 cl

 H70/ø45 mm - 8 cl
 8470080
 240 (10x24)



MINI BOCAL PS TRANSPARENT 30 CL / JOINT ORANGE

PS mini Jar 30 cl
Minitarro PS 30 cl

 H50/ø100 mm - 30 cl
 8470300
 60 (10x6)



Avez-vous pensez aux saladiers ? Retrouvez-les p. 105

BOCAL PET TRANSPARENT 12,5 CL / 20 CL / 35 CL

JOINT BLANC

PET jar 12,5 cl / 20 cl / 35 cl

Tarro PET 12,5 cl / 20 cl / 35 cl

Réf. 8470125 / 8470200 / 8470350



Transport facilité avec le plateau «BENTO» !

PLATEAU BENTO CARTON NOIR/RED RHODAMINE
(Réf. 1200320) Page 64



Verrines : Qui a parlé de la bonne confiture de grand-mère

Collection « Frenchy folies »



MINI BOCAL BAS VERRE TRANSPARENT 4,5 CL

Mini Jar 4.5 cl

Minitarro 4,5 cl



4,5 cl
96 (8x12)

Jouez avec les couleurs !

JOINT BLANC

white rubber seal
Goma blanca

 99V1114

JOINT VERT

Green Rubber seal
Goma verde

 99V1144

JOINT ROUGE

Red Rubber Seal
Goma roja

 99V1134

JOINT CHOCOLAT

Chocolate Brown
Rubber Seal
Goma marrón

 99V1184

JOINT ORANGE

Orange Rubber Seal
Goma naranja

 99V1164

JOINT BLEU

Blue Rubber Seal
Goma azul

 99V1124

JOINT ROSE

Pink Rubber Seal
Goma rosa

 99V1174

JOINT NOIR

Black Rubber Seal
Goma negra

 99V1154



Verrines

Collection «Frenchy folies»



PETIT BOCAL VERRE HAUT JOINT NOIR 6,5 CL

Small jar with black rubber seal
Tarro alargado pequeño con goma negra



6,5 cl
99V1156
96 (8x12)



PETIT BOCAL VERRE HAUT JOINT VERT 6,5 CL

Small jar with green rubber seal
Tarro alargado pequeño con goma verte

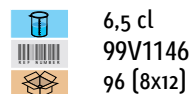

6,5 cl
99V1146
96 (8x12)



PETIT BOCAL VERRE HAUT JOINT BLANC 6,5 CL

Small jar with white rubber seal
Tarro pequeño con goma blanca

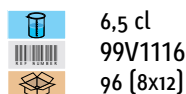

6,5 cl
99V1116
96 (8x12)



PETIT BOCAL VERRE HAUT ASSORTIMENT COULEURS 6,5 CL

Small Jar, Assorted Colours
Tarro pequeño de colores



6,5 cl
99V1366
96 (8x12)



PETIT BOCAL VERRE HAUT JOINT ORANGE 6,5 CL

Small jar with orange rubber seal
Tarro pequeño con goma naranja

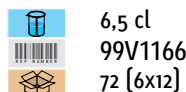

6,5 cl
99V1166
72 (6x12)



PETIT BOCAL VERRE HAUT JOINT BLEU 6,5 CL

Small jar with blue rubber seal
Tarro pequeño con goma azul

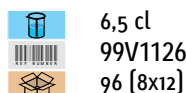

6,5 cl
99V1126
96 (8x12)



PETIT BOCAL VERRE HAUT JOINT ROUGE 6,5 CL

Small jar with red rubber seal
Tarro pequeño con goma roja



6,5 cl
99V1136
96 (8x12)



Verrines

Collection «Frenchy folies»

MINI POT À CONFITURE VERRE + COUVERCLE 4,4 CL

Mini jam jar

Minitarro para mermelada



4,4 cl



99V2114



96 (8x12)



POT À CONFITURE HAUT VERRE + COUVERCLE 10,6 CL

Jam jar

Tarro para mermelada



10,6 cl



99V21110



96 (8x12)



PETIT BOCAL CARRÉ VERRE JOINT BLANC 11 CL

Small square jar

pequeño cuadrado



11 cl



99V12111



96 (8x12)



POT À CONFITURE HEXAGONAL VERRE + COUVERCLE 10 CL

Hexagonal jam jar

Tarro hexagonal para mermelada



10,5 cl



H53AO105P



12



PETIT BOCAL CUBE VERRE JOINT ORANGE 10 CL

Small cube-shaped jar

Tarro pequeño cuadrado



11 cl



99V12611



96 (8x12)



PETIT BOCAL ROND VERRE JOINT BLANC 11 CL

Small round jar

Tarro pequeño redondo



11 cl



99V11111



96 (8x12)



MIGNONETTE TUBE À VIS VERRE 4 CL

Mini glass tube with screw cap

Minitubo de vidrio con tapón



4 cl



99V4104



96 (8x12)



MINI BOUTEILLE VERRE AVEC BOUCHON MÉCANIQUE 6,5 CL

Mini bottle with swing top

Minibotella con tapón



6,5 cl



99V3166



120 (10x12)



Verrines : Tradition ...

Collection «*Frenchy folies*»



«MINI COCOTTE» OVALE PP NOIRE + COUVERCLE 8 CL
PP black Oval «MINI CASSEROLE» + Lid
«CAZUELITA» PP ovalada negra + tapa



L7xL6,3xH3 cm - 8 cl
40270N
180 (30x6)



«MINI COCOTTE» RONDE PP NOIRE + COUVERCLE 8 CL
PP black Round «MINI CASSEROLE» + Lid
«CAZUELITA» PP redonda negra + tapa



8 cl
4020080N
200



«COCOTTE» RONDE PP NOIRE + COUVERCLE 30 CL
PP black Round «CASSEROLE» + Lid
«CAZUELITA» PP redonda negra + tapa



30 cl
4020300N
100



Pour compléter la gamme,
nous vous proposons :



CAISSE TRAITEUR KRAFT (Réf. 350338KB) Page 135



FOURCHETTE COCKTAIL ARGENT (Réf. 1513104) Page 115

CUILLERE COCKTAIL ARGENT (Réf. 1543104) Page 115



FOURCHETTE COCKTAIL TRANSPARENTE (Réf. 1513103) Page 118

CUILLÈRE COCKTAIL TRANSPARENTE (Réf. 1543103) Page 118



Verrines : Modernité !! ou l'inverse

Collection «Frenchy folies»



«MINI-COCOTTE» RONDE FAÏENCE ROUGE 20 CL

Red round «MINI CASSEROLE»
«TARTERITA» roja de cerámica



50x100 mm (20 cl)
3256390120516
6



«MINI-COCOTTE» OVALE FAÏENCE ROUGE 25 CL

Red Oval «MINI CASSEROLE»
«TARTERITA» roja de cerámica



50x130 mm (25 cl)
3256390120486
6



«MINI-COCOTTE» RONDE FAÏENCE NOIRE 20 CL

Black round «MINI CASSEROLE»
«TARTERITA» negra de cerámica



50x100 mm (20 cl)
3256390120515
6



«MINI-COCOTTE» OVALE FAÏENCE NOIRE 25 CL

Black Oval «MINI CASSEROLE»
«TARTERITA» negra de cerámica



50x130 mm (25 cl)
3256390120485
6



Également disponible en orange



Pour vos cocktails, optez
pour notre cuillère chinoise
en porcelaine !
Rendez-vous p.54
pour plus d'info.

Transport, plateaux repas,
Pensez «Bento» !
Rendez-vous p.66
pour plus d'info.

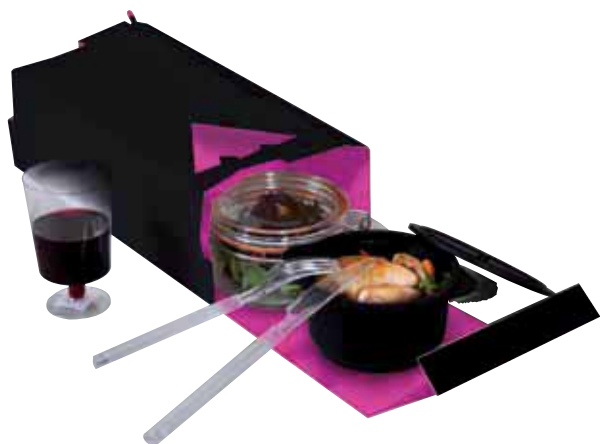

Osez l'originalité
avec nos assiettes cocktails
Ardoise type,
plus vrai que nature !
Toute la gamme p.55



Dimensions
Dimensions

Capacité
Capacity

Référence
Reference

Conditionnement
Packaging



Verrines : Rencontre du troisième type avec les Sphères Scoop

Collection «O'Ronde»



PETITE «SPHÈRE» PS 6 CL



Small PS «SPHERE»
«ESFERA» PS pequeña

 Ø57 mm H41 mm
 8410012
 200 (10x20)



MOYENNE «SPHÈRE» PS 15 CL



Medium PS «SPHERE»
«ESFERA» PS mediana

 Ø72 mm H49 mm
 8410013
 100 (10x10)



MOYENNE «SPHÈRE» PS 12 CL



Medium PS «SPHERE»
«ESFERA» PS mediana

 Ø65 mm H44 mm
 8410014
 200 (10x20)



GRANDE «SPHÈRE» PS 18 CL



Large PS «SPHERE»
«ESFERA» PS grande

 Ø74 mm H55 mm
 8410015
 100 (10x10)





«SPHÈRE SCOOP» PS

«SCOOP» PS bowl
Tazón «SCOOP» PS

 Ø 90x69 mm
 40190TV
 300 (6x50)



COUVERCLE PS / Lid / Tapa

 Ø 69 mm
 40190TVCOV
 300 (6x50)



Plus pratique !



Verrines : Simple fond, double fond, il ne reste qu'à garnir !



Collection «O'Ronde»

«SPHÈRE» BORD PLAT VERRE 19,5 CL
Glass «SPHERE» with Open Rim
Vaso «ESFERA» vidrio

 65x65 mm
 99V6319
 16



GRANDE «SPHÈRE» VERRE 24,4 CL
Large Glass «SPHERE»
Gran «ESFERA» vidrio

 63x65 mm
 99V6324
 12





Pour présenter ces verrines, nous vous proposons :

le plateau «LUXE SOFT» [Réf. 0915029 / Page 68]



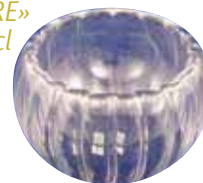

«SPHÈRE FLEUR» DOUBLE FOND VERRE 5 CL
Double-Walled Glass «FLOWER SPHERE»
«ESFERA FLOR» doble fondo vidrio 5 cl

 50x40 mm
 99V625
 sur commande



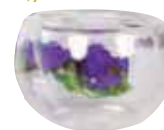

PETITE «SPHÈRE» DOUBLE FOND VERRE 1,7 CL
Small Double-Walled Glass «SPHERE»
«ESFERA» pequeña doble fondo vidrio 1,7 cl

 40x35 mm
 99V612
 20





MOYENNE «SPHÈRE» DOUBLE FOND VERRE 4 CL
Medium Double-Walled Glass «SPHERE»
«ESFERA» mediana doble fondo vidrio 4 cl

 50x40 mm
 99V614
 sur commande



GRANDE «SPHÈRE» DOUBLE FOND VERRE 5 CL
Large Double-Walled Glass «SPHERE»
«ESFERA» grande doble fondo vidrio 5 cl

 55x35 mm
 99V615
 sur commande



 Dimensions
Dimensions

 Capacité
Capacity

 Référence
Reference

 Conditionnement
Packaging



Verrines : Instant Thé ? L'ours de jouer !

Collection «Nect'Art»

Le mini bol «MING» est une forme classique de la dynastie du même nom (1522 - 1566). Reposant sur un petit pied, il est recouvert d'une belle glaçure colorée.



MINI BOL «MING» PS BICOLORE
«MING» PS two-colour mini bowl
 Minibol «MING» PS bicolor

 H25/ø45 mm
 846007
 200 (8x25)



COUVERCLE PS «MING»
 Lid «MING» PS
 Tapa «MING» PS

 -
 846007COV
 500



Coffret disponible sur commande



Verrines : Variez les plaisirs avec nos couleurs festives !!!

Collection «Nect'Art»

Pour compléter ces mini bols,
nous vous proposons :

Fourchette «COCKTAIL»
argent Réf.1513104
et cuillère «COCKTAIL»
argent Réf. 1543104
Voir page 115



MINI BOL «MING» PS BICOLORE COLORIS ASSORTIS
(BLEU, ROSE, VERT INTÉRIEUR BLANC) 3 CL

«MING» PS mini Bowl in several colours (blue, pink and green with white interior)

Minibol «MING» PS bicolor



Diam. 50 mm
846007A
225 (3x3x25)



COUVERCLE PS «MING»

Lid «MING» PS

Tapa «MING» PS



-
846007COV
500



 Dimensions
Dimensions

 Capacité
Capacity



 Référence
Reference

 Conditionnement
Packaging

Verrines : La soupe !



Collection «Nect'Art»

SOUPIÈRE PS «RODÉO DRIVE» NOIRE
 «RODEO DRIVE» PS black soup bowl
 Sopera cóctel «RODEO DRIVE» PS negra

 88x63x52 mm
 1410088N/C1
 500 (10x50)





SOUPIÈRE PS «RODÉO DRIVE» BLANCHE
 «RODEO DRIVE» PS white soup bowl
 Sopera cóctel «RODEO DRIVE» PS blanca

 88x63x52 mm
 1410088B/C1
 500 (10x50)



SOUPIÈRE «RODÉO DRIVE» PS TRANSPARENT VERT
 «RODEO DRIVE» PS transparent soup bowl
 Sopera cóctel «RODEO DRIVE» PS transparente

 88x63x52 mm
 1410088TV
 300



Pour compléter et présenter ces verrines, nous vous proposons :



Fourchette «COCKTAIL»
 argent Réf.1513104
et cuillère «COCKTAIL»
 argent Réf. 1543104
 Voir page 115



PLATEAU «LUXE SOFT»
 (Réf. 0915029) Page 68

VERRINE «HEXAGONALE» PS TRANSPARENTE + COUVERCLE



«HEXAGONAL» PS verrine + Lid
 Vasito «HEXAGONAL» PS + tapa

 8-10 cl
 8440010T
 576 (24x24)



VERRINE «PÉTALE» PS TRANSPARENT VERT

«PETALE» PS Transparent Green verrine
 Vasito «PETALE» PS transparente ver

 6xH4 cm
 40165TV
 720 (30x24)





Verrines : La soupe !



Collection «Nect'Art»





BOL «RIVIERA» PS TRANSPARENT VERT
«RIVIERA» PS transparent green bowl
Bol «RIVIERA» PS transparente verde

 75x35 mm
 40172TV
 500 (10x50)

BOL PS «RIVIERA» BLANC
«RIVIERA» PS white bowl
Bol «RIVIERA» PS blanco

 75x35 mm
 40172B
 500 (10x50)

BOL PS «RIVIERA» NOIR
«RIVIERA» PS black bowl
Bol «RIVIERA» PS negro

 75x35 mm
 40172N
 500 (10x50)



**Pour présenter ces verrines,
 nous vous proposons :**



PRÉSENTOIR YING YANG (Réf. 0915013) Page56

Verrines : *Ambiance Pin*

Collection «Wood Mood»





PETITE BARQUETTE PIN
Small pine serving boat
Cesta pequena de pino

 70 mm
 BIO330070
 4000 (40x100)





GRANDE BARQUETTE PIN
Large pine serving boat
Cesta grande de pino

 170x85x20 mm
 BIO330170
 2000 (20x100)



MOYENNE BARQUETTE PIN
Medium pine serving boat
Cesta mediana de pino

 115x65 mm
 BIO330110
 4000 (40x100)



Pour compléter cette gamme, retrouvez nos couverts en bois p.117



Verrines : Ambiance Bambou

Collection «Wood Mood»



COUPELLE CARRÉE BAMBOU Ø 60 MM
Small square bamboo dish
Fuente cuadrada bambú

60x60 mm
 1192006
 240 (10x24)



RAMEQUIN «SOLO ROND» BAMBOU
Bamboo «SOLO» ramekin
Ramequín «INDIVIDUAL» bambú

80x58 mm
 3282554113768
 12



COUPELLE RONDE CREUSE BAMBOU Ø 50 MM
Small round bamboo dish
Fuente redonda honda

Ø 50 mm
 3282554113778
 12



RAMEQUIN «DUO ROND» BAMBOU
Bamboo «DUO» ramekin
Ramequín «DOBLE» bambú

120x60 mm
 1191012
 120 (10x12)



COUPELLE CARRÉE INTÉRIEUR ROND BAMBOU 60x60 MM
Small square bamboo dish with round interior
Fuente cuadrada interior redondo bambú

60x60 mm
 1191206
 240 (10x24)



RAMEQUIN «TRIO ROND» BAMBOU
Round bamboo «TRIO» ramekin
Ramequín redondo «TRIPLE» bambú

176x58 mm
 1191018
 120 (10x12)



COUPELLE RONDE BAMBOU Ø 60 MM
Small round bamboo plate
Fuente redonda bambú

Ø 60 mm
 1191006
 240 (10x24)



RAMEQUIN «TRIO CARRÉ» BAMBOU
Square bamboo «TRIO» ramekin
Ramequín cuadrado «TRIPLE» bambú

180x60 mm
 1192018
 240 (10x24)



Verrines

Collection «Wood Mood»



CUILLÈRE «GOUTTE» BAMBOU

Bamboo «TEARDROP»
Cuchara «GOTA» bambú





 90x36 mm
 1591309
 240 [10x24]

CUILLÈRE «PELLE» BAMBOU

Bamboo «SCOOP»
Cuchara «PALA» bambú



 100x30 mm
 1591310
 240 [10x24]

Pour compléter et présenter ces verrines, nous vous proposons les accessoires suivants :

PIQUE DRAPEAU BAMBOU
Réf. 158105/158150/158180
et PIQUE NOEUD BAMBOU
Réf. 1580070/1580105/1580180
Page 119



PIQUE BAMBOU FOURCHETTE
Réf. 1580170
et PIC SUR PIED BAMBOU
Réf. 1580006
Page 119



PINCE BAMBOU
Réf. 1581090/1581150
Page 119



FOURCHETTE BAMBOU
Réf. 1591190
et CUILLÈRE BAMBOU
Réf. 1591390
Page 119



Fourchette bois
argent Réf.1591119
et Couteau bois
argent Réf. 1591219
Cuillère bois
Réf. 15911/C
Voir page 117



Plateau rectangulaire bois
Réf. BIO280420
Voir page 87



Verrines : Solutions durables

Collection «Vision Verte»



VERRINE PULPE «1/2 OEUF»

«HALF-OVAL- SHAPED» cellulose verrine
Recipiente pulpa «SEMIOAVALADO»



80 x 55 x 30 mm



1451078



200 [8x25]



COUPE PULPE RONDE DIAM.105

Round cellulose dish
Plato pulpa redondo



Diam. 105 mm



11511105



200 [8x25]



VERRINE PULPE «FEUILLE»

«LEAF-SHAPED» cellulose verrine
Recipiente pulpa «HOJA»



105 x 51 x 29 mm



1154010



200 [8x25]



COUPE PULPE CARRÉE 110x110

Square cellulose dish
Plato pulpa cuadrado



110x110 mm



11521115



200 [8x25]



Verrines : Formes de folies



VERRINE PS «MIAMI»

«MIAMI» PS Verrine
Vasito «MIAMI» PS

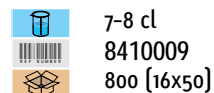

VERRINE PS «L.A.»

«L.A.» PS Verrine
Vasito «L.A.» PS



VERRINE PS «CENTRAL PARK»

«CENTRAL PARK» PS Verrine
Vasito «CENTRAL PARK» PS

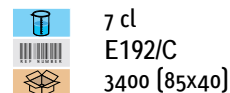

VERRINE PS «PARIS»

«PARIS» PS Verrine
Vasito «PARIS» PS

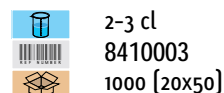

VERRINE PS «ST MORITZ»

«ST MORITZ» PS Verrine
Vasito «ST MORITZ» PS

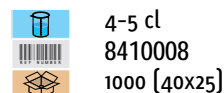

VERRINE PS «HOLLYWOOD»

«HOLLYWOOD» PS Verrine
Vasito «HOLLYWOOD» PS



COUVERCLES PS POUR VERRINES «ST MORITZ», «MIAMI», «L.A.»

Lids for «ST. MORITZ», «MIAMI» AND «L.A.» VERRINES
Tapas para vasitos «ST. MORITZ», «MIAMI» AND «L.A.»

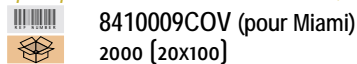

Verrines : Folies de formes

ASSIETTE PS «ST BARTH» NOIRE

«ST. BARTH» PS black plate
Platito «ST. BARTH» negro



80x80x12,45 mm
13580N
500 (10x50)

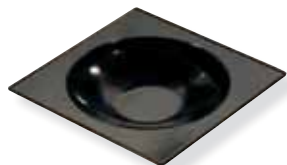

ASSIETTE PS «MAJORQUE» NOIRE

«MAJORQUE» PS black plate
Platito «MAJORQUE» negro



92x80x10 mm
13392N
500 (10x50)

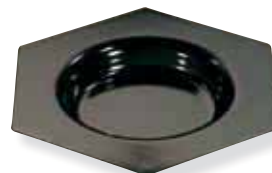

ASSIETTE PS «ST BARTH» BLANCHE

«ST. BARTH» PS white plate
Platito «ST. BARTH» blanco



80x80x12,4 mm
13580B
500 (10x50)



ASSIETTE PS «MAJORQUE» TRANSPARENT VERT

«MAJORQUE» PS transp. Green plate
Platito «MAJORQUE» transp. verde



92x80x10 mm
13392TV
500 (10x50)

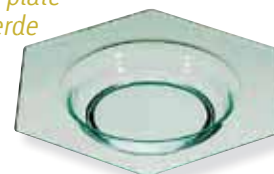

ASSIETTE PS «IBIZA» NOIRE

«IBIZA» PS black plate
Platito «IBIZA» PS negro



80x79x10 mm
13680N
500 (10x50)

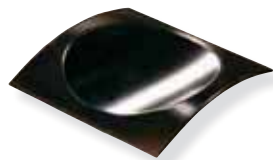

ASSIETTE PS «IBIZA» TRANSPARENT VERT

«IBIZA» PS transparent green plate
Platito «IBIZA» PS transparente verd



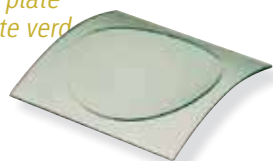

80x79x10 mm
13680TV
500 (10x50)



Verrines : Formes de folies





ASSIETTE PS «LAS VEGAS» TRANSPARENT VERT
«LAS VEGAS» PS transparent green plate
Platito «LAS VEGAS» PS transparente verde

 159x50x10 mm
 132159TV/C
 300 (6x50)



ASSIETTE PS «SPLIT» NOIRE
«SPLIT» PS black plate
Platito «SPLIT» PS negro

 86x49x10 mm
 13186N
 500 (10x50)





MINI-PLAT PS «KEY WEST» TRANSPARENT VERT
«KEY WEST» PS transp. green mini dish
Plato cóctel «KEY WEST» PS transp. verde

 76x76 mm
 1370075TV
 500 (10x50)





ASSIETTE PS «SPLIT» TRANSPARENT VERT
«SPLIT» PS transparent green plate
Platito «SPLIT» PS transparente verde

 86x49x10 mm
 13186TV
 500 (10x50)



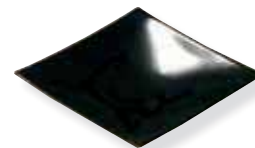

ASSIETTE PS «BEVERLY» NOIRE
«BEVERLY» PS black plate
Platito «BEVERLY» PS negro

 64x64x10 mm
 13564N
 500 (10x50)





ASSIETTE PS «SPLIT» BLANCHE
«SPLIT» PS white plate
Platito «SPLIT» PS blanco

 86x49x10 mm
 13186B
 500 (10x50)



ASSIETTE PS «BEVERLY» TRANSPARENT VERT
«BEVERLY» PS transparent green plate
Platito «BEVERLY» PS transparente verde

 64x64x10 mm
 13564TV
 500 (10x50)

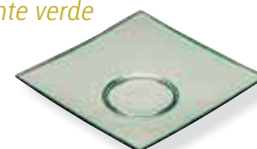

Verrines : Folies de formes



Pour transporter ces verrines, nous vous proposons :

BOÎTE DE TRANSPORT AVEC COUVERCLE
ATTENANT
(Réf. 120024) Page 140



CALAGE 12 VERRINES
POUR BOÎTE DE TRANSPORT AVEC COUVERCLE
ATTENANT
(Réf. 120024A) Page 140



Verrines : Quand le minéral s'en mêle !



VERRE À SMOOTHIE «BARISTA» EN VERRE «BARISTA» smoothie Glass Vaso para smoothies»BARISTA»



12 cl
5410808103561
6



22 cl
5410808103554
6



37 cl
5410808103578
6



VERRINE VERRE «DISCO» 5 CL «DISCO» Verrine Vasito «DISCO»



5 cl
5410808830634
6



VERRINE VERRE «DISCO» 9 CL «DISCO» Verrine Vasito «DISCO»



9 cl
5410808102663
6



VERRINE VERRE «DISCO» 42 CL «DISCO» Verrine Vasito «DISCO» ancho «dish»



42 cl
5410808103592
4

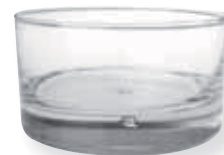

VERRINE VERRE «ATOLL» «ATOLL» Verrine Vasito «ATOLL»



11 cl
5410808102076
6



22 cl
5410808103318
6



Verrines : Verres en verre avez-vous dit ?

VERRINE VERRE «CARAT» 12 CL

«CARAT» verrine
Vasito «CARAT»



12 cl
5400808102670
6



VERRINE VERRE «CARAVELLE» 10 CL

«CARAVELLE» verrine
Vasito «CARAVELLE»



10 cl
8004360037319
6



VERRINE VERRE «CARAT» 21 CL

«CARAT» verrine
Vasito «CARAT»



21 cl
5400808103233
6



VERRINE VERRE «CARAVELLE» 15,5 CL

«CARAVELLE» verrine
Vasito «CARAVELLE»



15,5 cl
8004360037302
6



VERRINE VERRE «CARAVELLE» 20 CL

«CARAVELLE» verrine
Vasito «CARAVELLE»



20 cl
84360037296
6



VERRINE VERRE «CARAVELLE» DÉPOLIE 20 CL

«CARAVELLE» frosted verrine
Vasito esmerilado «CARAVELLE»



20 cl
84360037297
6



VERRINE VERRE «BARIL» 16 CL

«BARIL» verrine
Vasito «BARIL»



16 cl
0026102492475
6



VERRINE VERRE «FESTIVAL» 8 CL

«FESTIVAL» verrine
Vasito «FESTIVAL»



8 cl
3256390091280
6



VERRINE VERRE «COSMOS» 5 CL

«COSMOS» verrine
Vasito «COSMOS»



5 cl
5410808875208
6



VERRINE VERRE «FESTIVAL» ASSORTIMENT COULEURS 8 CL

«FESTIVAL» verrine in assorted colours
Vasito «FESTIVAL» de colores surtidos



8 cl
3256390099996
6



Verrines : Verres en verre avez-vous dit ?

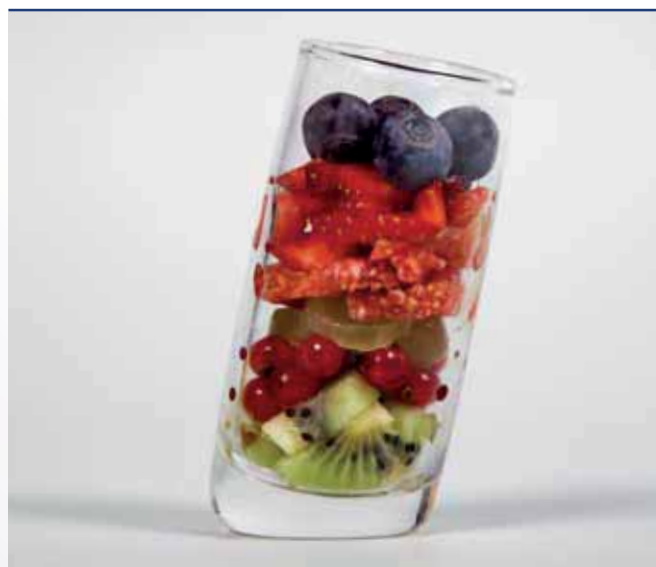

VERRINE VERRE «DUKE» 5 CL

«DUKE» verrine
Vasito «DUKE»

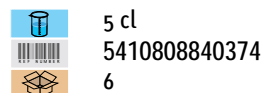

5 cl
5410808840374
6



VERRINE VERRE «CLUB» 6 CL

«CLUB» verrine
Vasito «CLUB»

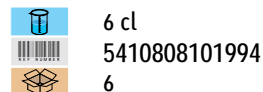

6 cl
5410808101994
6



VERRINE VERRE «LUDICO» 6 CL

«LUDICO» verrine
Vasito «LUDICO»

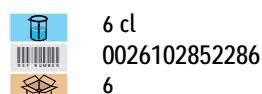

6 cl
0026102852286
6



VERRINE VERRE «LUDICO» 30 CL

«LUDICO» verrine
Vasito «LUDICO»

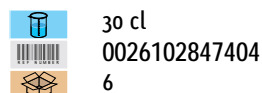

30 cl
0026102847404
6



VERRINE VERRE «BOSTON» 7 CL

«BOSTON» verrine
Vasito «BOSTON»

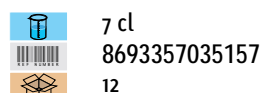

7 cl
8693357035157
12



VERRINE VERRE «ALANYA» 10 CL

«ALANYA» verrine
Vasito «ALANYA»

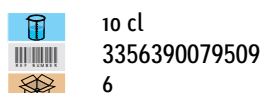

10 cl
3356390079509
6



VERRINE VERRE «NORWAY» 7 CL

«NORWAY» verrine
Vasito «NORWAY»

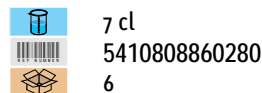

7 cl
5410808860280
6



VERRINE VERRE «SHETLAND» 9 CL

«SHETLAND» verrine
Vaso «SHETLAND»

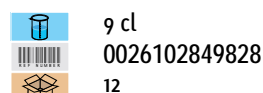

9 cl
0026102849828
12





Verrines : Une pyramide de créativité



VERRINE VERRE «BODEGA» 20 CL



«BODEGA» verrine
Vasito «BODEGA»

 20 cl
 8411712016456
 12 [2x6]



VERRINE VERRE PYRAMIDE «VERTIGO» 3 NIVEAUX FERMÉE



«VERTIGO» pyramid verrine
Vasito en pirámide «VERTIGO»

 37 cl / 22 cl / 12 cl
 000007539053
 6



VERRINE VERRE «BODEGA» 37 CL



«BODEGA» verrine
Vasito «BODEGA»

 37 cl
 8411712016432
 12



VERRINE VERRE PYRAMIDE «VERTIGO» 4 NIVEAUX FERMÉE



«VERTIGO» pyramid verrine
Vasito en pirámide «VERTIGO»

 37 cl / 22 cl / 12 cl / 12 cl
 541080810486
 2



VERRINE VERRE COUPE SANS PIED «HELSINKI» 25 CL



«HELSINKI» bowl verrine
Vasito copa «HELSINKI»

 25 cl
 5410808103301
 6



VERRINE VERRE COUPE SANS PIED «COMETA» 25 CL



«HELSINKI» bowl verrine
Vasito copa «HELSINKI»

 25 cl
 026102867846
 6



VERRE À TAPAS VERRE 20 CL

Tapas glass
Vaso para tapas

 20 cl
 3256390100043
 12



Verrines : Solutions traditionnelles

Collection «*Frenchy folies*»



COUPELLE CREUSE CARRÉE PORCELAINE* 10 CL

Small square porcelain dish
Bol cuadrado



55x85 mm (10 cl)
0026102935910
6



CUILLERE CHINOISE PORCELAINE*

Porcelain chinese spoon
Cuchara china



15x60 mm
0026102936054
6



ASSIETTE RECTANGULAIRE PORCELAINE*

Small rectangular porcelain plate
Plato rectangular



23x140x70 mm
0026102935934
6



COUPE «SPIRIT» PORCELAINE* 12 CL

«SPIRIT» porcelain bowl
Bol «SPIRIT»



40x102 mm (12 cl)
0026102936177
6



COUPE «LUDICO» PORCELAINE*

«LUDICO» porcelain bowl
Bol «LUDICO»



50x95 mm
0026102936153
6



* Autres modèles disponibles sur demande



La présentation et le transport



Collection «*Frenchy folies*»



Tradition, Modernité, choisissez votre matière !



Différents formats possibles

PLATEAU ARDOISE PS
PS slate tray
Bandeja pizarra PS

 300x200 mm
 3700022455129
 6





ASSIETTE COCKTAIL PS GRIS ARDOISE 20 x 20
Square grey PS slate tray
Plato cóctel PS gris pizarra

 200 x 200 x 16 mm
 1135820
 100 (10x10)





ASSIETTE COCKTAIL PS GRIS ARDOISE 30 x 14
Rectangular grey PS slate tray
Plato cóctel PS gris pizarra

 300 x 140 x 17 mm
 1132830
 80 (8x10)





ASSIETTE COCKTAIL PS GRIS ARDOISE 11 x 11
Square grey PS slate tray
Plato cóctel PS gris pizarra

 110 x 110 x 11 mm
 1135811
 320 (8x40)



ASSIETTE COCKTAIL PS GRIS ARDOISE 24 x 24
Square grey PS slate tray
Plato cóctel PS gris pizarra

 240 x 240 x 17 mm
 1135824
 80 (8x10)



La présentation et le transport





PRÉSENTOIR PLASTIQUE «KÉPHREN» 4 NIVEAUX «KEPHREN» display stand with 4 Tiers Expositor «KEPHREN»

 H720 mm
 0915312
 1
Niveaux :
650x570 mm
420x480 mm
340x390 mm
250x290 mm



PRÉSENTOIR PLASTIQUE «PISA» 5 NIVEAUX «PISA» display stand, 5 Tiers Expositor «PISA»

 H545 mm
 0915316
 1
5 niveaux 330x330 mm



PRÉSENTOIR PLASTIQUE «YING YANG» BLANC GIVRÉ 4 NIV. «YING YANG» display stand with 4 tiers Expositor «YING YANG»

 400x270 mm
 0915013
 1
Niveaux :
290 mm
210 mm
130 mm
50 mm



PRÉSENTOIR PLASTIQUE «OBÉLISQUE» ORANGE 4 NIVEAUX «OBELISQUE» display stand with 4 round tiers Expositor «OBELISQUE» con bandejas redonda

 Ø 390xH620 mm
 0915009
 1
Niveaux :
Ø 390 mm
Ø 310 mm
Ø 250 mm
Ø 190 mm



PRÉSENTOIR PLASTIQUE «ARROW» ORANGE 4 NIVEAUX «ARROW» display stand with 4 square tiers Expositor «ARROW» con bandejas rectangulares

 Ø 540x470xH630 mm 
 0915010
 1
Niveaux :
470x340 mm
370x250 mm
250x170 mm
230x130 mm



PRÉSENTOIR PLASTIQUE «SQUALE» ROUGE 4 NIVEAUX «SQUALE» display stand with 4 tiers Expositor «SQUALE» con bandejas redondas

 Ø 600x500xH600 mm 
 0915011
 1
Niveaux :
600x430 mm
490x350 mm
270x370 mm
250x180 mm



PRÉSENTOIR PLASTIQUE «GIZEH» VERT 4 NIVEAUX «GIZEH» display stand with 4 tiers Expositor «GIZEH» con bandejas circulares



 Ø 560xH620 mm 
 0915012
 1
Niveaux :
Ø 560 mm
Ø 460 mm
Ø 330 mm
Ø 220 mm



Retrouvez toutes les solutions de transport page 134

La présentation et le transport

PRÉSENTOIR PLASTIQUE «CRISTAL» 12 VERRINES sur commande
'CRISTAL' Display Tray 12 Verrines
Expositor Cristal 12 vasitos

 215x300x39 mm
 0915005
 2



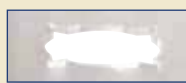

Idee de présentation →



découpes adaptées à plusieurs formes de verrines :
 8450001TV 8430002TV 8410009 8410007 8430001TV





ECRIN PS OR-NOIR 4 VERRINES sur commande
PS black gold tray for 4 verrines
Bandeja dorada 4 vasitos

 Ø 180 mm H50 mm
 0915008
 150





COUVERCLE PS ECRIN OR-NOIR 4 VERRINES sur commande
PS cover for black gold tray for 4 verrines
Tapa para bandeja dorada 4 vasitos

 Ø 180 mm
 0915008COV
 150





ECRIN PS OR-NOIR 8 VERRINES sur commande
PS black gold tray for 8 verrines
Bandeja dorada 8 vasitos

 Ø 260 mm H50 mm
 0915007
 100





COUVERCLE PS ECRIN OR-NOIR 8 VERRINES sur commande
PS cover for black gold tray for 8 verrines
Tapa para bandeja dorada 8 vasitos

 Ø 260 mm
 0915007COV
 100





ECRIN PS OR-NOIR 12 VERRINES sur commande
PS black gold tray for 12 verrines
Bandeja dorada 12 vasitos

 Ø 325x225 mm
 0915006
 100



COUVERCLE PS ECRIN OR-NOIR 12 VERRINES sur commande
PS cover for black gold tray for 12 verrines
Tapa para bandeja dorada 12 vasitos

 Ø 325x225 mm
 0915006COV
 100



La présentation et le transport



PLAT PET RECTANGULAIRE

PET rectangular serving tray
Fuente PET rectangular

460x300 mm
9827111/C
50

sur commande
to order/de encargo



PLAT PET OVAL ARGENT

PET silver oval serving tray
Fuente PET ovalada plateada

291 x 454 mm
9824116/C
25



PLAT PET «EUROPA»

PET «EUROPA» silver serving tray
Fuente PET plateada «EUROPA»

Ø 310 mm
9821112/C
25

sur commande
to order/de encargo

Ø 400 mm
9821114
50

sur commande
to order/de encargo



PLAT PET OVALE ARGENT

PET silver oval serving tray
Fuente PET ovalada plateada

353 x 549 mm
9824115/C
14



COUVERCLE PET PLATS «EUROPA»

PET Cover for «EUROPA» Silver Serving Tray
Tapa PET para fuentes «EUROPA»

Ø 400 mm
9653516
50

sur commande
to order/de encargo

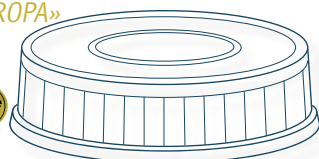

PLAT PET OCTOGONAL ARGENT

PET octagonal silver serving tray
Fuente PET octogonal plateada

255x385 mm
9823113/C
25

sur commande
to order/de encargo



PLAT PET «CLASSIQUE»

PET «CLASSIC» Serving Tray
Fuente PET «CLASSIC»

Ø 340 mm
9821113
50

sur commande
to order/de encargo

Ø 460 mm
9821115/C
50

sur commande
to order/de encargo



PLAT PET MARBRÉ NOIR OCTOGONAL

PET octagonal marbled black serving tray
Fuente PET octogonal jaspeada negra

385x255 mm
9823143/C
25

467x311 mm
9823144/C
25

sur commande
to order/de encargo



La présentation et le transport



PLAT PET OR OCTOGONAL
Gold octagonal serving tray
Fuente octogonal dorada

255x385 mm
9823123/C
25



PLAT PET OR OCTOGONAL
PET gold octagonal serving tray
Fuente octogonal dorada

300x300 mm
9823124/C
50 sur commande
to order/de encargo



MINI PLAT PET OR OCTOGONAL
PET gold octagonal mini serving tray
Fuentecita octogonal dorada

Ø 85 mm
9823120
1000 [8x125]



PLAT PET OR OCTOGONAL
PET gold octagonal serving tray
Fuente octogonal dorada

467x311 mm
9823125/C
25



Collection « Esmeralda »



PLATEAU «LUXE» PS VERT TRANSPARENT
«LUXE» PS Transparent green tray
Bandeja «LUXE» PS transparente verde

290 x 220 x 20 mm
0915029
50



COUVERCLE PET VERT TRANSPARENT
PET transparent green cover
Tapa PET transparente

330 x 255 x 50 mm
0915029COV
100

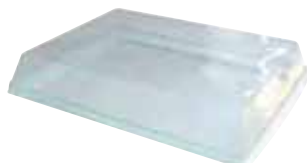

PLATEAU PS POUR 12 VERRINES
PS tray for 12 verrines
Bandeja PS para 12 vasitos

mm
0915021
25



COUVERCLE PS POUR PLATEAU POUR 12 VERRINES
PS cover for Tray for 12 verrines
Tapa PS para bandeja de 12 vasitos

mm
0915021COV
25



Dimensions
Dimensions

Capacité
Capacity

Référence
Reference

Conditionnement
Packaging

Plateaux repas

Collection «Non stop»

PLATEAU «FAMOUS BREAK»

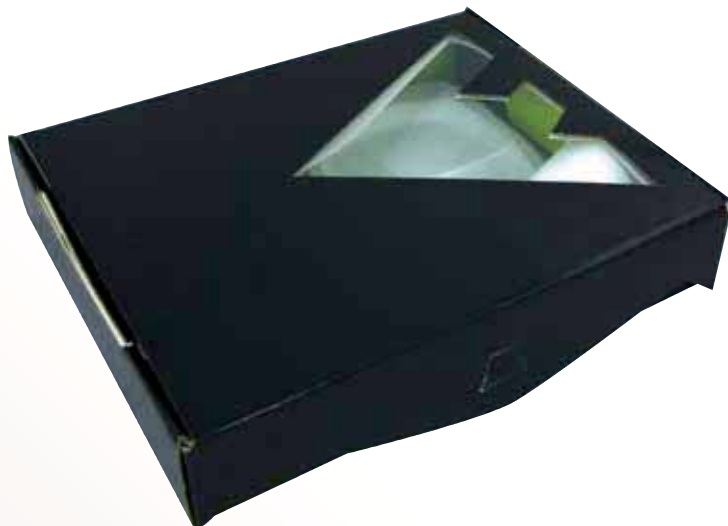

Fenêtre de visibilité
pour mettre en avant
vos produits.

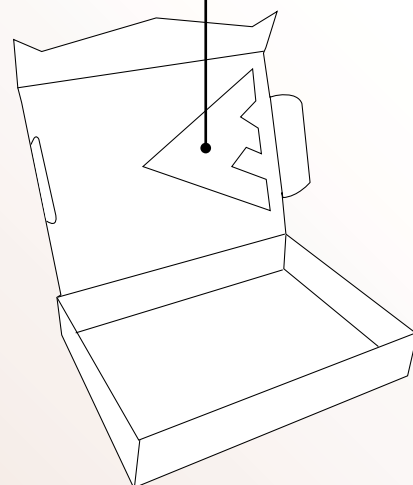

PLATEAU COFFRET «FAMOUS BREAK» CARTON NOIR/VERT
«FAMOUS BREAK» tray box in black and green cardboard
Caja con bandeja «FAMOUS BREAK» cartón negro/verde



367 x 285 x 70 mm

1201367

50

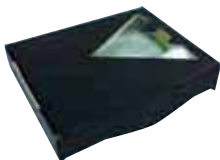

Nous vous proposons plusieurs compositions pour ce plateau...



Assiettes
thermoformées
PS vert transparent



Assiettes
injectées
PS vert transparent



Assiettes
moulées
«Vision Verte»



Plateaux repas

Les  :

- Design innovant
- Visibilité des produits
- Modularité
- Praticité

Collection «Non stop»



La Gamme «GOUTTE D'EAU» est destinée aux professionnels de la restauration rapide notamment à la recherche de vaisselle jetable pour préparations chaudes ou froides.

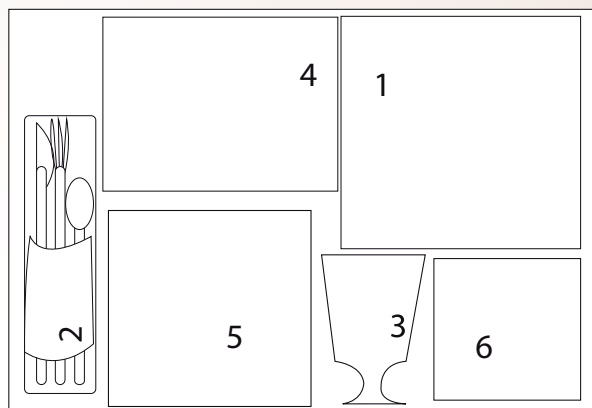

1 - GRANDE ASSIETTE «GOUTTE D'EAU» PET + COUVERCLE

Large «GOUTTE D'EAU» plate + lid
Plato grande «GOUTTE D'EAU» + tapa

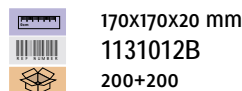

170x170x20 mm
1131012B
200+200



2 - SACHET COUVERTS PS TRANSPARENT 6 EN 1

(Couteau, Fourchette, Cuillère, Serviette, sel et poivre)
6-In-1 pack of PS transparent cutlery
(fork + knife + spoon + serviette + salt & pepper)
Bolsita cubiertos PS transparente 6 en 1: tenedor + cuchillo + cuchara de postre + servilleta + sal y pimienta

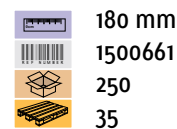

180 mm
1500661
250
35



3 - VERRE À PIED PS TRANSPARENT 20 cl

PS transparent stemmed glass
Copa PS transparente

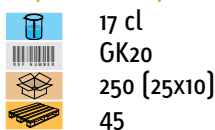

17 cl
GK20
250 (25x10)
45



4 - BOITE «FIRPACK» CARTON KRAFT BLANC

FIRPACK box in white cardboard
Caja de cartón kraft blanco «FIRPACK»



650 ml
1330110
450
16



5 - MOYENNE ASSIETTE «GOUTTE D'EAU» PET+ COUVERCLE

Medium «GOUTTE D'EAU» plate + lid
Plato mediano «GOUTTE D'EAU» + tapa

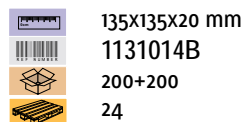

135x135x20 mm
1131014B
200+200
24



6 - RAVIER «GOUTTE D'EAU» PET + COUVERCLE

«GOUTTE D'EAU» dish + lid
Fuente «GOUTTE D'EAU» + tapa

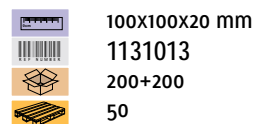

100x100x20 mm
1131013
200+200
50



Plateaux repas

Les  :

- Design épuré
- Visibilité des produits

Collection « Esmeralda »



La Gamme «JADE» est idéale pour les traiteurs et restaurateurs qui veulent présenter leurs préparations dans des contenants élégants, modernes et solides. Le coloris vert transparent permet d'ajouter une touche brillante et raffinée.

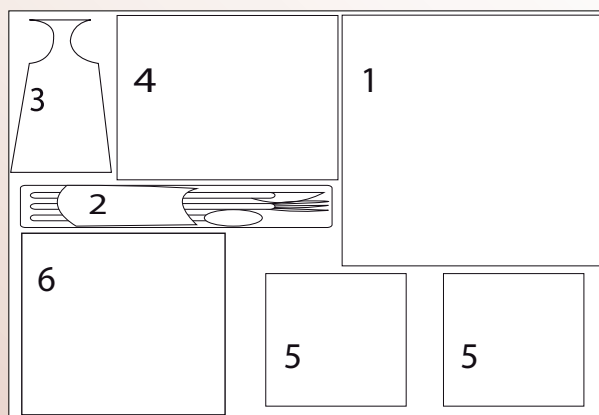

1 - ASSIETTE «JADE» PS TRANSPARENT VERT

«JADE» PS transparent green plate
Plato PS verde transparente

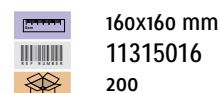

160x160 mm
11315016
200



1bis - COUVERCLE «JADE» PS TRANSPARENT VERT

«JADE» PS transparent green lid
Tapa PS verde transparente

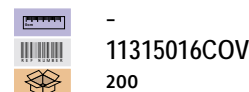

-
11315016COV
200

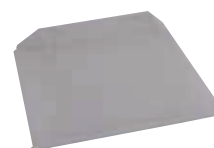

2 - SACHET COUVERTS PS TRANSPARENT 6 EN 1

(Couteau, Fourchette, Cuillère, Serviette, sel et poivre)
6-In-1 pack of transparent cutlery
(fork + knife + spoon + serviette + salt & pepper)
Bolsita cubiertos transparente 6 en 1 (tenedor + cuchillo + cuchara de postre + servilleta + sal y pimienta)

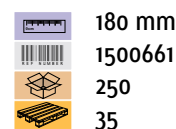

180 mm
1500661
250
35



3 - VERRE À PIED PS TRANSPARENT 20 cl

PS transparent stemmed glass
Copa PS

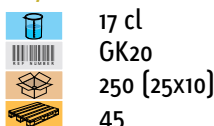

17 cl
GK20
250 [25x10]
45



4 - BOITE «FIRPACK» CARTON KRAFT BLANC

«FIRPACK» box in white cardboard
Caja «FIRPACK» cartón kraft blanco

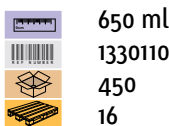

650 ml
1330110
450
16



6 - ASSIETTE «JADE» PS TRANSPARENT VERT

'JADE' Transparent Green Plate
Plato PS verde transparente

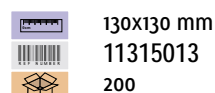

130x130 mm
11315013
200



6bis - ASSIETTE «JADE» PS TRANSPARENT VERT

'JADE' Transparent Green Lid
Tapa PS verde transparente

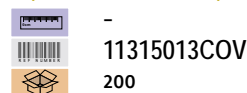

-
11315013COV
200

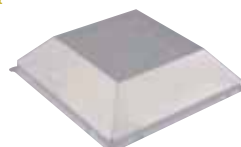

5 - ASSIETTE «JADE» PS TRANSPARENT VERT

«JADE» PS transparent green plate
Plato PS verde transparente



90x90 mm
11315009
200

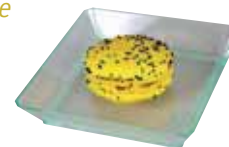

5bis - COUVERCLE «JADE» PS TRANSPARENT VERT

«JADE» PS transparent green lid
Tapa «JADE» PS verde transparente

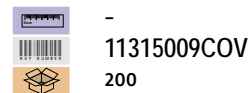

-
11315009COV
200

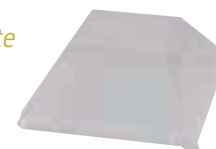

Plateaux repas

Les  :

- Protection de l'environnement
- Léger

Collection «Vision Verte»





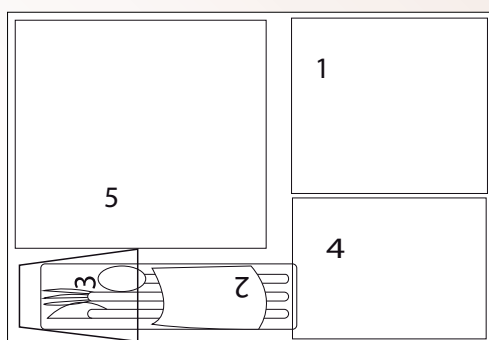

La Gamme «Vision verte» fabriquée à partir de pulpe de canne à sucre est idéale pour la vente à emporter. Ces contenants offrent de nombreux atouts : résistance et étanchéité aux sauces et aux graisses, micro-ondables jusqu'à 220 °C.



1 - BOL PULPE BLANC





White cellulose bowl
Bol de pulpa blanco

 150 x 150 x 40 mm
 145115
 300 (12x25)
 64



1 bis - COUVERCLE PET TRANSPARENT

Transparent PET lid
Tapa PET transparente





 165x160x40 mm
 145115COV
 300 (6x50)
 16



2 - SACHET COUVERTS 3 EN 1 LUXE BIODÉGRADABLE

[Couteau+Fourchette+Serviette]
3-In-1 pack of biodegradable cutlery





[knife + fork + serviette]
Bolsita de cubiertos 3 en 1 [cuchillo + tenedor + servilleta] biodegradables

 270 x 75 x 15 mm
 BIO1500630
 480
 40



3 - GOBELET PULPE BLANCHE





Cellulose tumbler
Vaso de pulpa blanco

 14 cl
 BIO826140
 1000 (40x25)
 24



5 - ASSIETTE PULPE CARREE 21 CM





Square cellulose plate
Plato de pulpa cuadrado

 210x210 mm
 1152121
 300 (12x25)
 25



5 bis - COUVERCLE RPET (PET RECYCLÉ)

Recycled PET lid
Tapa PET-R (PET reciclado)

 210x210 mm
 1152121COV
 300 (6x50)
 -



4 - BOITE «FIRPACK» CARTON RECYCLÉ KRAFT BRUN

«FIRPACK» recycled cardboard box
Caja «FIRPACK» cartón reciclado marrón

 650 ml
 1330130
 450
 16

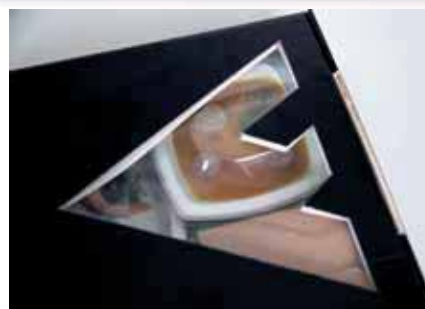

 Dimensions
Dimensions

 Capacité
Capacity

 Référence
Reference

 Conditionnement
Packaging

Plateaux repas

Collection «Non stop»

Les  :

- Design innovant
- Fonctionnel [set de table]

PLATEAU «BENTO»

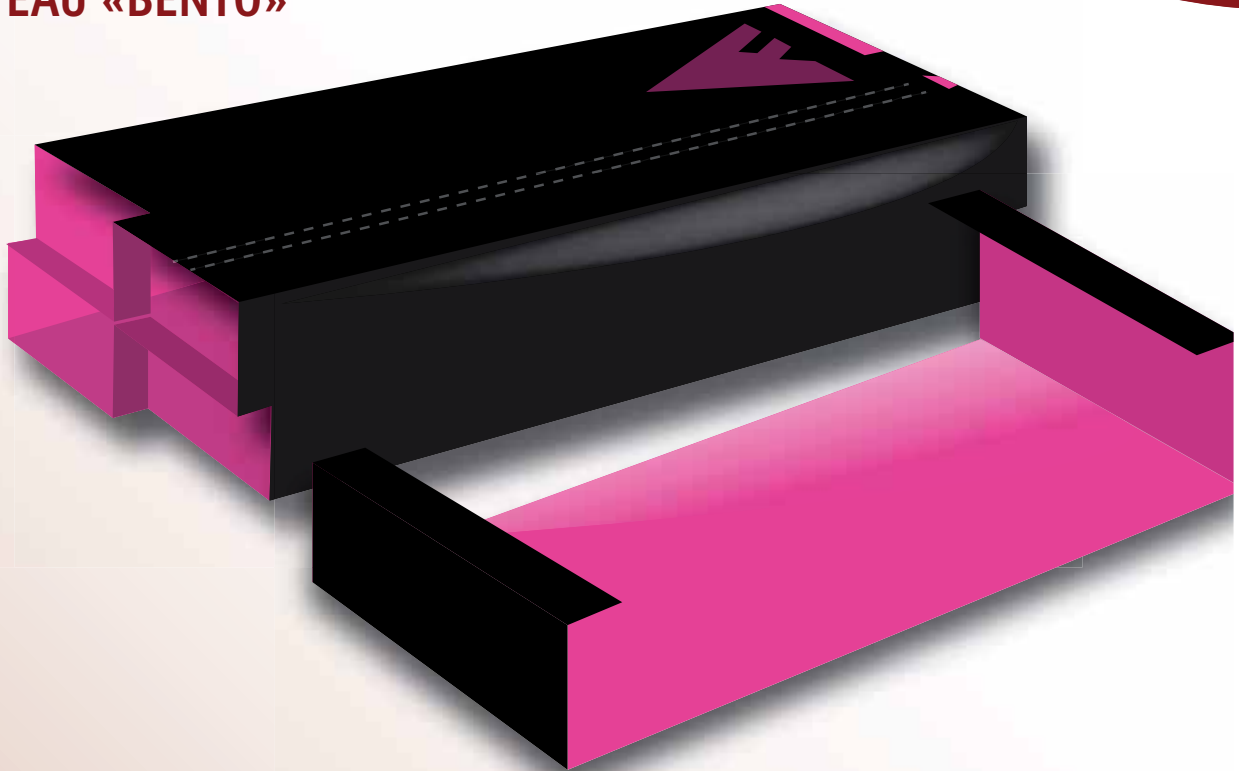

PLATEAU «BENTO» CARTON NOIR/RED RHODAMINE
+ CALE (300x140x90mm)

Black and pink «BENTO» cardboard tray

Bandeja «BENTO» cartón negro/rosa+soporte



320 X 140 X 90 mm



1200320



100

Le plateau «Bento» vous offre la possibilité de transporter votre repas ou vos verrines. Il allie la fonctionnalité d'un set de table et une esthétique originale.

Scénario d'usage :

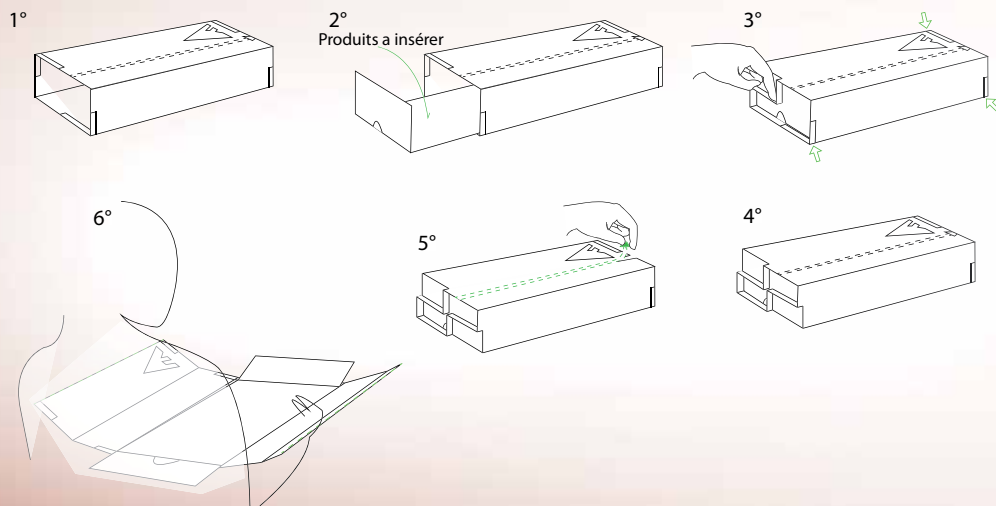

Plateaux repas

Les  :

- Modularité
- Bande d'arrachage

Collection «*Frenchy folies*»

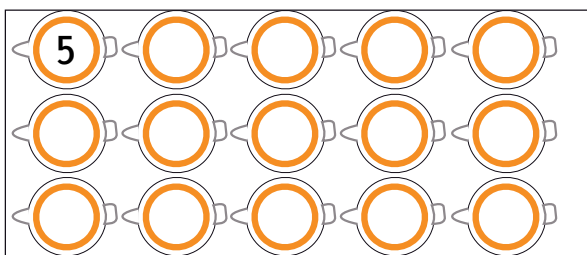

TRANSPORT DE VERRINES

Pot terroir haut



5 - MINI BOCAL «TERROIR» PLASTIQUE 6,5cl joint orange

«TERROIR» mini-jar in plastic
Minitarro «TERROIR» plástico

 6,5 cl
 99V1166
 72 (6x12)



 Dimensions
Dimensions

 Capacité
Capacity

 Référence
Reference

 Conditionnement
Packaging

Plateaux repas



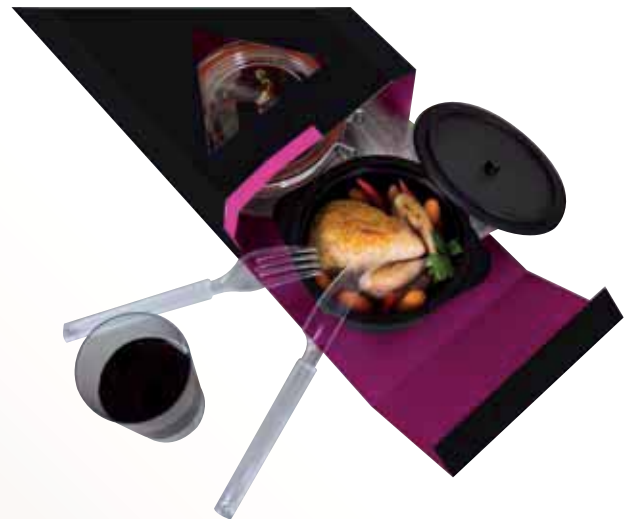
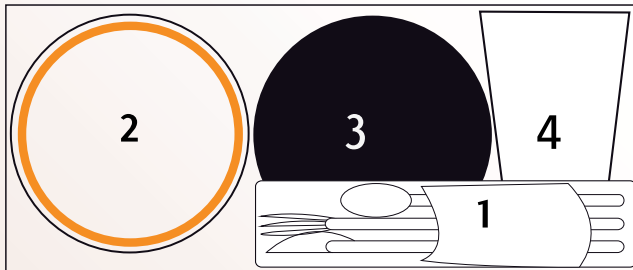

Les  :

- Modularité
- Bande d'arrachage

Collection «*Frenchy folies*»







1 - SACHET COUVERTS PS TRANSPARENT 6/1
 (Couteau, Fourchette, Cuillère, Serviette, sel et poivre
6-in-1 pack of transparent cutlery
[fork + knife + spoon + serviette + salt & pepper]
 Bolsita cubiertos transparentes ps 6 en 1
[Cuchillo, tenedor, cuchara, servilleta, sal y pimienta]

 180 mm
 1500661
 250
 35







2 - MINI BOCAL «TERROIR» PLASTIQUE 300 ML
 joint orange
«TERROIR» mini-jar in plastic
Minitarro «TERROIR» plástico

 105 x 105 x 65 mm
 8470300
 60 [10x6]
 -







3 - COCOTTE RONDE NOIRE PP 300 ML + COUVERCLE
Round black casserole + lid
Cazuelita redonda negra + tapa

 112 x 112 x 60 mm
 4020300N
 100
 2



4 - VERRE «CRISTAL» PS OCTOGONAL 25 cl
«CRISTAL» octagonal glass
Vaso «CRISTAL» octogonal

 25 cl
 7023
 1 000 [40x25]
 20



Plateaux repas

Les  :

- Visibilité des produits
- Modularité
- Praticité





page 95
JADE

Collection « Esmeralda »



La Gamme «JADE» est idéale pour les traiteurs et restaurateurs qui veulent présenter leurs préparations dans des contenants élégants, modernes et solides. Le coloris vert transparent permet d'ajouter une touche brillante et raffinée.

1 - SACHET COUVERTS PS TRANSPARENT 6/1
 [Couteau, Fourchette, Cuillère, Serviette, sel et poivre
 6-in-1 PS pack of transparent cutlery
 [fork + knife + spoon + serviette + salt & pepper]
 Bolsita cubiertos transparentes PS 6/1
 [Cuchillo, tenedor, cuchara, servilleta, sal y pimienta]

 180 mm
 1500661
 250
 35



2 - VERRE À VIN PS TRANSPARENT
 PS transparent stemmed wine glass
 Copa PS transparente

 17 cl
 GK20
 250
 45





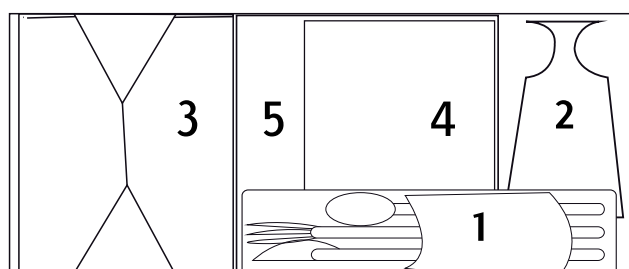

3 - BOITE «FIRPACK» CARTON KRAFT BLANC
 «FIRPACK» box in white cardboard
 Caja «FIRPACK» de cartón blanca

 650 ml
 1330110
 450
 16







4 - ASSIETTE PS INJECTÉ VERT TRANSPARENT 90 x 90
 PS transparent green plate
 Plato PS verde transparente

 90 x 90 x 20 mm
 11315009
 200
 120







4 bis - COUVERCLE PET TRANSPARENT
 Transparent PET lid
 Tapa PET transparente

 95 x 95 x 40 mm
 11315009COV
 200
 120







5 - ASSIETTE PS INJECTÉ VERT TRANSPARENT 130 x 130
 Transparent PS green plate
 Plato PS verde transparente

 130 x 130 x 20 mm
 11315013
 200
 72



5 bis - COUVERCLE PET TRANSPARENT
 Transparent PET lid
 Tapa PET transparente

 140 x 140 x 40 mm
 11315013COV
 200
 40



 Dimensions
 Dimensions

 Capacité
 Capacity

 Référence
 Reference

 Conditionnement
 Packaging

Plateaux repas

Collection « Esmeralda »

«LUXE SOFT»

Le Plateau «LUXE Soft» est idéal pour les traiteurs ou restaurateurs qui veulent présenter leurs préparations sur un plateau élégant, moderne et solide. Le coloris vert transparent du plateau repas permet d'ajouter une touche brillante et raffinée.

Les  :

- Élégant
- Visibilité des produits
- Solide







Ce plateau ne contient pas de couverts



Ce plateau ne contient pas de verre

PLATEAU LUXE PS VERT TRANSPARENT





«LUXE PS transparent green plate
Bandeja PS verte

	290 x 220 x 20 mm
	0915029
	50
	30



COUVERCLE PET VERT TRANSPARENT

Transparent PET lid
Tapa PET verte

	330 x 255 x 50 mm
	0915029COV
	100
	45

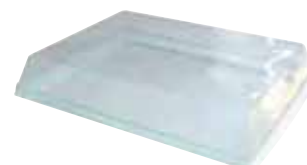

Nous vous proposons plusieurs compositions pour ce plateau...



Assiettes
thermoformées
PS vert transparent



Assiettes
injectées
PS vert transparent

Plateaux repas

Collection « Esmeralda »

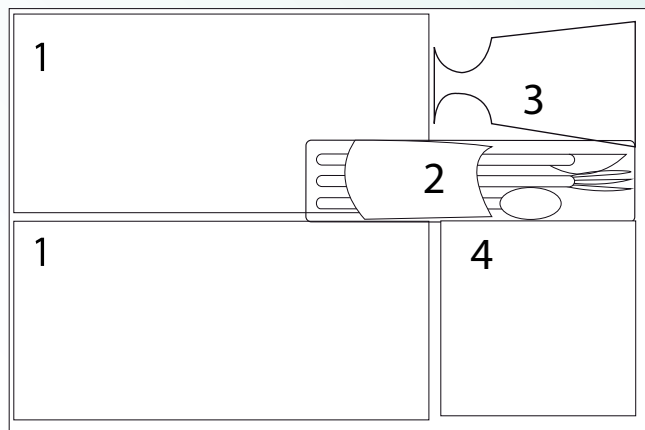

Une gamme élaborée et structurée pour vos plats fins et gourmets. Cette proposition vous offre la possibilité de mêler deux grands ravier pour vos compositions. Un verre et un set couverts pour un plateau complet.



1 - ASSIETTE PET BLANCHE RECTANGLE 170 x 100 + COUVERCLE PET VERT TRANSPARENT

White plate + Lid in PET
Plato PET rectangular blanco + tapa

	170 x 100 x 20 mm
	1131018B
	200 + 200
	32



3 - VERRE À PIED PS TRANSPARENT

PS transparent stemmed glass
Copa PS transparente

	17 cl
	GK20
	250 (25x10)
	45



2 - KIT COUVERTS INOX RÉUTILISABLE (FOURCHETTE, COUTEAU, PETITE CUILLÈRE, SERVIETTE)

Pack of reusable stainless cutlery
(fork, knife, spoon, serviette)

Kit cubiertos de acero inoxidable
(tenedor, cuchillo, cuchara, servilleta) reutilizable

	-
	0093119
	100
	54



4 - RAVIER PET VERT D'EAU 100 x 100 + COUVERCLE PET VERT TRANSPARENT

Small transparent green dish + lid in PET
Fuente PET verde agua+ tapa PET

	100 x 100 mm
	1131013
	200 + 200
	50



Dimensions
Dimensions

Capacité
Capacity

Référence
Reference

Conditionnement
Packaging

Plateaux repas

Les  :

- Élégant
- Visibilité des produits
- Solide



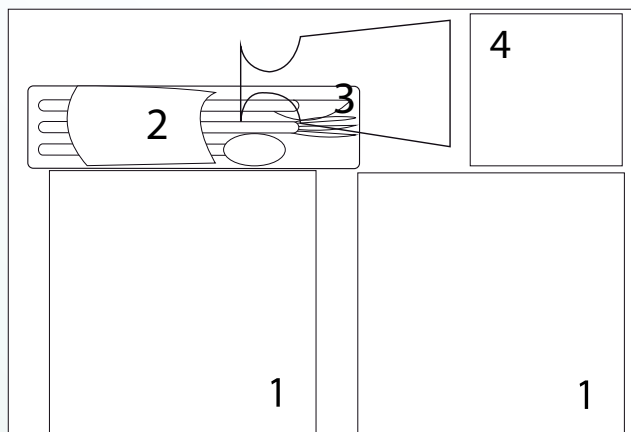

Collection « Esmeralda »

page 95
JADE



3 - VERRE À PIED PS TRANSPARENT





PS transparent stemmed glass
Copa PS transparente

 17 cl
 GK20
 250 (25x10)
 45



4 - ASSIETTE PS INJECTÉ VERT TRANSPARENT 90 x 90





Transparent green plate in PS
Plato PS verde transparente

 90 x 90 x 20 mm
 11315009
 200
 120



4 bis - COUVERCLE PET TRANSPARENT





Transparent PET lid
Tapa PET transparente

 95 x 95 x 40 mm
 11315009COV
 200
 120



1 - ASSIETTE PS INJECTÉ VERT TRANSPARENT 130 x 130





Transparent green PS plate
Plato PS transparente verde

 130 x 130 x 20 mm
 11315013
 200
 72



1 bis - COUVERCLE PET TRANSPARENT





Transparent PET lid
Tapa PET transparente

 140 x 140 x 40 mm
 11315013COV
 200
 40



2 - FOURCHETTE TRANSPARENTE «GIVRÉE» PS





Frosted PS transparent fork
Tenedor PS transparente

 180 mm
 1513318
 250 (10x25)
 -



2.1 - COUTEAU TRANSPARENT «GIVRÉ» PS





Frosted PS transparent knife
Cuchillo PS transparente

 190 mm
 1523319
 250 (10x25)
 -



2.2 - CUILLERE TRANSPARENTE «GIVRÉE» PS

Frosted PS transparent knife
Cuchara PS transparente

 170 mm
 1533318
 250 (10x25)
 -



2.3 - ÉTUI COUVERT KRAFT «BON APPÉTIT» + SERVIETTE

«BON APPÉTIT» cutlery case + serviette
Estuche para cubiertos «BON APPÉTIT» + servilleta

 200x85 mm
 0900302
 600
 30



Plateaux repas

Collection « Esmeralda »

Les  :

- Design épuré
- Visibilité des produits





PLATEAU «LUXE» 5 COMPARTIMENTS

Le Plateau «LUXE» dispose de 5 compartiments adaptés aux couverts et divers contenants. Son design épuré et transparent met en valeur toutes les préparations.



PLATEAU «LUXE» 5 COMPARTIMENTS PS VERT TRANSPARENT



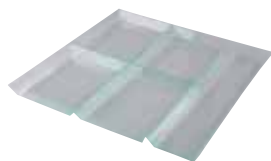

«LUXE» PS transparent green tray with 5 compartments
Bandeja PS verde transparente 5 compartimentos

 307 x 307 x 20 mm
 0915031
 25
 54



COUVERCLE PET VERT TRANSPARENT

Transparent green PET lid
Tapa PET verde transparente

 323 x 323 x 40 mm
 0915031COV
 50
 36

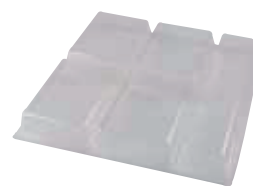

Ce plateau ne contient pas de couverts



Ce plateau ne contient pas de verre

Pour compléter ce plateau, nous vous proposons :

KIT COUVERTS INOX RÉUTILISABLE (FOURCHETTE, COUTEAU, PETITE CUILLÈRE, SERVIETTE)





Pack of reusable stainless cutlery
(fork, knife, spoon, serviette)
Kit cubiertos de acero inoxidable
(tenedor, cuchillo, cuchara, servilleta) reutilizable

 -
 0093119
 100
 54



VERRE À PIED PS TRANSPARENT

PS transparent stemmed glass
Copa PS transparente

 17 cl
 GK20
 250 [25x10]
 45



 Dimensions
Dimensions

 Capacité
Capacity

 Référence
Reference

 Conditionnement
Packaging

Plateaux repas

Les  :

- Design élaboré
- Composition riche
- Léger

PLATEAU «VAGUE»

Le Plateau «VAGUE» est idéal pour les traiteurs à la recherche de vaisselle aux lignes fines et épurées...

Il est composé de 1 assiette noire, 1 couvercle transparent, 2 rapiers 1/4 bordeaux ou beige et 1 ravier 1/2 bordeaux ou beige.







Ce plateau ne contient pas de couverts



Ce plateau ne contient pas de verre

PLATEAU «VAGUE» PS ROUGE





Red «VAGUE» Tray in PS
Bandeja «VAGUE» PS rojo

	245 x 245 mm
	1131001
	100
	30



PLATEAU «VAGUE» PS BEIGE

Beige «VAGUE» Tray in PS
Bandeja «VAGUE» PS blanco

	245 x 245 mm
	1131011
	100
	30



Plateaux repas

Collection «Non stop»



LE CUBE

CUBE BOX - CAJA TRANSPORTE

Le plateau par excellence
qui révolutionne le vente
à emporter.



**PLATEAU «CUBE» APET NOIR + 2/1 RAVIER PS
+ 2/4 RAVIER PS + COUVERCLE APET**
Black «CUBE» tray in APET + 1 1/2 Dish
+ 2 1/4 dishes in PS and Lid in APET
Bandeja «CUBE» PET negro + 2/1 fuente PS
+ 2/4 fuente PS + tapa PET

 305x320 mm
 09113032
 50



Ce plateau ne contient
pas de couverts



Ce plateau ne contient
pas de verre

Pour compléter ce plateau, nous vous proposons :

**KIT COUVERTS INOX RÉUTILISABLE
(FOURCHETTE, COUTEAU, CUILLÈRE, SERVIETTE)**





Pack of reusable stainless cutlery
{fork, knife, spoon, serviette}
Kit cubiertos de acero inoxidable {tenedor, cuchillo,
cuchara, servilleta} reutilizable

 -
 0093119
 100
 54



VERRE À PIED PS TRANSPARENT

PS transparent stemmed wine glass
Copa PS transparente

 17 cl
 GK20
 250 {25x10}
 45



 Dimensions
Dimensions

 Capacité
Capacity

 Référence
Reference

 Conditionnement
Packaging

Plateaux repas

Collection «Non stop»

PLATEAU OOKI

GAMME UENO

GAMME UENO -



Ce plateau ne contient pas de verre



Ce plateau ne contient pas de couverts

PLATEAU «OOKI» PS

«OOKI» Tray
Bandeja «OOKI»

380x275 mm
09123827
50



COUVERCLE «OOKI» APET

«OOKI» lid
Tapa «OOKI»

380x275 mm
09123827COV
50



RAVIER «OOKI» 1/2 PS 130x260 mm

«OOKI» 1/2 dish
Fuente «OOKI» 1/2

130x260 mm
113211326
50



RAVIER «OOKI» 1/4 PS 130x130 mm

«OOKI» 1/4 Dish
Fuente «OOKI» 1/4

130x130 mm
113211313
100



Toutes nos solutions couverts Page 113

KIT COUVERTS INOX RÉUTILISABLE (FOURCHETTE, COUTEAU, CUILLÈRE, SERVIETTE)

Pack of reusable stainless cutlery
(fork, knife, spoon, serviette)
Kit cubiertos de acero inoxidable (tenedor, cuchillo, cuchara, servilleta) reutilizable

-
0093119
100
54



VERRE À PIED PS TRANSPARENT

PS transparent stemmed glass
Copa PS transparente

17 cl
GK20
250 (25x10)
45



Plateaux repas

Collection «Non stop»

GAMME UENO

GAMME UENO -

PLATEAU CHISAÏ



Ce plateau ne contient pas de verre



Ce plateau ne contient pas de couverts

SOUS-ASSIETTE «CHISAÏ» PS 245x245 MM

«CHISAÏ» service plate
Bajoplato «CHISAÏ»

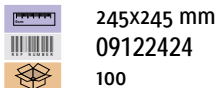

245x245 mm
09122424
100



COUVERCLE «CHISAÏ» APET 245x245 MM

Lid for «CHISAÏ» service plate
Tapa para bajo plato «CHISAÏ»

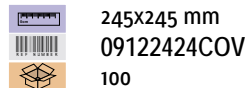

245x245 mm
09122424COV
100



RAVIER «CHISAÏ» 1/2 PS 115x225 MM

«CHISAÏ» 1/2 Dish
Fuente «CHISAÏ» 1/2

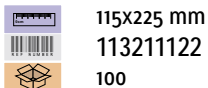

115x225 mm
113211122
100



RAVIER «CHISAÏ» PS 1/4 115x115 MM

«CHISAÏ» 1/4 Dish
Fuente «CHISAÏ» 1/4

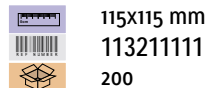

115x115 mm
113211111
200



Pour compléter ce plateau, nous vous proposons :

SACHET COUVERTS 6/1 «LUXE» TRANSPARENT (fourchette, couteau, cuillère, serviette, poivre et sel)

6-In-1-pack of transparent cutlery
(fork + knife + spoon + serviette + salt & pepper)
Bolsita cubiertos transparente 6 en 1 (tenedor, cuchillo, cuchara de postre, servilleta, sal y pimienta)



-
1500661
250



VERRE À PIED PS TRANSPARENT

Transparent stemmed glass copa PS
Copa PS transparente

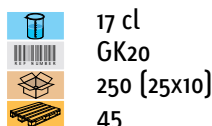

17 cl
GK20
250 (25x10)
45



Plateaux repas

SALADIER WAN

GAMME UENO

GAMME UENO -



Ce plateau ne contient pas de verre



Ce plateau ne contient pas de couverts

SOUS-ASSIETTE «WAN» PS 215x215 MM

«WAN» service plate
Bajoplato «WAN»



215x215 mm
11354215
100



COUVERCLE «WAN» APET 215x215 MM

Lid for «WAN» Service Plate
Tapa para bajoplato «WAN»



215x215 mm
11354215COV
100



SALADIER «WAN» PS 200x200 MM

«WAN» Salad Bowl
Ensaladera «WAN»



200x200 mm
11351200
100



Pour compléter ce plateau, nous vous proposons :

KIT COUVERTS INOX RÉUTILISABLES

{fourchette, couteau, cuillère, serviette}

Pack of reusable stainless cutlery

{fork, knife, spoon, serviette}

Kit cubiertos de acero inoxidable {tenedor, cuchillo, cuchara, servilleta}



-
0093119
100
54



VERRE À PIED PS TRANSPARENT

PS transparent stemmed glass

Copa PS transparente



17 cl
GK20
250 (25x10)
45



Plateaux repas

GAMME UENO

GAMME UENO -

PLAT OSARA



Ce plateau ne contient pas de verre



Ce plateau ne contient pas de couverts

SOUS-ASSIETTE «OSARA» PS

«OSARA» Service Plate
Bajoplato Plat «OSARA»



195x195 mm
11354195
100



COUVERCLE «OSARA» APET

Cover for ueno «OSARA» service platetapa para bajo plato tapa para bajoplato ueno plat osara



195x195 mm
11354195COV
100



ASSIETTE PLAT «OSARA» PS

'OSARA' Plate
Plato Plat Osara



180x180 mm
11351180
100



Pour compléter ce plateau, nous vous proposons :

KIT COUVERTS INOX RÉUTILISABLES

[fourchette, couteau, cuillère, serviette]

Pack of reusable stainless cutlery

[fork, knife, spoon, serviette]

Kit cubiertos de acero inoxidable: tenedor + cuchillo + cuchara + servilleta



-
0093119
100
54



VERRE À PIED PS TRANSPARENT

PS transparent stemmed glass

Copa PS transparente



17 cl
GK20
250 (25x10)
45



 Dimensions
Dimensions

 Capacité
Capacity

 Référence
Reference

 Conditionnement
Packaging

Plateaux repas

Collection «Vision Verte»



Les  :

- Matériau biodégradable
- Plusieurs compartiments
- Léger

«PLATEAU VISION VERTE» Petit format

Ce plateau est destiné principalement aux professionnels de la restauration soucieux du geste éco-responsable pour un confort identique voir meilleur à des plateaux repas en plastique traditionnels.







Ce plateau ne contient pas de couverts



Ce plateau ne contient pas de verre







PLATEAU PULPE
Cellulose tray
Bandeja de pulpa

 280 x 220 x 35 mm
 1352822
 (4x50)
 30







COUVERCLE PULPE POUR PLATEAU PULPE
Cellulose lid for cellulose tray
Tapa pulpa para bandeja pulpa

 295 x 240 mm
 1352822COV
 (4x50)
 30







Avec ces plateaux, nous vous proposons :

SACHET COUVERTS 3 EN 1 LUXE BIODÉGRADABLE
[Couteau+Fourchette+Serviette]
3-In-1 pack of biodegradable cutlery
[Knife + fork + serviette]
Bolsita de cubiertos 3 en 1 [cuchillo + tenedor + servilleta]

 270 x 75 x 15 mm
 BIO1500630
 480
 40







SACHET 3/1 BOIS (Couteau+Fourchette+Cuillère)
3-In-1 pack of wooden cutlery [knife + fork + spoon]
Bolsita cubiertos 3 en 1 madera
[Cuchillo + tenedor + cuchara]

 165 mm
 1590630
 250
 72







GOBELET PULPE 26 CL
Cellulose tumbler - Vaso de pulpa

 20-26 cl / 9 oz
 BIO826200
 750 (30x25)
 24



SERVIETTE Papier recyclé marron 1 pli
1-Ply brown recycled paper serviette
Servilleta de papel reciclado marrón 1 capa

 30x30 mm
 611113/C
 3200 (16x200)
 20



Plateaux repas

Collection «Vision Verte»



Les  :

- Matériau biodégradable
- Espace optimisé
- Esthétique soulignée

PLATEAU «VISION VERTE» Grand format

Fabriqué à partir de pulpe de canne à sucre, ce plateau offre de nombreux atouts : résistant et étanche aux sauces et aux graisses, il dispose de 5 compartiments permettant de présenter un repas complet accompagné de couverts et sauces. Ce plateau bénéficie également d'un couvercle en Pet recyclé (vendu séparément).



La base de ce plateau est compostable

PLATEAU PULPE
Cellulose tray
Bandeja pulpa



375 x 270 x 30 mm
1353827
200 (4x50)
-



COUVERCLE TRANSPARENT RPET
Transparent RPET lid for cellulose tray
Tapa transparente PET-R para bandeja pulpa



385 x 275 x 45 mm
1353827COV
Matériau recyclé = RPET



 Dimensions
Dimensions

 Capacité
Capacity

 Référence
Reference

 Conditionnement
Packaging

Plateaux repas

Les  :

- Design original
- Praticité pour le transport

PLATEAU «PRESTIGE»

Le Plateau «Prestige» est un **kit complet** et esthétique grâce à sa forme originale.





Nous vous simplifions la vie, ce plateau est déjà complet !

Il est composé de 2 ravers ovoïdes blancs, 2 ravers quart de cercle blancs, 1 assiette blanche **micro-ondable**, 1 verre à pied cristal 20cl, 1 sachet couverts 6 en 1 standard [couteau, fourchette, petite cuillère, serviette, sel et poivre] et 1 couvercle transparent. Ce plateau existe en 2 coloris : noir ou bordeaux.



PLATEAU «PRESTIGE» PS NOIR





Black «PRESTIGE» tray with 6 compartments + 4 white ramekins + 1 microwavable plate + 1 wine glass + 6-in-1 cutlery
Bandeja «PRESTIGE» 6 compartimentos: 4 fuentes blancas +plato para microondas+vaso +bolsita de cubiertos +tapa transparente

 465 x 300 x 63 mm
 4005610
 50
 16



PLATEAU «PRESTIGE» PS BORDEAUX

Burgundy «PRESTIGE» tray with 6 compartments + 4 white ramekins + 1 microwavable plate + 1 wine glass + 6-in-1 cutlery pack + transparent lid
Bandeja «PRESTIGE» 6 compartimentos : 4 fuentes blancas+plato para microondas+vaso+bolsita de cubiertos +tapa transparente

 465 x 300 x 63 mm
 4005620
 50
 16



Plateaux repas

Les  :

- Esthétique soulignée
- Composition riche
- Praticité

PLATEAU «PLAT DU JOUR»

Le Plateau «PLAT DU JOUR» combine design et praticité avec ses 5 compartiments.

Il est composé d'une assiette ivoire, de deux ravers ivoires, et un couvercle transparent.

A savoir que seuls les ravers ivoires sont micro-ondables.



Pour compléter ce plateau, nous vous proposons :

PLATEAU «PLAT DU JOUR» BORDEAUX

«PLAT DU JOUR» [daily special] tray with 5 compartments + 3 ivory ramekins + 1 burgundy tray + transparent lid
Bandeja burdeos «PLAT DU JOUR» 5 compartimentos : 3 fuentes + tapa transparente



416 x 322 x 60 mm
0915000
50
16



SACHET COUVERTS PS TRANSPARENT 6 EN 1 (Couteau, Fourchette, Cuillère, Serviette, sel et poivre)

6-In-1 PS pack of transparent cutlery (fork + knife + spoon + serviette + salt & pepper)
Bolsita cubiertos PS transparente 6 en 1: tenedor + cuchillo + cuchara de postre + servilleta + sal y pimienta



180 mm
1500661
250
35



VERRE «CRISTAL» PS OCTOGONAL 25 cl

Octogonal «CRISTAL» tumbler
Vaso «CRISTAL» octogonal



25 cl
7023
1 000 [40x25]
20



Plateaux repas

Les  :

- Composition ergonomique
- Praticité
- Léger





PLATEAU «PAUSE DÉJEUNER»

Destiné notamment aux collectivités, la gamme «PAUSE DEJEUNER» allie qualité et modularité. Pratique, ce plateau dispose de 5 compartiments et d'un couvercle (vendu séparément).



PLATEAU «PAUSE DEJEUNER» PS BEIGE





Ivory «PAUSE DEJEUNER» (lunch break) tray
Bandeja PS «PAUSE DEJEUNER»

 342 X 242 X 30 mm
 0915019
 200
 16



COUVERCLE PS TRANSPARENT

Transparent lid
Tapa PS transparente





 345 X 245 X 30 mm
 0915019COV
 200
 12



Pour compléter ce plateau, nous vous proposons :

GOBELET PS «CRISTAL» TRANSPARENT 20/23 CL





«CRISTAL» tumbler - Vaso «CRISTAL»

 20-23 cl
 82212500
 1000 (20x50)
 32



SACHET 6/1 BLANC : FOURCHETTE + COUTEAU +

PETITE CUILLERE + SERVIETTE + POIVRE & SEL
6-In-1 pack of transparent cutlery
(fork + knife + spoon + serviette + salt & pepper)
Bolsita cubiertos blancos 6 en 1 : tenedor + cuchillo +
cuchara de postre + servilleta + sal y pimienta

 -
 1500660
 250
 49



Plateaux repas

Dernier arrivé
mais qui promet déjà beaucoup !

GAMME SHINJUKU

GAMME SHINJUKU

PLATEAU TOKUDAÏ



Ce plateau ne contient pas de verre



Ce plateau ne contient pas de couverts



PLATEAU «TOKUDAÏ» 305x440 mm

«TOKUDAÏ» tray
Bandeja «TOKUDAÏ»

305x440 mm
09153044
100



GRANDE ASSIETTE «TOKUDAÏ» PS 145x275 mm +COUVERCLE

PS large «TOKUDAÏ» plate
Plato PS grande «TOKUDAÏ»

145x275 mm
113201427
100



PETITE ASSIETTE «TOKUDAÏ» APET 135x145mm +COUVERCLE

APET small «TOKUDAÏ» plate
Plato pequeño «TOKUDAÏ» APET

135x145 mm
113201314
100



Pour compléter ce plateau, nous vous proposons :

FOURCHETTE TRANSPARENTE «GIVRÉE» PS

PS frosted transparent fork
Tenedor PS transparente

180 mm
1513318
250 (10x25)
-



VERRE À PIED PS TRANSPARENT

PS transparent stemmed glass
Copa PS transparente

17 cl
GK20
250 (25x10)
45



COUTEAU TRANSPARENT «GIVRÉ» PS

PS frosted transparent knife
Cuchillo PS transparente

190 mm
1523319
250 (10x25)
-



CUILLÈRE TRANSPARENTE «GIVRÉE» PS

PS frosted transparent spoon
Cuchara PS transparente

170 mm
1533318
250 (10x25)
-



ÉTUI COUVERT «BON APPÉTIT» + SERVIETTE

«BON APPÉTIT» cutlery case + serviette
Estuche para cubiertos «BON APPÉTIT» + servilleta

200x85 mm
0900302
600
30



Plateaux repas

Les  :

- Matériau développement durable
- Transport optimisé



PLATEAU «MUST» AVEC TIROIR





Le plateau «MUST» version «Light» dispose d'une ergonomie et d'une résistance permettant un transport en toute sécurité des repas. D'un habillage blanc et sobre, ce plateau repas avec couvercle est personnalisable par 5000.



Pour compléter ce plateau, nous vous proposons :



PLATEAU «LIGHT» CARTON BLANC

«LIGHT» cardboard box tray - Caja cartón «LIGHT» blanca

	400 x 300 x 70 mm	
	20BT395ECO	
	50 100	

PLATEAU COFFRET «PRESTIGE» CARTON IVOIRE

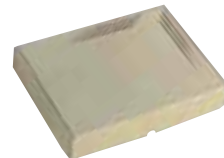
«PRESTIGE» transport box - caja «PRESTIGE» cartón marfil

	400 x 300 x 70 mm	
	20BT395PPT	
	50 -	







Ce plateau ne contient pas de couverts



Ce plateau ne contient pas de verre





ASSIETTE PET BLANCHE 170 x 170 x 20 AVEC COUVERCLE PET VERT TRANSPARENT

PET large white plate + lid
Plato grande PET blanca + tapa

	170 x 170 x 20 mm	
	1131012B	
	200 + 200 16	





ASSIETTE PET BLANCHE 135 x 135 x 20 AVEC COUVERCLE PET VERT TRANSPARENT

PET medium white plate + lid
Plato mediano PET blanca + tapa

	135 x 135 x 20 mm	
	1131014B	
	200 + 200 24	





ASSIETTE PET BLANCHE 170 x 100 AVEC COUVERCLE PET VERT TRANSPARENT

PET white plate + lid
Plato blanco PET + tapa

	170 x 100 x 20 mm	
	1131018B	
	200 + 200 32	





RAVIER PET VERT TRANSPARENT 100 x 100 AVEC COUVERCLE PET VERT TRANSPARENT

PET small transparent green plate + lid
Fuente pequeña PET verde transparente + tapa

	100 x 100 mm	
	1131013	
	200 + 200 50	

TIROIR CARTON BLANC POUR COFFRET «MUST»

White cardboard drawer for «MUST» tray
Bandeja blanca para caja «MUST»

	380 x 290 x 30 mm	
	20PL395TIROIR	
	100 50	

Plateaux repas

Les  :

- Calage
- Transport optimisé

PLATEAU «MUST» AVEC CALAGE

Le plateau «MUST» version «Light» dispose d'une ergonomie et d'une résistance permettant un transport en toute sécurité des repas. D'un habillage blanc et sobre, ce plateau repas avec couvercle est personnalisable. Pratique, il dispose de différents compartiments prévus pour un repas complet.



Ce plateau ne contient pas de couverts

PLAQUE DÉCOUPÉE BLANCHE

White segmented plate - Plancha troquelada blanca



480 x 380 x 70 mm
20PL395PPT/C
100
50



BOL OREILLES PP BLANC

White PP bowl with handles - Bol con asas PP



350 cc
1430350N2
720 (12x60)
20



COUVERCLE PP TRANSPARENT POUR BOL OREILLES

PP transparent lid for white bowl with handles
Tapa PP transparente para bol con asas



1430350COUV
648
20



POT À SAUCE PS 3 cl

PS condiment container - Bote PS para salsa



3 cl - 1 oz
09POT100
5000 (20x250)
39



COUVERCLE PS TRANSPARENT

Transparent lid for condiment container
Tapa transparente para bote de salsa



3 cl
09POTL1/C
5000 (50x100)
50



BARQUETTE PP BLANC 250 gr

White PP container - Cesta PP blanca



137 x 95 x 30 mm
3140250
1800 (12x150)
28



BARQUETTE «SURF» PP BLANCHE

White «SURF» container - Recipiente blanco «SURF»



160 H 45
1210450
592
20



VERRE À PIED PS TRANSPARENT

Transparent PS stemmed glass
Copa PS transparente



17 cl
GK20
250 (25x10)
45



BARQUETTE PP 750 gr BLANCHE

White PP container - Cesta PP blanca



190 x 137 x 42 mm
3140750
800 (16x50)
28





Plateaux repas

ÉTUI «KRAFT BRUN»



ETUI KRAFT BRUN + CALAGE
Brown cardboard case
Estuche kraft marrón

 340 x 180 x 90 mm
 1200340
 50



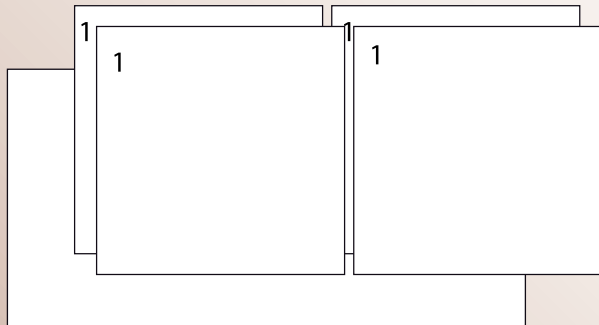

Nous vous proposons plusieurs compositions pour ce plateau...

Empilez quatre assiettes !

Collection « Esmeralda »







1 - ASSIETTE PS INJECTÉ VERT TRANSPARENT
TPS transparent green plate - Plato PS verde transparente

 160 x 160 x 20 mm
 11315016
 200
 56







1 bis - COUVERCLE PET TRANSPARENT
POUR ASSIETTE PS INJECTÉ 160 x 160
Transparent PET lid - Tapa PET verde transparente

 165 x 165 x 40 mm
 11315016COV
 200
 56







1 - ASSIETTE PULPE BLANCHE
Square cellulose plate - Plato pulpa cuadrado

 170 x 170 x 15 mm
 1152117
 300 [12x25]
 88



1 bis - COUVERCLE RPET TRANSPARENT
POUR ASSIETTE PULPE 170 x 170
RPET lid for cellulose plate - Tapa PET-R para plato pulpa

 180 x 180 x 40 mm
 1152117COV
 300 [6x50]
 16





Plateaux repas

COFFRET «KRAFT BRUN»



COFFRET KRAFT BRUN MICRO CANNELLÉ AVEC FENÊTRE
Brown ridged cardboard box with window
Caja cartón marrón microacanalado

 450 x 290 x 70 mm
 1201450
 50





Les  :

- Calage
- Modularité
- Fenêtre de visibilité



PLATEAU BOIS 280 x 420 MM
Wooden plate
Plato de madera rectangular

 280 x 420 mm
 BIO280420
 100



Variez les plaisirs avec les plateaux carton !



PLATEAU CARTON OR
Réf. 820101 / P.136
Gold Cardboard Tray
Meseta cartón de oro



PLATEAU CARTON ARGENT
Réf. 820106 / P.136
Silver cardboard tray
meseta cartón de plata



Collection «Wood Mood»





PLATEAU «LUXE» BOIS

PLATEAU «LUXE» BOIS
«LUXE» wooden tray - Bandeja «LUXE» madera

sur commande
to order/de encargo

 274x380 h30 mm
 BIO274380
 100 [2x50]

COUVERCLE
lid - Tapa



 -
 BIO274380COV
 50





RAVIER «LUXE» BOIS 215x85 MM

«LUXE» wooden dish - Pequeño plato «LUXE» madera

sur commande
to order/de encargo

 215x85 h28 mm
 BIO215085
 100

COUVERCLE lid - Tapa



 -
 BIO215085COV
 100





ASSIETTE «LUXE» BOIS 170x170 MM

«LUXE» wooden plate - Plato «LUXE» madera

sur commande
to order/de encargo

 170x170 h20 mm
 BIO170170
 100



COUVERCLE / lid / Tapa

 -
 BIO170170COV
 100





ASSIETTE «LUXE» BOIS 130x180 MM
«LUXE» wooden plate - Plato «LUXE» madera

sur commande
to order/de encargo

 130x180 h28 mm
 BIO130180
 100

COUVERCLE lid - Tapa



 -
 BIO130180COV
 100





RAVIER «LUXE» BOIS 155x85 MM

«LUXE» wooden dish - Plato «LUXE» madera

sur commande
to order/de encargo

 155x85 h28 mm
 BIO85155
 100

COUVERCLE / Lid / Tapa

 -
 BIO85155COV
 100



 Dimensions
Dimensions

 Capacité
Capacity

 Référence
Reference

 Conditionnement
Packaging

Plateaux repas

Collection «Non stop»

La Gamme «GOUTTE D'EAU» est destinée aux professionnels de la restauration rapide notamment à la recherche de vaisselle jetable pour préparations chaudes ou froides.

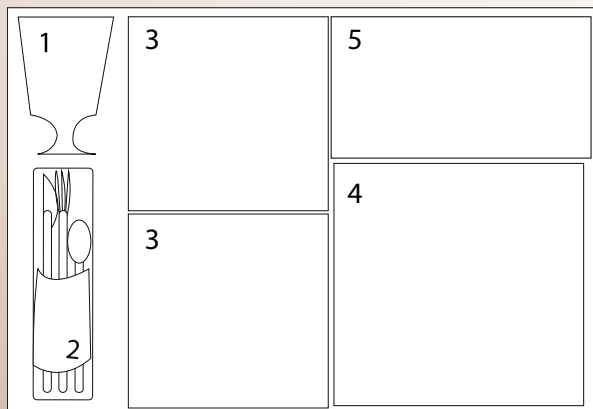
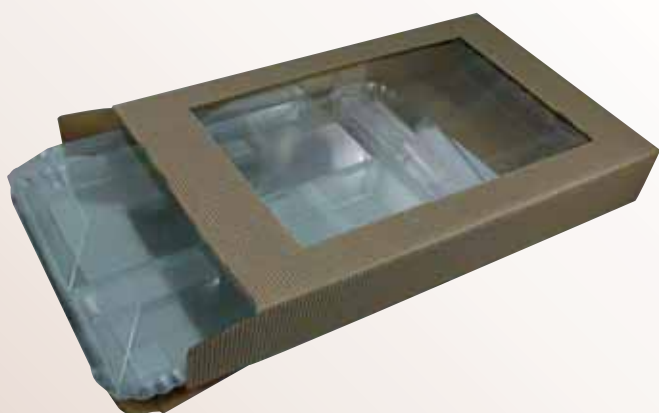

Les :

- Grand format
- Modularité
- Visibilité des produits



1 - VERRE À PIED PS TRANSPARENT

*PS transparent stemmed glass
Copa PS transparente*



17 cl
GK20
250
45



2 - SACHET COUVERTS PS TRANSPARENT 6 EN 1 (Couteau, Fourchette, Cuillère, Serviette, sel et poivre)

*6-In-1 PS pack of transparent cutlery
[fork + knife + spoon + serviette + salt & pepper]
Bolsita cubiertos PS transparentes 6 en 1 : tenedor,
cuchillo, cuchara de postre, servilleta, sal y pimienta*

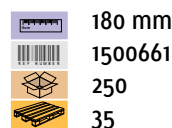

180 mm
1500661
250
35



3 - ASSIETTE PET VERT TRANSPARENT AVEC COUVERCLE PET VERT TRANSPARENT

*PET medium transparent green plate + lid
Plato medianoPET verde transparente + tapa*

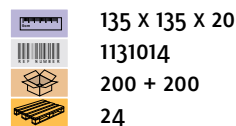

135 X 135 X 20
1131014
200 + 200
24



4 - ASSIETTE PET VERT TRANSPARENT AVEC COUVERCLE PET VERT TRANSPARENT

*PET large transparent green plate + lid
Plato grande PET verde transparente + tapa*

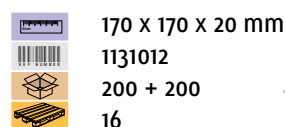

170 X 170 X 20 mm
1131012
200 + 200
16



5 - ASSIETTE PET VERT TRANSPARENT 170 X 100 AVEC COUVERCLE PET VERT TRANSPARENT

*PET rectangular transparent green plate w/ lid
Plato verde PET transparente + tapa*

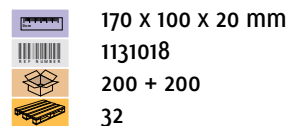

170 X 100 X 20 mm
1131018
200 + 200
32



Plateaux repas

Collection «Vision Verte»





Les  :

- Grand format
- Modularité
- Protection de l'environnement

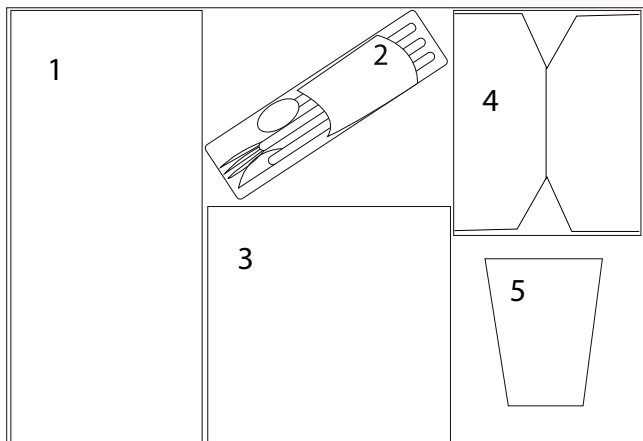
La Gamme «VISION VERTE» fabriquée à partir de pulpe de canne à sucre est idéale pour la vente à emporter. Ces contenants offrent de nombreux atouts : résistance et étanchéité aux sauces et aux graisses, micro-ondables jusqu'à 220 °C.







ASSIETTE BOIS 280 x 420
Wooden plate - Madera placa

 280 x 420 mm
 BIO280420
 100



1 - ASSIETTE PULPE BLANCHE

White cellulose plate - Plato pulpa blanco

 130 x 260 x 20 mm
 115211326
 300 (12x25)
 60







1 bis - COUVERCLE TRANSPARENT PET

POUR ASSIETTE PULPE BLANCHE 130 x 260 mm

PET transparent lid for cellulose plate

Tapa PET transparente para plato pulpa blanco

 145 x 275 mm
 115211326COV
 300 (6x50)
 16







2 - SACHET COUVERTS 3 EN 1 LUXE BIODÉGRADABLE

(Couteau+Fourchette+Serviette)

3-in-1 pack of Biodegradable Cutlery





Knife + Fork + Serviette)

 270 x 75 x 15 mm
 BIO1500630
 480
 40



3 - ASSIETTE PULPE BLANCHE





Square cellulose plate - Plato pulpa cuadrado

 170 x 170 x 15 mm
 1152117
 300 (12x25)
 88



3 bis - COUVERCLE TRANS. ASSIETTE PULPE 170 x 170

RPET Lid for cellulose plate - Tapa PET-R plato pulpa cuadrada

 180 x 180 x 40 mm
 1152117COV
 300 (6x50)
 16



4 - BOITE FIRPACK CARTON RECYCLÉ KRAFT BRUN

«FIRPACK» brown recycled cardboard box





Caja de cartón kraft reciclado «FIRPACK» marrón

 650 ml
 1330130
 450
 16



5 - GOBELET PULPE BLANC 26 cl

Cellulose Tumbler - Vaso de pulpa

 26 cl
 BIO826200
 750 (30x25)
 24



 Dimensions
Dimensions

 Capacité
Capacity

Plateaux repas

«LE SCCELLABLE»

Le plateau «THERMOSCELLABLE» est destiné aux collectivités. De part son ergonomie et ses 4 compartiments, il apporte une solution pratique de distribution des repas.

Notre Scelleuse La Scellinov



PLATEAU THERMOSCELLABLE GN_{1/2} PP BLANC

White PP heat-Sealable tray GN_{1/2}

Bandeja termosellable GN_{1/2} PP blanca



322,5 x 262,5 x 36 mm



EVM13458



200



16



FILM SOUDABLE PET 12-PP₃₀/PP

PET Tape for heat sealing 12-PP₃₀/PP

Film para sellar PET 12-P₃₀/PP



Existe en différentes laizes et longueurs



FR030



1



Les  :

- Ergonomique
- Pratique pour la distribution de repas
- Polypropylène
- Micro-ondable
- Thermoscellable



Plateaux repas

Les  :

- Composition ergonomique
- Hermétique
- Léger





PLATEAU «STANDARD»

Destiné aux collectivités, le plateau «STANDARD» dispose de 6 compartiments pour une séparation de chaque élément du repas. Grâce à son couvercle adapté, il est totalement hermétique (couvercle vendu séparément).



PLATEAU STANDARD PS BLANC





Standard white PS tray
Bandeja PS blanca estándar

 371 x 271 x 34 mm
 PR3727
 150 (6x25)
 32



COUVERCLE PS TRANSPARENT POUR PLATEAU STANDARD





Transparent lid for standard white PS tray
Tapa PS transparente para bandeja estándar

 371 x 271 x 34 mm
 PRC3727
 150
 24







Pour compléter ce plateau, nous vous proposons :

GOBELET PLASTIQUE PP TRANSPARENT 20/23 CL
Transparent PP plastic tumbler - Vaso PP

 20-23 cl
 8000223
 3000 (30x100)
 18



SACHET COUVERT 3/1 PLASTIQUE PS BLANC
3-In-1 PS pack o f white cutlery (fork + knife + serviette)
Bolsita cubiertos PS blancos 2 en 1: tenedor, cuchillo, servilleta

 170 x 250 mm
 1500630
 250
 49



 Dimensions
Dimensions

 Capacité
Capacity

 Référence
Reference

 Conditionnement
Packaging

Plateaux repas

Collection «Non stop»

Les  :

- Ergonomique
- Micro-ondable

PLATEAU «BARQUETTE»

Destiné aux traiteurs et professionnels de la restauration exigeante sur la qualité, le plateau «BARQUETTE» dispose de 2 compartiments pour présenter et transporter des plats cuisinés par exemple.



Ce plateau ne contient pas de couverts



Ce plateau ne contient pas de verre

PLATEAU BARQUETTE h35 PP BLANC

White PP Tray container h35
Bandeja doble alt. 35 blanca PP



227 x 177 x 35 mm
PR2CPA
400
20



COUVERCLE PP TRANSPARENT

POUR PLATEAU BARQUETTE h35 et h45

Transparent PP lid for white tray container h35, ht45
Tapa transparente PP alt.35, Alt. 45



227 x 177 x 45 mm
CO2CT
400
12



PLATEAU BARQUETTE h45 PP BLANC

White PP tray container h45
Bandeja doble alt. 45 blanca PP



227 x 177 x 45 mm
PR2CPAH45
400
16



Plateaux repas

Collection «Non stop»

Les  :

- Praticité pour le transport
- Personnalisable
- Emplacements pour 1 ou 2 bouteilles (33cl, 50cl, gobelet «Savane»)

BOÎTE SNACKING

La boîte de transport «Snacking» en carton comprend des poignées adaptées pour le portage de repas. Pratique, l'emplacement spécial boisson ou dessert permet de transporter votre repas en toute tranquillité (boîte livrée à plat pour gagner de la place).



Personnalisable !
Contactez notre service PAO :
pao@firplast.com



Ce plateau ne contient pas de couverts



Ce plateau ne contient pas de verre

PLATEAU SNACKING CARTON BLANC

White «SNACKING» cardboard take-away box

Caja blanca «SNACKING» cartón blanca



255 x 190 x 160 mm



0085559/C



140



20



Assiettes : Chez nous, la goutte d'eau ne fait jamais déborder le vase !

Collection «Non stop»

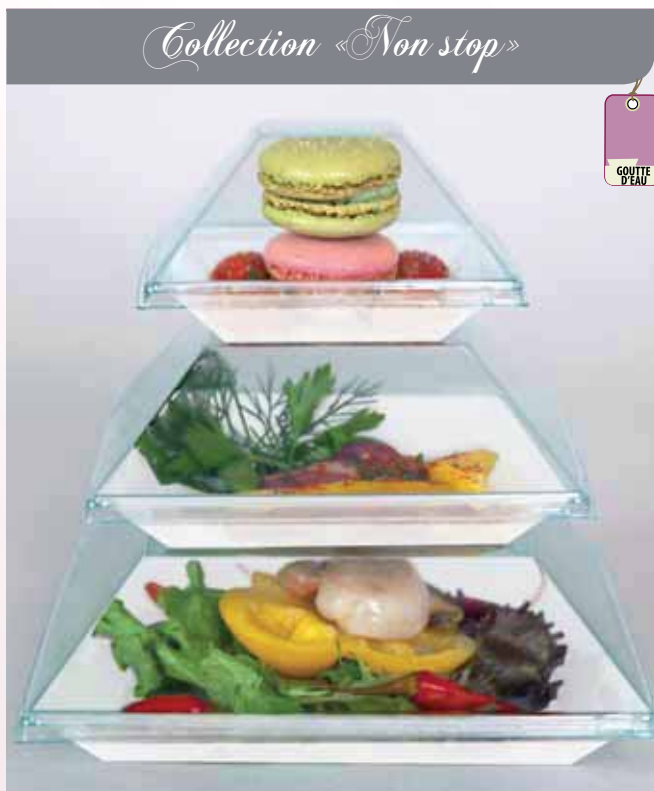

GRANDE ASSIETTE «GOUTTE D'EAU» PET + COUVERCLE
 PET large «GOUTTE D'EAU» plate + lid
 Plato grande «GOUTTE D'EAU» PET con tapa

170X170X20 mm
 1131012B
 200+200



MOYENNE ASSIETTE «GOUTTE D'EAU» PET + COUVERCLE
 PET medium «GOUTTE D'EAU» plate + lid
 Plato mediano «GOUTTE D'EAU» PET con tapa

135X135X20 mm
 1131014B
 200+200



ASSIETTE «GOUTTE D'EAU» PET RECTANGLE + COUVERCLE
 PET rectangular «GOUTTE D'EAU» plate + lid
 Plato rectangular «GOUTTE D'EAU» PET con tapa

170X100X20 mm
 1131018B
 200+200



RAVIER «GOUTTE D'EAU» PET + COUVERCLE
 PET «GOUTTE D'EAU» dish + lid
 Fuente «GOUTTE D'EAU» PET con tapa

100X100X20 mm
 1131013
 200+200



Pour présenter ces assiettes, nous vous proposons :

PLATEAU «FAMOUS BREAK» [Réf. 1201367] Page 60



Assiettes : Touché d'Émeraude, le Luxe par excellence !!

Collection « Esmeralda »



ASSIETTE PS «JADE» TRANSPARENT VERT ET COUVERCLE

«JADE» PS transparent Green Plate and Lid
Plato PS «JADE» verde transparente y tapa

assiette

160x160 mm
11315016
200

couvercle

-
11315016COV
200



ASSIETTE PS «JADE» TRANSPARENT VERT ET COUVERCLE

PS «JADE» transparent green plate and lid
Plato «JADE» PS verde transparente y tapa

assiette

130x130 mm
11315013
200

couvercle

-
11315013COV
200

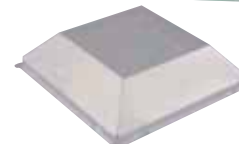

ASSIETTE PS «JADE» TRANSPARENT VERT ET COUVERCLE

PS «JADE» transparent green plate and lid
Plato «JADE» PS verde transparente y tapa

assiette

90x90 mm
11315009
200

couvercle

-
11315009COV
200



Pour présenter ces assiettes, nous vous proposons :

SACHET COUVERTS PS TRANSPARENT 6 EN 1

(Couteau, Fourchette, Cuillère, Serviette, sel et poivre)

6 -In-1 PS pack of transparent cutlery

(fork + knife + spoon + serviette + salt & pepper)

Bolsita PS cubiertos ps transparentes 6 en1: cuchillo + tenedor + cuchara de postre + servilleta + sal y pimienta

180 mm
1500661
250
35



VERRE À PIED PS TRANSPARENT

PS transparent stemmed glass

Copa PS transparente

17 cl
GK20
250 (25x10)
45



Assiettes : Soyez à la page !

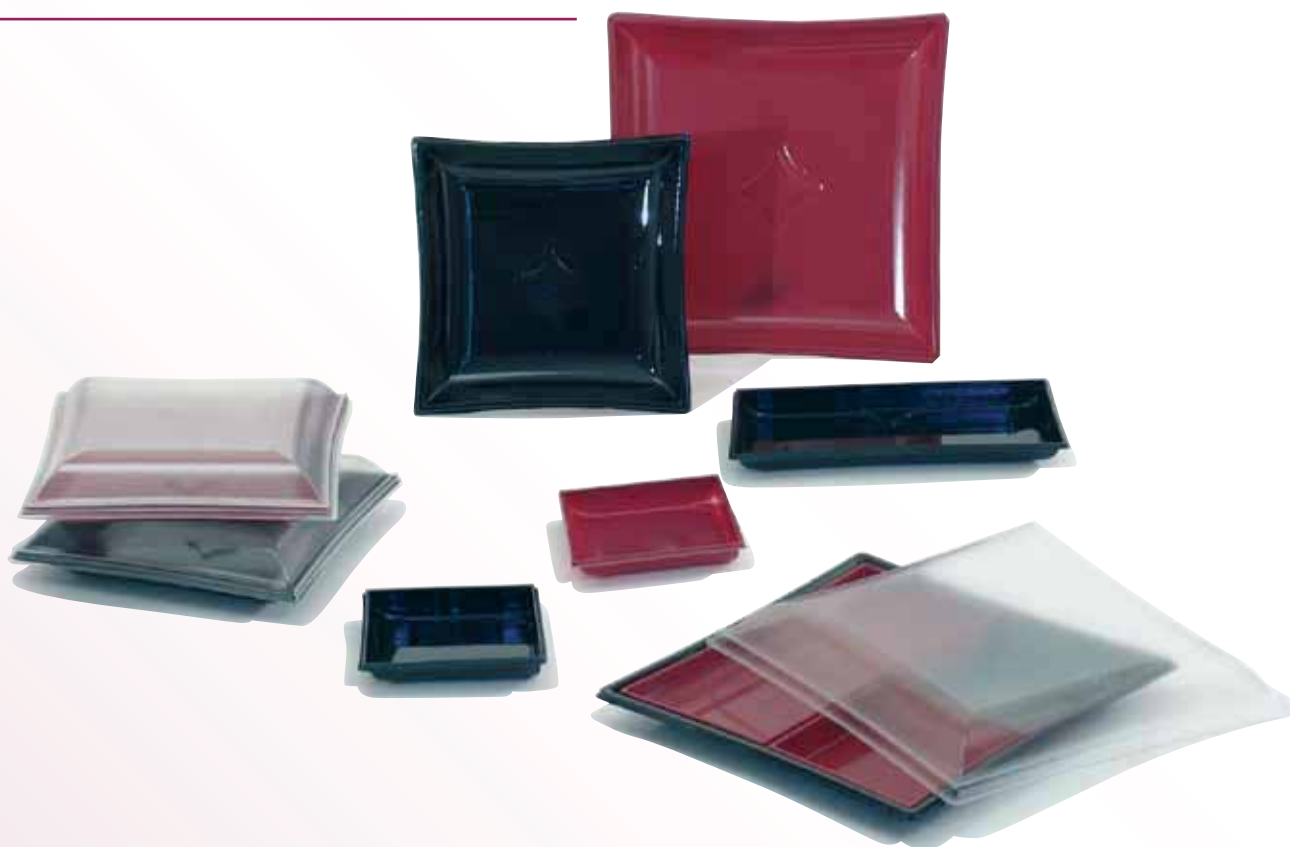

ASSIETTE «VAGUE» NOIRE 21x21 CM
Black «VAGUE» plate
Plato «VAGUE» negro





 210x210 mm
 1131002
 300 (3x100)

Retrouvez tous nos plateaux repas p.60

ASSIETTE «VAGUE» NOIRE 24,5x24,5 CM
Black «VAGUE» plate
Plato «VAGUE» negro



 245x245 mm
 1131009
 300 (3x100)



ASSIETTE «VAGUE» BORDEAUX 21x21 CM
Burgundy «VAGUE» Plate
Plato «VAGUE» burdeos



 210x210 mm
 1131006
 300 (3x100)

COUVERCLE PET TRANSPARENT «VAGUE» 24,5x24,5 CM
Transparent PET lid for «VAGUE» plate
Tapa transparente para plato «VAGUE»



 245x245 mm
 1131008
 300 (3x100)

COUVERCLE PET TRANSPARENT «VAGUE» 21x21 CM
Transparent PET Lid for «VAGUE» plate
Tapa PET transparente para plato «VAGUE»



 210x210 mm
 1131003
 300 (3x100)

Assiettes

Servez vos assiettes sur le plateau TOKUDAÏ !
p.83



PLATEAU «TOKUDAÏ» / Réf. 09153011
«TOKUDAÏ» tray
Bandeja «TOKUDAÏ»

GRANDE ASSIETTE «TOKUDAÏ» 145x275 mm AVEC COUVERCLE



Large «TOKUDAÏ» plate
Plato grande «TOKUDAÏ»

 145x275 mm
 113201427
 100



PETITE ASSIETTE «TOKUDAÏ» 135x145 mm AVEC COUVERCLE

Small «TOKUDAÏ» plate
Plato pequeño «TOKUDAÏ»

 135x145 mm
 113201314
 100





Idéal avec le plateau «OOKI» !





PLATEAU «OOKI» PS AVEC COUVERCLE APET
Réf. 09123827
«OOKI» tray
Bandeja «OOKI»

RAVIER «OOKI» PS 1/2 130x260 mm «OOKI» 1/2 Dish Ravier «OOKI» 1/2

 130x260 mm
 113211326
 50



RAVIER «OOKI» PS 1/4 130x130 mm «OOKI» 1/4 Dish Ravier «OOKI» 1/4

 130x130 mm
 113211313
 100





Assiettes

Collection « Esmeralda »



ASSIETTE CARREE TRANSPARENTE PS



PS transparent square plate
Plato cuadrado PS transparente

 110x110x20 mm
 11315011
 576 (48x12)



RAVIER CARRÉ TRANSPARENT PS



PS transparent square dish
Fuente cuadrada PS transparente

 110x110x40 mm
 12115011
 288 (12x24)



ASSIETTE CARRÉE CREUSE TRANSPARENTE PS



PS transparent square shallow bowl
Plato hondo PS transparente

 170x170x34 mm
 12115017
 192 (8x24)



ASSIETTE CARREE NOIRE PS

PS black square plate
Plato cuadrado PS negro

 220x220x20 mm
 11315422
 144 (12x12)



Assiettes

Fou des années 80 !



ASSIETTE «EIGHTIE» OCTOGONALE PS ROSE

*Pink octagonal «EIGHTIE» plate
Plato «EIGHTIE» octogonal rosa*

185 mm
 B1624
 400 (8x50)

240 mm
 B1603
 400 (8x50)



ASSIETTE «EIGHTIE» OCTOGONALE PS BLEUE

*Blue octagonal «EIGHTIE» plate
Plato «EIGHTIE» octogonal azul*

185 mm
 B1623
 400 (8x50)

240 mm
 B1602
 400 (8x50)



ASSIETTE «EIGHTIE» OCTOGONALE PS BLANCHE

*White octagonal «EIGHTIE» plate
Plato «EIGHTIE» octogonal blanco*

185 mm
 B1620
 400 (8x50)

240 mm
 B1600
 400 (8x50)



ASSIETTE «EIGHTIE» OCTOGONALE PS VERTE

*Green octagonal «EIGHTIE» plate
Plato «EIGHTIE» octogonal verde*

185 mm
 B1626
 400 (8x50)

240 mm
 B1606
 400 (8x50)



ASSIETTE «EIGHTIE» OCTOGONALE PS NOIRE

*Black octagonal «EIGHTIE» plate
Plato «EIGHTIE» octogonal negro*

185 mm
 B1621
 400 (8x50)

240 mm
 B1601
 400 (8x50)



ASSIETTE «EIGHTIE» OCTOGONALE PS BORDEAUX

*Burgundy octagonal «EIGHTIE» plate
Plato «EIGHTIE» octogonal burdeos*

185 mm
 B1629
 400 (8x50)

240 mm
 B1609
 400 (8x50)



ASSIETTE «EIGHTIE» OCTOGONALE PS JAUNE

*Yellow octagonal «EIGHTIE» plate
Plato «EIGHTIE» octogonal amarillo*

185 mm
 B1625
 400 (8x50)

240 mm
 B1605
 400 (8x50)



COUVERCLE PS TRANSPARENT POUR ASSIETTE «EIGHTIE»

*Transparent Lid for octagonal «EIGHTIE» plate
Tapa «EIGHTIE» transparente para plato octogonal*

185 mm
 B1631
 400 (8x50)

240 mm
 B1611
 400 (8x50)



Dimensions
Dimensions

Capacité
Capacity

Référence
Reference

Conditionnement
Packaging

Assiettes

Collection «Wood Mood»



ASSIETTE BOIS (PEUPLIER) RONDE Ø 150 mm

Round wooden plate
Plato de madera redondo

155x10 mm
BIO116155/C
1200 [25x48]



ASSIETTE HEXAGONALE BOIS (PEUPLIER) Ø 260 mm

Hexagonal wooden plate ø 10,2 inch
Plato de madera hexagonal

Ø 260 mm
BIO116260
250



ASSIETTE BOIS (PEUPLIER) RONDE Ø 190 mm

Round wooden plate
Plato de madera redondo

190x15 mm
BIO116190/C1
600 [6x100]



ASSIETTE RECTANGULAIRE BOIS (PEUPLIER)

Rectangular wooden plate
Plato de madera rectangular

195x140x30 mm
BIO330195/C
600 [6x100]



ASSIETTE BOIS (PEUPLIER) RONDE Ø 215 mm

Round wooden plate
Plato de madera redondo

215x15 mm
BIO116215/C
600 [6x100]



PLATEAU RECTANGULAIRE BOIS (PEUPLIER)

Rectangular wooden plate
Bandeja madera rectangular

265x215x20 mm
BIO330265/C
250





Assiettes

Collection «Wood Mood»





ASSIETTE «LUXE» BOIS 130x180 MM

«LUXE» wooden small dish - Plato «Luxe» madera y tapa

 130x180 h28 mm
 BIO130180
 100

COUVERCLE / lid / Tapa



 -
 BIO130180COV
 100





sur commande
to order / de encargo

ASSIETTE «LUXE» BOIS 170x170 MM

«EIGHTIE» wooden plate - Plato «Luxe» madera y tapa

 170x170 h20 mm
 BIO170170
 100

COUVERCLE / lid / Tapa



 -
 BIO170170COV
 100





sur commande
to order / de encargo

RAVIER «LUXE» BOIS 215x85 MM

«EIGHTIE» wooden small dish - Plato «Luxe» madera y

 215x85 h28 mm
 BIO215085
 100

COUVERCLE / lid / Tapa



 -
 BIO215085COV
 100





sur commande
to order / de encargo

RAVIER «LUXE» BOIS 155x85 MM

«EIGHTIE» wooden plate - Plato «Luxe» madera y tapa

 155x85 h28 mm
 BIO85155
 100

COUVERCLE / lid / Tapa

 -
 BIO85155COV
 100



sur commande
to order / de encargo

Retrouvez tous nos plateaux repas p.60
et nos couverts «Wood Mood» p.117



Couverts «BOIS»
Wooden cutlery
Cubiertos de madera



 Dimensions
Dimensions

 Capacité
Capacity

 Référence
Reference

 Conditionnement
Packaging

Assiettes : Solutions durables

Collection «Vision Verte»



ASSIETTE PULPE CARREE 170 mm / COUVERCLE RPET (PET RECYCLÉ)

Square cellulose plate and RPET lid
Plato pulpa cuadrado/tapa PET reciclado

170x170 mm
1152117
300 (12x25)
25



180x180 mm
1152117COV
300 (6x50)
-



ASSIETTE PULPE RECTANGLE / COUVERCLE RPET (PET RECYCLÉ)

Rectangular cellulose plate and RPET lid
Plato pulpa rectangular/tapa PET reciclado

130x260 mm
115211326
300 (12x25)
25



145x275 mm
115211326COV
300 (6x50)
-



ASSIETTE PULPE CARREE 210 mm / COUVERCLE RPET (PET RECYCLÉ)

Square cellulose plate 21cm and RPET lid
Plato pulpa cuadrado 21cm/tapa PET reciclado

210x210 mm
1152121
300 (12x25)
25



210x210 mm
1152121COV
300 (6x50)
-



Barquette «Vision Verte»



BARQUETTE PULPE + COUVERCLE

Sugar cane pulp container with lid
Plato cuadrada pulpa y tapa

200x145x80 mm
32402015
500
21



ASSIETTE PULPE CARREE 250 mm

Square cellulose plate
Plato pulpa cuadrado

250x250 mm
1152125
300 (12x25)
25



Assiettes

Collection «Vision Verte»



Couvercle pratique !



ASSIETTE PULPE RONDE Ø 170 mm

Round Cellulose Plate
Plato pulpa redondo

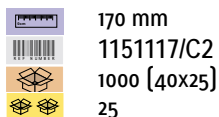

170 mm
1151117/C2
1000 [40x25]
25



ASSIETTE PULPE RONDE 3 COMPARTIMENTS Ø 260 mm

Round sugar cane pulp plate 3 compartments
Plato pulpa redondo 3 compartimentos

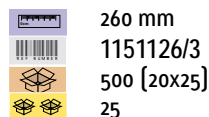

260 mm
1151126/3
500 [20x25]
25



ASSIETTE PULPE RONDE Ø 228,6 mm

Round Cellulose Plate
Plato pulpa redondo

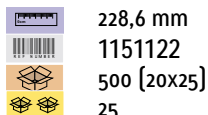

228,6 mm
1151122
500 [20x25]
25



ASSIETTE PULPE OVALE GRANDE

Large White oval cellulose plate
Plato pulpa ovalado grande

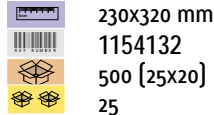

230x320 mm
1154132
500 [25x20]
25



ASSIETTE PULPE RONDE Ø 260 mm

Round Cellulose Plate
Plato pulpa redondo

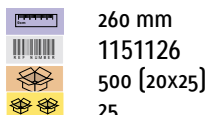

260 mm
1151126
500 [20x25]
25



ASSIETTE PULPE OVALE MOYENNE

Medium white oval cellulose plate
Plato pulpa ovalado mediano

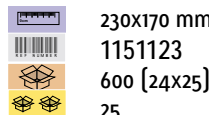

230x170 mm
1151123
600 [24x25]
25



Retrouvez le mini-pot p.109



MINI POT EN PULPE 57 ML /Réf. 145105
Sugar cane pulp mini arton
Mini Pulp pot



Retrouvez toute notre collection «Vision Verte»
sur le site www.visoin-verte.com

Assiettes : Envie de folies ?

Variez les plaisirs avec nos assiettes cocktails...

ASSIETTE «COCKTAIL» + EMPLACEMENT VERRE OU FLÛTE



«COCKTAIL» plate with glass holder
Plato «COCKTAIL» con portava

 200x200 mm
 1131020
 200 (10x20)



ASSIETTE «COCKTAIL» RONDE NOIRE

«COCKTAIL» black round plate
Plato «COCKTAIL» redondo negro
Couleur à partir de 3000 ex.

 Ø 245 mm
 1334025
 48





Collection «Vision Verte»



ASSIETTE «COCKTAIL» PULPE CARRÉE + EMPLACEMENT VERRE OU FLÛTE



«COCKTAIL» square cellulose plate
Plato «COCKTAIL» cuadrado en pulpa

 210x210 mm
 1155121
 300 (12x25)



ASSIETTE «COCKTAIL» PULPE CARRÉE + EMPLACEMENT VERRE OU FLÛTE

«COCKTAIL» square cellulose plate
Plato «COCKTAIL» cuadrado en pulpa

 250x250 mm
 1155125
 300 (12x25)



Retrouvez toute notre collection «Vision Verte»
sur le site www.visoin-verte.com

Saladiers et mini-pots



SALADIER ROND PET 24 CL - 8 OZ

Round PET salad bowl
Ensaladera redonda PET



24 cl - 8 oz
146008
500 (20x25)



SALADIER ROND PET 34 CL - 12 OZ

Round PET salad bowl
Ensaladera redonda PET



34 cl - 12 oz
146012
500 (20x25)



SALADIER ROND PET 45 CL - 16 OZ

Round PET salad bowl
Ensaladera redonda PET



45 cl - 16 oz
146016
500 (20x25)



SALADIER ROND PET 68 CL - 24 OZ

PET round salad bowl
Ensaladera redonda PET



68 cl - 24 oz
146024
500 (20x25)



COUVERCLE PET POUR SALADIER 146008, 146012, 146016, 146024

Lid for round PET salad bowl
Tapa para ensaladera redonda PET



-
146000
500 (20x25)



SALADIER ROND PET 90 CL - 32 OZ

Round PET salad bowl
Ensaladera redonda PET



90 cl - 32 oz
DM32
500 (20x25)



COUVERCLE PET POUR SALADIER DM32

Lid for round PET salad bowl
Tapa para ensaladera redonda PET



-
LG8
500 (20x25)



Saladiers et mini-pots : Envoie de fraîcheur ?

GAMME SHINJUKU

GAMME SHINJUKU

SALADA



Ces saladiers ne contiennent pas de verre



Ces saladiers ne contiennent pas de couverts



GRANDE FAIM

SALADIER «SALADA» APET

«SALADA» salad bowl
Ensaladera «SALADA»

205x205 mm
11350205
100



PETITE FAIM

SALADIER «LUXE» TRANSPARENT PS

«LUXE» transparent salad bowl
Ensaladera «LUXE» transparente

base 100x100 mm
1412050
144 (12x12)



ASSIETTE «SALADA» APET + COUVERCLE APET

«SALADA» plate
Plato «SALADA»

135x145 mm
113201314
100



COUVERCLE APET POUR SALADIER «SALADA»

Cover for «SALADA» salad bowl
Tapa para ensaladera «SALADA»

205x205 mm
11350205COV
100



«Grande faim» ou «Petite faim»,
vous n'arrivez pas à choisir ?
Optez pour le saladier «Vague» !

SALADIER «VAGUE» PS FOND TRANSPARENT + COUVERCLE

«VAGUE» salad bowl + transparent base + lid
Ensaladera «VAGUE» base transparente + tapa

175x175 mm
1131015
200 saladiers
+ 200 couvercles



Saladiers et mini-pots

SALADIER «CLASSIQUE» PET NOIR Ø 180 MM

PET «CLASSIC» black salad bowl
Ensaladera PET negra «CLASSIC»

sur commande
to order / de encargo

Ø 180 mm
750/950 ml
9825375
200 [4x50]



SALADIER «CLASSIQUE CRISTAL» PET Ø 180 MM - H 70 MM

PET «CLASSIC CRISTAL» salad bowl
Ensaladera «CLASSIC CRISTAL» PET

Ø 180 mm - H 70 mm
750 ml
9825677/C
200 [4x50]



SALADIER «CLASSIQUE» PET NOIR Ø 260 MM

PET «CLASSIC» black salad bowl
Ensaladera PET negra «CLASSIC»

Ø 240 mm
1500 ml
9825322
100



SALADIER «CLASSIQUE CRISTAL» PET Ø 162 MM - H 56 MM

PET «CLASSIC CRISTAL» salad bowl
Ensaladera «CLASSIC CRISTAL» PET

Ø 162 mm - H 56 mm
1000 ml
9825675/C1
200 [4x50]



SALADIER «CLASSIQUE» PET NOIR Ø 310 MM

PET «CLASSIC» black salad bowl
Ensaladera PET negra «CLASSIC»

Ø 310 mm
4500 ml
9825345/C
50



SALADIER «CLASSIQUE CRISTAL» PET Ø 223 MM - H 91 MM

PET «CLASSIC CRISTAL» salad bowl
Ensaladera «CLASSIC CRISTAL» PET

Ø 260 mm - H 91 mm
2400 ml
9825622
120 [1x120]



COUVERCLE «DÔME» PET POUR SALADIER «CLASSIQUE NOIR ET CRISTAL»

PET Lid for black and «CRISTAL» salad bowls
Tapa para ensaladera PET negra y «CRISTAL»

Ø 180 mm
9655411/C1
200



Ø 260 mm
9655440
120



Ø 310 mm
9655450/C
50



SALADIER «CLASSIQUE CRISTAL» PET Ø 310 MM

PET «CLASSIC CRISTAL» salad bowl
Ensaladera «CLASSIC CRISTAL» PET

Ø 310 mm
4500 ml
9825645/C
50





Saladiers et mini-pots



BOCAL «TERROIR» PLASTIQUE 125 ml

«TERROIR» container
Bocal «TERROIR»

 125 ml
 8470125
 84



BOCAL «TERROIR» PLASTIQUE 200 ml

«TERROIR» container
Bocal «TERROIR»

 200 ml
 8470200
 56



BOCAL «TERROIR» PLASTIQUE 300 ml

«TERROIR» container
Bocal «TERROIR»

 300 ml
 8470300
 60



BOCAL «TERROIR» PLASTIQUE 350 ml

«TERROIR» container
Bocal «TERROIR»

 350 ml
 8470350
 48



Saladiers et mini-pots



Collection «Vision Verte»



BOL PULPE ROND 680 ml

Round cellulose bowl
Cuenco pulpa redondo

680 ml
 145168/C
 500 (20x25)



COUVERCLE

Cover / Tapa

-
 145168COV
 500 (10x50)



BOL PULPE ROND 300 ml

Round cellulose bowl
Cuenco pulpa redondo

300 ml
 145130/C
 1800 (25x72)



BOL PULPE CARRÉ 250 ml

Square cellulose bowl
Cuenco pulpa cuadrado

250 ml / 15 oz
 145115
 300 (12x25)



MINI-POT «CRISTAL» PLA

«CRISTAL» mini-bowl - minibote «CRISTAL»

60 ml
 BIO1360
 2000 (20x100)

80 ml
 BIO1380
 2000 (20x100)

COUVERCLE PLA

Cover / Tapa

-
 BIO13COV
 2000 (20x100)



SALADIER PULPE 800 ml

Cellulose salad bowl
Ensaladera pulpa

800 ml
 186x143x80 mm
 14511500
 [25x25]



POT PULPE 425 ml

Cellulose bowl
Tapa pulpa

425 ml / 15 oz
 145400
 1000 (40x25)



COUVERCLE PULPE

Lid for cellulose bowl

Tapa pulpa

-
 145400COV
 1000 (40x25)



MINI POT EN PULPE 57 ml

Cellulose mini-bowl
Minibote pulpa

57 ml - 2oz
 145105
 2000 (80x25)



POT PULPE 140 ml

Cellulose bowl
Bote de pulpa

140 ml / 5 oz
 BIO826140
 1000 (40x25)



GOBELET PULPE 260 ml

Cellulose bowl
Bote de pulpa

260 ml / 9 oz
 BIO826200
 750 (30x25)



Saladiers et mini-pots

BOITE SUSHI + COUVERCLE T. 1 PS

Sushi box size 1
Bandeja sushi medida 1



Boite

171x91x20 mm
3050010
600 (12x50)

Couvercle

176x96x30 mm
3050010COV
600 (12x50)

POT ROND PLA 12OZ/300 ml

Round PLA container
Bote redondo PLA



12oz - 300 ml
BIO146012/C
500 (10x50)

BOITE SUSHI + COUVERCLE T. 2 PS

Sushi box size 2
Bandeja sushi medida 2



Boite

166x115x20 mm
3050020/C
300 (6x50)

Couvercle

171x120x30 mm
3050020COV/C
300 (6x50)

POT ROND PLA 16OZ/ 400 ml

Round PLA container
Bote redondo PLA



16oz - 400 ml
BIO146016/C
500 (10x50)

BOITE SUSHI + COUVERCLE T. 3 PS

Sushi box size 3
Bandeja sushi medida 3



Boite

185x129x20 mm
3050030/C
450 (9x50)

Couvercle

190x134x30 mm
3050030COV/C
450 (9x50)

POT ROND PLA 24OZ/600 ml

Round PLA container
Bote redondo PLA



24oz - 600 ml
BIO146024/C
500 (10x50)

BOITE SUSHI + COUVERCLE T. 4 PS

Sushi box size 4
Bandeja sushi medida 4



Boite

215x135x20 mm
3050040/C
400 (8x50)

Couvercle

220x140x30 mm
3050040COV/C
400 (8x50)

COUVERCLE PLA POUR POTS RONDS PLA 12/16/24 OZ

PLA Lid for round PLA containers
Tapa PLA para botes redondos PLA



Diam. 102 mm
BIO146000COV
500 (10x50)



Coupes desserts

COUPE À DESSERT PLA BLANC TRANSPARENT 8 CL

Transparent white PLA dessert cup
Copa de postre PLA blanca



8 cl
BIO14080
1200 (12x100)



sur commande
to order/ de encargo

COUPE À DESSERT PLA BLANC TRANSPARENT 21 CL

Transparent white PLA dessert cup
Copa de postre PLA blanca



21 cl
BIO14170
800 (8x100)



sur commande
to order/ de encargo

Pour compléter ces coupes,
nous vous proposons
les accessoires suivants :

CUILLÈRE DESSERT
COULEURS VERT ET BLANC
(Réf. BIO15095) Page 121



COUPE À DESSERT PP 15 CL

PP dessert cup
Copa de postre PP



15 CL
GK1331PP
600 (24x25)



COUVERCLE

Cover - Tapa



-
MK1619
600 (12x50)



COUPE À DESSERT «CRISTAL» APET 25/30 CL

APET «CRISTAL» dessert cup
Copa de postre «CRISTAL» APET



25/30 cl
8240105
600 (20x30)



COUVERCLE PLAT

Cover - Tapa



-
8080105
600 (20x30)



Dimensions
Dimensions

Capacité
Capacity

Référence
Reference

Conditionnement
Packaging

Coupes desserts

COUPE À DESSERT «ESMERALDA» VIOLETTE

«ESMERALDA» purple dessert cup
Copa de postre «ESMERALDA» lila



20 cl
600021R
1000



COUPE «LUXE» PS

«LUXE» PS cup
Copa de postre «LUXE» PS



30 cl
1410030
200 (20x10)



COUPE A DESSERT PET 7 OZ / 20 CL

PET dessert cup
Copa de postre PET



20 cl - 7 oz
8240007
1000 (20x50)



COUPE À DESSERT PET 9 OZ / 27 CL

PET dessert cup
Copa de postre PET



27 cl - 9 OZ
8240009
1000 (20x50)



COUVERCLE PLAT SANS TROU POUR COUPE

8240009 / 8240007

Cover for cups 8240009 / 8240007
Tapa para copa 8240009 / 8240007



-
8084009
1000 (10x100)



Retrouvez nos autres solutions desserts avec nos verrines p.26



Cuillère «TAPAS»
Voir page 27



Verrine «VENISE»
Voir page 26



Verrine «SPHÈRE» 20 cl
Voir page 36



Bocaux «TERROIR»
4,5 cl / 8 cl / 30 cl
Voir page 30

CUILLÈRE À GLACE EMBALLÉE
(Réf. 600023) Page 121

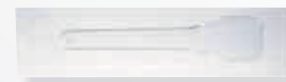

SACHET COUVERTS : CUILLÈRE TRANSPARENTE 125 MM
(Réf. 1500610T) Page 121



Pour compléter ces coupes,
nous vous proposons
les accessoires suivants :

Couverts, sachets couverts et accessoires

Collection «Wood Mood»



SACHET 3/1 BOIS (COUPEAU + FOURCHETTE + CUIILLÈRE)

3-in-1 pack of wooden cutlery (fork + knife + spoon)
Bolsita de cubiertos 3 en 1 madera (cuchillo + tenedor + cuchara)

165 mm
1590630
250



Collection «Frenchy foliess»

KIT 4/1 INOX RÉUTILISABLE (FOURCHETTE + COUPEAU + CUIILLÈRE + SERVIETTE)

4-in-1 pack of reusable stainless cutlery (fork + knife + spoon + serviette)
Kit réutilizable cubiertos de acero inoxidable 4 en 1 (cuchillo + cuchara + servilleta tenedor + cuchillo + cuchara + servilleta)

0093119
100



Collection «Vision Verte»



SACHET 3/1 PULPE (COUPEAU + FOURCHETTE + SERVIETTE)

3-In-1 pack of cellulose cutlery (fork + knife + serviette)
Bolsa de cubiertos de madera (cuchillo + tenedor + servilleta)

270x75x15 mm
BIO1500630
480



Collection «Esmeralda»

SACHET 6/1 «LUXE» TRANSPARENT (FOURCHETTE PS+ COUPEAU PS+ PETITE CUIILLÈRE PS+ SERVIETTE + POIVRE & SEL)

«LUXE» 6-in-1 pack of transparent cutlery (fork + knife + dessert spoon + serviette + salt & pepper)
Bolsita cubiertos transparentes 6 en 1 (tenedor + cuchillo + cuchara de postre + servilleta + sal y pimienta)

1500661
250



SACHET 4/1 BLANC (FOURCHETTE + COUPEAU + PETITE CUIILLÈRE + SERVIETTE)

4-In-1 pack of white cutlery (fork + knife + dessert spoon + serviette)
Bolsita cubiertos blancos 4 en 1 (tenedor + cuchillo + cuchara de postre + servilleta)

1500640
250



SACHET 6/1 BLANC (FOURCHETTE PS + COUPEAU PS + PETITE CUIILLÈRE PS + SERVIETTE + POIVRE & SEL)

6-In-1 pack of white cutlery (fork + knife + dessert spoon + serviette + salt & pepper)
Bolsita cubiertos blancos 6 en 1 (tenedor + cuchillo + cuchara de postre + servilleta + sal y pimienta)

1500660
250



Couverts, sachets couverts et accessoires

Collection «Frenchy foliess»

FOURCHETTE «COCKTAIL» INOX

Stainless «COCKTAIL» fork
Tenedor «COCKTAIL» acero inoxidable

réutilisable



120 mm
000004710201
12



CUILLÈRE «COCKTAIL» INOX AVEC CROCHET

Stainless «COCKTAIL» spoon with hook
Cuchara «COCKTAIL» acero inoxidable con gancho

réutilisable



120 mm
000004710806
12



CUILLÈRE COUDÉE «PARTY» INOX

Stainless wave «PARTY» spoon
Cuchara acero inoxidable «PARTY»

réutilisable



100 mm
000004710202
12



ETUI COUVERT BRUN «BON APPÉTIT» + SERVIETTE PASTEL

Brown «BON APPÉTIT» cutlery case + pastel serviette
Estuche para cubiertos «BON APPÉTIT» marrón + servilleta pastel



200x85 mm
0900302
600

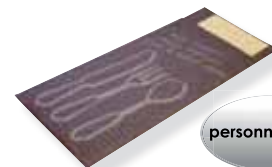

personnalisable

Retrouvez tous nos sachets couverts p.113

KIT COUVERTS INOX RÉUTILISABLE
(FOURCHETTE + COUTEAU + CUILLÈRE + SERVIETTE)

Réf. 0093119

Pack of reusable stainless cutlery

[fork, knife, spoon, serviette]

kit cubiertos de acero inoxidable

[tenedor + cuchillo + cuchara + servilleta]





Couverts, sachets couverts et accessoires

Collection « Esmeralda »

FOURCHETTE TRANSPARENTE «GIVRÉE» PS



PS «GIVRÉE» transparent fork
Tenedor «GIVRÉE» PS transparente

 180 mm
 1513318
 250 (10x25)



COUTEAU TRANSPARENT «GIVRÉ» PS



PS «GIVRÉ» transparent knife
Cuchillo «GIVRÉ» PS transparente

 190 mm
 1523319
 250 (10x25)



CUILLÈRE TRANSPARENTE «GIVRÉE» PS



PS «GIVRÉE» transparent spoon
Cuchara «GIVRÉE» PS transparente

 170 mm
 1533318
 250 (10x25)



FOURCHETTE ARGENT PS

PS silver fork
Tenedor PS plateado

 188 mm
 1513419
 1000 (50x20)



COUTEAU ARGENT PS



PS silver knife
Cuchillo PS plateado

 200 mm
 1523420
 1000 (50x20)



CUILLÈRE DESSERT ARGENT PS

PS silver dessert spoon
Cuchara PS plateada

 130 mm
 1533413
 1000 (50x20)



Pour compléter nos verrines nous vous proposons les couverts suivants :



FOURCHETTE «COCKTAIL ARGENT» PS

PS transparent «COCKTAIL» fork
Minitenedor plateado «COCKTAIL» PS

 100 mm
 1513104
 1920 (48x40)



CUILLÈRE «COCKTAIL ARGENT» PS

PS transparent «COCKTAIL» spoon
Minicuchara plateada «COCKTAIL» PS

 100 mm
 1543104
 1920 (48x40)



Couverts, sachets couverts et accessoires



ETUI COUVERT BRUN «BON APPÉTIT» + SERVIETTE PASTEL
Brown «BON APPÉTIT» cutlery case w/ pastel serviette
Estuche marrón para cubiertos «BON APPÉTIT» +servilleta

200x85 mm
 0900302
 600



**Votre logo sur les étuis ?
 C'est possible, contactez notre
 service pao pour une solution
 personnalisée :**
pao@firplast.com

Exemples de personnalisation
Examples of customisation - Ejemplos de personalización

SEL & POIVRE
Salt & pepper
Sal y pimienta

sur commande
to order/à la commande

DUO/C
 220



RINCE-DOIGTS
Finger wipes
Toallita limpiadora

10001
 1000



PIPETTE À SAUCE
Pipette for sauce
Pipeta para salsa

4 ml
 00000000PS01
 12

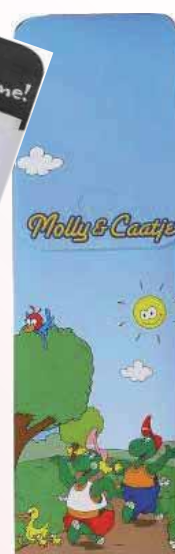



Couverts, sachets couverts et accessoires

Collection «Wood Mood»



FOURCHETTE AMIDON DE MAÏS



Corn starch fork
Tenedor almidón de maíz

 165 mm
 BIO1511170/C
 1000 (10x100)



FOURCHETTE BOIS



Wooden fork
Tenedor de madera

 165 mm
 1591119
 2000 (20x100)



COUTEAU AMIDON DE MAÏS



Corn starch knife
Cuchillo almidón de maíz

 165 mm
 BIO1521170/C
 1000 (10x100)



COUTEAU BOIS



Wooden knife
Cuchillo de madera

 165 mm
 1591219
 2000 (20x100)



CUILLERE AMIDON DE MAÏS



Corn starch spoon
Cuchara almidón de maíz

 160 mm
 BIO1531170/C
 1000 (10x100)



CUILLERE A SOUPE BOIS



Wooden soup spoon
Cuchara de madera

 165 mm
 1591319
 2000 (20x100)



CUILLERE À DESSERT BOIS



Wooden dessert spoon
Cuchara de postre madera

 140 mm
 1591125/C
 2000 (20x100)



CUILLERE À CAFE BOIS

Wooden coffee spoon
Cucharilla de café madera

 110 mm
 1591110/C
 2000



**Pour compléter cette gamme,
nous vous proposons
le sachet couvert :**

SACHET 3/1 BIODÉGRADABLE
(COUTEAU + FOURCHETTE + SERVIETTE)
(Réf. BIO1500630) Page 113



**Pour compléter cette gamme,
nous vous proposons
le sachet couvert :**

SACHET 3/1 BOIS (COUTEAU + FOURCHETTE + CUILLÈRE)
(Réf. 1590630) Page 113



Couverts, sachets couverts et accessoires

FOURCHETTE PS TRANSPARENT

PS transparent fork
Tenedor PS transparente



190 mm



1523190T



1000 (10x100)



COUTEAU PS TRANSPARENT

PS transparent knife
Cuchillo PS transparente



190 mm



1513190T



1000 (10x100)



CUILLÈRE ENTREMENT PS TRANSPARENT

PS transparent spoon
Cuchara PS transparente



144 mm



1533190T



1000 (10x100)



CUILLÈRE À DESSERT PS TRANSPARENT

PS transparent dessert spoon
Cuchara de postre PS transparente



125 mm



1541125T



2000 (20x100)



FOURCHETTE PS NOIR

PS black fork
Tenedor PS negro



190 mm



1523190N/C



1000 (10x100)



COUTEAU PS NOIR

PS black knife
Cuchillo PS negro



190 mm



1513190NC



1000 (10x100)



Pour compléter nos verrines éphémères, nous vous proposons les couverts suivants :



FOURCHETTE «COCKTAIL» PS TRANSPARENT

PS transparent cocktail fork
Minitenedor PS transparente



100 mm



1513103



1000 (25x40)



CUILLÈRE «COCKTAIL» PS TRANSPARENT

PS transparent cocktail spoon
Minichuchara PS transparente



100 mm



1543103



1000 (25x40)



CUILLÈRE À DESSERT PS NOIR

PS black dessert spoon
Cuchara de postre PS negra



125 mm



1543125N



1500 (3x500)



Couverts, sachets couverts et accessoires

Collection «Wood Mood»



PIQUE DRAPEAU BAMBOU

Bamboo flag appetiser pick
Palillo extremo plano bambú



	105 mm
	158105
	2000 (20x100)
	150 mm
	158150
	2000 (20x100)
	180 mm
	158180
	2000 (20x100)



PIQUE NOEUD BAMBOU

Bamboo knot appetiser pick
Palillo nudo bambú

	70 mm
	1580070
	2000 (20x100)
	100 mm
	1580105
	2000 (20x100)
	180 mm
	1580180
	2000 (20x100)



PINCE BAMBOU 90 mm

Bamboo tongs
Pinza bambú

	90 mm
	1581090
	2000 (20x100)



PINCE BAMBOU 150 mm

Bamboo tongs
Pinza bambú

sur commande
to order / de encargo

	150 mm
	1581150
	200



PIQUE BAMBOU FOURCHETTE

Bamboo cocktail fork
Palillo con tenedor bambú

	90 mm
	1580170
	2000



PIC SUR PIED BAMBOU

Bamboo skewer with stand
Pincho con base bambú

	90 mm
	1580006
	240 (10x24)



FOURCHETTE BAMBOU

Bamboo fork
Tenedor bambú

	90 mm
	1591190
	480 (20x24)



CUILLÈRE BAMBOU

Bamboo spoon
Cuchara bambú

	90 mm
	1591390
	480 (20x24)



Dimensions
Dimensions

Capacité
Capacity

Référence
Reference

Conditionnement
Packaging

Couverts, sachets couverts et accessoires

Collection «Wood Mood»



PIQUE «COCKTAIL» BOIS
Wooden «COCKTAIL» pick
Palillo «COCKTAIL» madera

 80 mm
 WT108
 1000





PIQUE «COCKTAIL» 2 POINTES BOIS
Wooden «COCKTAIL» pick
Palillo «COCKTAIL» madera

 68 mm
 WT106
 1000





AGITATEUR CAFE BOIS 140 MM
Wooden coffee stirrer
Removedor para café madera

 140x5 mm
 1580140
 10000 (10x1000)





AGITATEUR CAFE BOIS 110 MM
Wooden coffee stirrer
Removedor para café madera

 110x5 mm
 1580110
 10000 (10x1000)



BAGUETTES CHINOISE BOIS ENVELOPPÉES
Wooden chopsticks in envelope
Palillos chinos madera

 200 mm
 158000/C
 3000 (30x100)



BROCHETTE BOIS 150 MM
Wooden skewer
Pincho de madera

 150 mm
 WT100
 200



BROCHETTE BOIS 200 MM
Wooden skewer
Pincho de madera

 200 mm
 WT104
 200



BROCHETTE BOIS 300 MM
Wooden skewer
Pincho de madera

 300 mm
 WT102
 200



CURE-DENTS BOIS ENVELOPPÉS INDIVIDUELLEMENT
Individually wrapped wooden toothpicks
Mondadientes envase individual

 -
 WT521
 1000

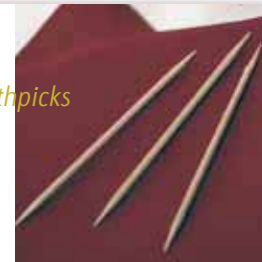

Couverts, sachets couverts et accessoires



CUILLÈRE DESSERT COULEURS VARIÉES VERT ET BLANC

Pla dessert spoon, green and white assortment
Cuchara de postre pla verde y blanca

95 mm
BIO15095
2500 (5x500)



sur commande
(to order/for encargo)

SPATULE CAFÉ PLASTIQUE BLANC

White plastic coffee stirrer
Espátula café plástico blanco

112 mm
1570112/C
5000 (5x1000)

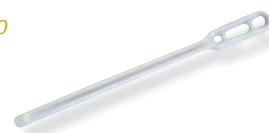

CUILLÈRE DESSERT BIODÉGRADABLE PLA

PLA biodegradable dessert spoon
Cuchara PLA

120 x 28 x 14 mm
BIO1541120
2000 (20x100)



SPATULE CAFÉ BOIS

Wooden coffee stirrer
Espátula café madera

140 mm
1580140
10000 (10x1000)



CUILLÈRE À GLACE EMBALLÉE

Individually wrapped ice cream spoon
Cuchara de postre envasada

600023
5000



AGITATEUR MULTICOLORE

Coloured swizzle stick
Removedor multicolor

170 mm
D1320
2000 (20x100)

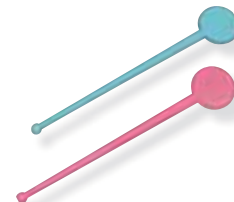

SACHET COUVERT : CUILLÈRE TRANSPARENTE 125 MM

Individually wrapped : transparent spoon
Bolsita cubiertos : cuchara transparente

125 mm
1500610T
1000



AGITATEUR CUILLÈRE TRANSPARENT

Transparent swizzle stick
Cuchara removedora transparente

178 mm
1500016
2000 (20x100)



Couverts, sachets couverts et accessoires

1 Solution tout en un 2, 3, 4, 6 ? Suivez le guide...

SACHET 1/1 : CUILLÈRE PS TRANSPARENT 125 MM

Individually wrapped : PS transparent spoon
Bolsita cubiertos : cuchara PS transparente

125 mm
1500610T
1000



SACHET 3/1 BLANC : FOURCHETTE PS + COUPEAU PS + SERVIETTE

3-In-1 pack of white cutlery : PS fork + PS knife + PS serviette
Bolsita cubiertos blancos 3 en 1 : tenedor PS + cuchillo PS + Servilleta

1500630
250



SACHET 2/1 : PETITE CUILLÈRE PS 125 MM + SERVIETTE

2-In-1 pack of cutlery : small PS spoon + serviette
Bolsita cubiertos 2 en 1 : cucharilla PS + servilleta

1500210
500



SACHET 3/1 TRANSPARENT : FOURCHETTE PS + COUPEAU PS + CUILLÈRE PS

3-In-1 pack of transparent cutlery : PS fork + PS knife + PS spoon / Bolsita cubiertos transparentes 3 en 1 : tenedor PS + cuchillo PS + Cuchara PS

1500633LT
250



SACHET 2/1 BLANC : FOURCHETTE PS + COUPEAU PS

2-In-1 pack of white cutlery : PS fork + PS knife
Bolsita cubiertos blancos 2 en 1 : tenedor PS + cuchillo PS

1506100
500



SACHET 3/1 NOIR : FOURCHETTE PS + COUPEAU PS + SERVIETTE

3-In-1 pack of black cutlery : PS fork + PS knife + serviette
Bolsita cubiertos negros 3 en 1 : tenedor PS + cuchillo PS + servilleta

1500630NOIR
250



SACHET 2/1 TRANSPARENT : FOURCHETTE PS + COUPEAU PS

Transparent cutlery sachet 2/1 : PS fork + PS knife
Bolsita cubiertos transparentes 2 en 1 : tenedor PS + cuchillo PS

1506121LT
250



Verres

Collection «Nect'Art»



FLUTE CHAMPAGNE PS TRANSP. 12 CL MONOBLOC

PS transparent champagne flute
Copa de champán PS transparente

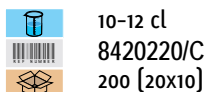

VERRE À COCKTAIL PS LIGNÉ 10 CL PIED AMOVIBLE

Transparent cocktail glass
Copa de cóctel transparente 2 piezas

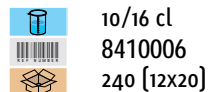

FLUTE CHAMPAGNE PS TRANSP. 7,5 CL MONOBLOC

PS transparent champagne flute
Copa de champán PS transparente



VERRE «LONG DRINK» PS

PS «LONG DRINK» glass
Vaso «LONG DRINK» PS

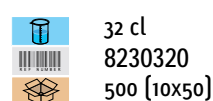

VERRE À VIN PS 10 CL

PS wine glass
Copa de vino PS

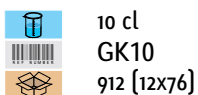

VERRE À DÉGUSTATION PS 7 CL

PS degustation glass
Vaso degustación PS

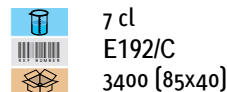

VERRE À VIN PS 17 CL

PS wine glass
Copa de vino PS



VERRE À DÉGUSTATION PS 10 CL

PS degustation glass
Vaso degustación PS

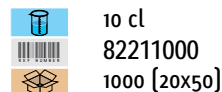

Verres

Collection «Nect'Art»

VERRE «CRISTAL» PS 20 CL

PS «CRISTAL» glass
Vaso «CRISTAL» PS



VERRE «CRISTAL» OCTOGONAL PS 25 CL

PS octagonal «CRISTAL» glass
Vaso «CRISTAL» PS

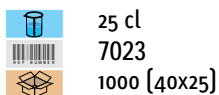

VERRE «CRISTAL» PS POUR PLATEAU PRÉSENTATION 20 CL

PS «CRISTAL» glass for display tray
Vaso «CRISTAL» PS para bandeja



FLÛTE «CRISTAL» PS POUR PLATEAU PRÉSENTATION 15 CL

PS «CRISTAL» flute for display tray
Copa de champán «CRISTAL» PS para bandeja



PLATEAU PRÉSENTATION 20 VERRES/FLÛTES PS

PS display tray for 20 glasses/flutes
Bandeja para 20 vasos/copas de champán PS

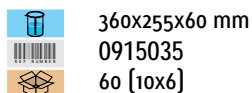

TASSE CAFE PS TRANSPARENT INJECTE

PS transparent coffee cup [injection moulded]
Taza de café PS transparente inyección

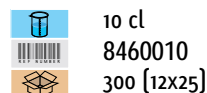

Pour compléter cette gamme,
nous vous proposons
les accessoires suivants:

SPATULE CAFÉ PLASTIQUE BLANC
[Réf. 1570112/C] Page 121



SPATULE CAFÉ BOIS
[Réf. 1580140] Page 121



AGITATEUR MULTICOLORE
[Réf. D1320] Page 121



AGITATEUR CUILLÈRE TRANSPARENT
[Réf. 1500016] Page 121



Verres

Collection «Nect'Art»



VERRE CONIQUE «KEOPS» PS

PS «KEOPS» cone-shaped glass - Vaso «KEOPS» cónico PS

noir/black/negro
Ø 6 cm - h 17 cm
12 cl
842012N
20

blanc/white/blanco
Ø 6 cm - h 17 cm
12 cl
842012B
20

transparent
Ø 6 cm - h 17 cm
12 cl
842012T
20



sur commande
to order/de encargo

PORTE-VERRES 3 «KEOPS» PS

PS holder for 3 «KEOPS» glasses
Portavasos para 3 «KEOPS» PS

15x15 cm - h 24,5 cm
0915016
6

sur commande
to order/de encargo



PORTE-VERRES 11 «KEOPS» PS

PS holder for 11 «KEOPS» glasses
Portavasos para 11 «KEOPS» PS

20x8,5 cm - h 24,5 cm
0915017
1

sur commande
to order/de encargo



VERRE À BIÈRE PP TRANSPARENT

Transparent PP beer glass
Vaso para cerveza PP transparente

25-30 cl
8460004
420 (21x20)

réutilisable



VERRE À BIÈRE PP GIVRÉ

Frosted PP beer glass
Vaso para cerveza PP mate

30-40 cl
8460006
75



VERRE «DISCO» PP

PP «DISCO» glass
Vaso «DISCO» PP

26 cl
8460002C
420

réutilisable



VERRE CONSIGNÉ PP 33CL

Returnable PP glass
Vaso retornable PP

33 cl
8911033
300 (15x20)

personnalisable



VERRE CONSIGNÉ DÉCOR PPT 33CL

Returnable PP glass with decoration
Vaso retornable decorado PP

33 cl
8911033PPT
300 (15x20)



VERRE «TUBO» PP GIVRÉ

Frosted PP «TUBO» glass
Vaso «TUBO» PP mate

26 cl
8914026
100 (10x10)

personnalisable



GOBELET PP INJECTÉ 60CL

PP glass
Vaso glaçe PP

60 cl
8911066
300 (15x20)



Dimensions
Dimensions

Capacité
Capacity

Référence
Reference



Conditionnement
Packaging

Verres

Collection «Nect'Art»





VERRE À WHISKY «PRIVILÈGE» Polycarbonate
PC «PRIVILÈGE» rocks glass
Vaso de whisky «PRIVILÈGE» PC

 25 cl
 971PC
 50

sur commande
to order/de encargo





VERRE «LONG DRINK» Polycarbonate
PC «LONG DRINK» glass
Vaso «LONG DRINK» PC

 32 cl
 968PC
 50

sur commande
to order/de encargo





FLÛTE À CHAMPAGNE Polycarbonate
PC Champagne flute
Copa de champán PC

 17 cl
 967PC
 50

sur commande
to order/de encargo





VERRE À COCKTAIL Polycarbonate
PC Martini glass
Copa de cóctel PC

 27 cl
 969PC/C1
 40

sur commande
to order/de encargo









VERRE «TULIPE» Polycarbonate
PC «TULIPE» glass
Vaso «TULIPE» PC

 30 cl
 961PC
 50

sur commande
to order/de encargo



 40 cl
 962PC
 50

 50 cl
 970PC
 50

VERRE «SHOOTER» 4 CL Polycarbonate
PS «SHOOTER» glass
Vaso «SHOOTER» PC

 4 cl
 972PC
 100



VERRE «SHOOTER» 3,4 CL Polycarbonate
PC «SHOOTER» glass
Vaso «SHOOTER» PC



 3,4 cl
 986PC
 100



réutilisable

sur commande
to order/de encargo

VERRE À WHISKY COULEUR PS
PS coloured rocks glass
Vaso de whisky de colores PS

 25 cl
 971PCR/VB
 50



VERRE À VIN PS
PS wine glass
Copa de vino PS

 15 cl
 8410004
 48

sur commande
to order/de encargo





Serviettes et nappes

SERVIETTE OUATE BLANCHE

WHITE CELLULOSE SERVIETTES - SERVILLETAS GUATA BLANCAS

SERVIETTE 30x30 CM - 1 PLI



1-ply serviette
Servilleta 1 capa

 30x30 cm
 611111/C
 4000 (20x200)



SERVIETTE 30x30 2 PLIS



2-ply serviette
Servilleta 2 capas

 30x30 cm
 611211
 3200 (32x100)



SERVIETTE 30x40 2 PLIS



2-ply serviette
Servilleta 2 capas

 30x40 cm
 611221/C
 2400 (24x100)



SERVIETTE 40x40 2 PLIS



2-ply serviette
Servilleta 2 capas

 40x40 cm
 611231/C
 2400 (24x100)



SERVIETTE 40x40 3 PLIS

3-ply serviette
Servilleta 3 capas

 40x40 cm
 611331
 1800 (36x50)

sur commande
to order/de encargo





SERVIETTE & DISTRIBUTEUR

SERVIETTES & DISPENSERS - SERVILLETAS Y DISTRIBUIDORES

SERVIETTE 25x30 1 PLI POUR DISTRIBUTEUR

1-ply serviette for dispenser
Servilleta 1 capa

 25x30 cm
 SE2530B
 10800 (36x300)



SON DISTRIBUTEUR



Serviette dispenser for SE2530B
Dispensador para SE2530B

 XCPS12
 1



SERVIETTE 33x33 1 PLI DÉCALÉ POUR DISTRIBUTEUR

1-ply serviette for dispenser
Servilleta 1 capa para dispensador

 30x33 cm
 SE3333D
 4000 (16x250)



SON DISTRIBUTEUR



Serviette dispenser for SE2530B
Dispensador para SE2530B

 XCPS13
 1



SERVIETTE 30x30 1 PLI DÉCALÉ



2-ply serviette
Servilleta 1 capa

 30x30 cm
 611112/C1
 4000 (16x250)



SON DISTRIBUTEUR



Serviette dispenser for 6110211
Dispensador para 6110211

 K89310/C
 1



SERVIETTE 30x40 2 PLIS

2-ply serviette
Servilleta 2 capas

 30x40 cm
 611221D/C
 4000

sur commande
to order/de encargo



SON DISTRIBUTEUR

Serviette dispenser for 6110211
Dispensador para 6110211

 T221063
 1



 Dimensions
Dimensions

 Capacité
Capacity

 Référence
Reference

 Conditionnement
Packaging



Serviettes et nappes

SERVIETTE OUATE COULEUR

COLOURED WADDEN NAPKINS -SERVILLETAS GUATA COLORES

SERVIETTE OUATE 30x30 cm 2 PLIS

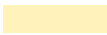
2-ply napkin - Servilleta 2 capas

	6112141	rouge / red / rojo	3000 (30x100)
	6112142	bordeaux / burgundy / burdeos	3000 (30x100)
	6112121	ivoire / ivory / marfil	3000 (30x100)
	6112123	jaune / yellow / amarillo	3000 (30x100)
	6112182/C	bleu clair / light blue / azul claro	3000 (30x100)
			



SERVIETTE DOUBLE POINT

DOUBLE POINT SERVIETTES - SERVILLETAS DOBLE PUNTO

référence suivie de * 



SERVIETTE DOUBLE POINT 38x38 CM

Double point serviette - Servilleta doble punto

	6132340/C	blanc / white / blanco	1200 (24x50)
	6132341/C	rouge / red / rojo	1200 (24x50)
	6132323*	jaune / yellow / amarillo	1200 (24x50)
	6132342/C*	bordeaux / burgundy / burdeos	1200 (24x50)
	6132343*	noir / black / negro	1200 (24x50)
	6132345*	marine / blue navy / azul marino	1200 (24x50)
	6132393/C*	vert / green / verde	1200 (24x50)
	6132349	vert anis / anise green / pistacho	1200 (24x50)
	6132348	chocolat / chocolate / chocolate	1200 (24x50)
			
			

SERVIETTE DOUBLE POINT «COCKTAIL» 20x20 CM

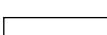

Double point «COCKTAIL» serviette
Servilleta doble punto «COCKTAIL»

	6132010	blanc / white / blanco	3000 (30x100)
	6132011	noir / black / negro	3000 (30x100)
			
			

DISTRIBUTEUR PLEXIGLAS POUR SERVIETTES «COCKTAIL» 20x20 CM

Perspex dispenser for «COCKTAIL» serviettes
Dispensador plexiglás servilleta «COCKTAIL»

sur commande
to order/de encargo

	-		
	T221025*		
	1		



Serviettes et nappes

SERVIETTE VOIE SÈCHE

«VOIE SÈCHE» ABSORBENT SERVIETTES - SERVILLETAS «VOIE SÈCHE»

référence
suivie de *

sur commande
to order / de encargo

SERVIETTE VOIE SÈCHE 40x40 CM

«VOIE SÈCHE» ABSORBENT SERVIETTE / Servilleta «VOIE SÈCHE»

	612131/C	blanc / white / blanco	600 (12x50)
	612131/C	blanc / white / blanco	600 (12x50)
	6121342*	bordeaux / burgundy / burdeos	600 (12x50)
	6121381*	bleu clair / light blue / azul claro	600 (12x50)
	6121383/C*	marine / blue navy / azul marino	600 (12x50)
	6121322/C	champagne / champagne / champán	600 (12x50)

SERVIETTE ÉCOLOGIQUE 100% FIBRE RECYCLÉE

ECOLOGICAL SERVIETTES 100% RECYCLED FIBERS
SERVILLETAS ECOLÓGICAS 100% FIBRA RECICLADA



SERVIETTE 30x30 CM 1PLI RECYCLÉ KRAFT NATURE

Recycled brown paper serviette - Servilleta reciclada kraft natural

	611113/C	kraft / brown / kraft	3200 (16x200)
	611113/C	kraft / brown / kraft	3200 (16x200)

SERVIETTE DOUBLE POINT RECYCLÉ KRAFT

Recycled double point serviette - Servilleta doble punto reciclada kraft

	6132113	33x33 cm - kraft / brown	360 (12x30)
	6132113	33x33 cm - kraft / brown	360 (12x30)
	6132313	38x38 cm - kraft / brown	900 (18x50)

sur commande
to order / de encargo



 Dimensions
Dimensions

 Capacité
Capacity

 Référence
Reference

 Conditionnement
Packaging



Serviettes et nappes

NAPPE BLANCHE EN ROULEAU

WHITE PAPER TABLE COVERS REELS - MANTEL PAPEL BLANCO EN ROLLO

NAPPE PAPIER BLANCHE EN ROULEAU

White paper table cover reel - Mantel papel blanco en rollo

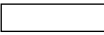
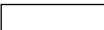
			
	20508	rouleau 1.20x10 m	25
	603330	rouleau 1.20x50 m	6
	603332	rouleau 1.20x100 m	3

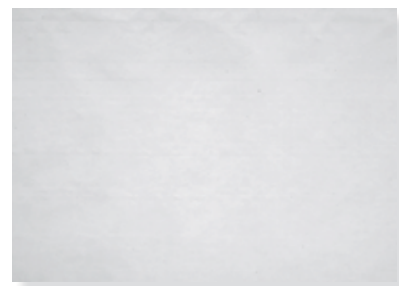







NAPPE FORMAT BLANC

WHITE PAPER FORMATS - MANTEL FORMAS BLANCO

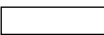
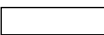
FORMAT PAPIER BLANC

White paper format - Formas papel blanco

			
	623310	carré - 60x60	500
	623510	carré - 70x70	500
	6002381	rectangle - 80x120	250
	652110	rond - Ø 80 cm	250
	652210	rond - Ø 90 cm	250
	652410	rond - Ø 110 cm	250
	652510	rond - Ø 120 cm	250



SET COULEUR

COLOURED PAPER PLACE MAT - MANTEL INDIVIDUAL PAPEL COLOR

référence suivie de * 

SET PAPIER COULEUR 30x40 CM

Coloured paper place mat - Mantel individual papel color

			
	623101	blanc / white / blanco	1000
	623111	kraft brun / brown paper / kraft	500
	623141/C	rouge / red / rojo	1000
	623123/C	jaune vif / yellow / amarillo	1000
	623122*	chocolat / chocolate / chocolate	1000
	623124*	bleu lagon / blue lagoon / azul lago	1000
	623125*	vert amande / light green / verde claro	1000
	623126*	mandarine / tangerine / mandarín	1000
	623127*	parme / parma / malva	1000
	623128*	fuchsia / fuchsia / fucsia	1000
	623129*	prune / plum / ciruela	1000



Serviettes et nappes

NAPPE VOIE SÈCHE EN ROULEAU

ABSORBENT TABLE COVERS REELS - MANTEL «VOIE SÈCHE» EN ROLLO

NAPPE «VOIE SÈCHE» ROULEAU 1,20x25 M

Absorbent table cover reel - Mantel «VOIE SÈCHE» en rollo



	632100	blanc / white / blanco	1
	632105	saumon / salmon / salmón	1
	632106	grège / oatmeal / crudo	1
	632107	champagne / champagne / champán	1
	632109	prune / plum / ciruela	1
	632111	gris / grey / gris	1
	632112	noir / black / negro	1
	632113	aubergine / aubergine / berenjena	1
	632114	cacao / cocoa / cacao	1
	632116	turquoise / turquoise / tuquesa	1
	632115	parme / parma / malva	1

NAPPE «VOIE SÈCHE» ROULEAU 1,20x50 M

Absorbent table cover reel - Mantel «VOIE SÈCHE» en rollo



	632201	blanc / white / blanco	1
	632202	rouge / red / rojo	1
	632204/C	bordeaux / burgundy / burdeos	1
	632206	bleu foncé / dark blue / azul oscuro	1
	632207	ivoire / ivory / marfil	1



NAPPE RONDE VOIE SÈCHE

ROUND DRY LAID COVER TABLES - MANTEL «VOIE SÈCHE» REDONDO

NAPPE VOIE SÈCHE RONDE Ø 240 CM

Round absorbent table cover - Mantel «VOIE SÈCHE»

sur commande
to order / de encargo



	632820	blanc / white / blanco	12
	632821	champagne / champagne / champán	12
	632822	bordeaux / burgundy / burdeos	12
	632823	bleu vif / bright blue / azul brillante	12
	632824	vert pomme / green / verde	12
	632825	cacao / cocoa / cacao	12
	632826	noir / black / negro	12



Serviettes et nappes

SURNAPPE VOIE SÈCHE

ABSORBENT TABLE COVERS - SOBREMANTEL «VOIE SÈCHE»

SURNAPPE VOIE SÈCHE 80x80 CM

Absorbent Table Cover - Sobremantel «VOIE SÈCHE»

sur commande
to order / de encargo

	632701	gris perle / pearl grey / gris perla	12
	632702	champagne / champagne / champán	12
	632708	fuchsia / fuchsia / fucsia	12
	632721	bordeaux / burgundy / burdeos	12
	632734	aubergine / aubergine / berenjena	12
	632742	cacao / cocoa / cacao	12
	632782	noir / black / negro	12

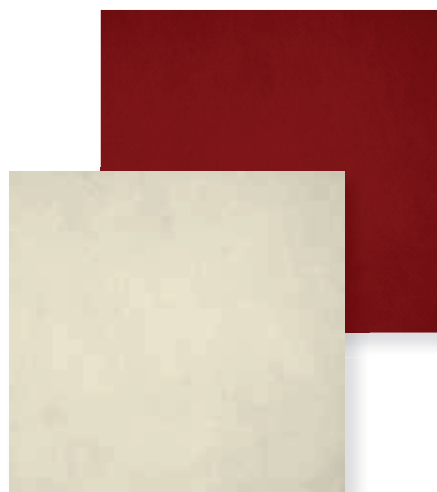

TÊTE-À-TÊTE VOIE SÈCHE ROULEAU PRÉDÉCOUPÉ

TETE-A-TETE PRECUT REEL - MANTEL PARA DOS EN ROLLO PRECORTADO

TÊTE-À-TÊTE ROULEAU PRÉDÉCOUPÉ 20 PIÈCES 0,40 x 1,20

2-Place place mat precut reel 20 items

Mantel para dos precortado 20 unidades

sur commande
to order / de encargo

	632101	blanc / white / blanco	4
	632182	champagne / champagne / champán	4
	632103	parme / parma / malva	4
	632192	gris perle / pearl grey / gris perla	4
	632183	cacao / cocoa / cacao	4
	632194	rouge / red / rojo	4
	632143	bordeaux / burgundy / burdeos	4



Dimensions
Dimensions

Capacité
Capacity

Référence
Reference

Conditionnement
Packaging

Serviettes et nappes

CHEMIN DE TABLE VOIE SÈCHE

ABSORBENT TABLE RUNNER - CAMINO DE MESA

CHEMIN DE TABLE «VOIE SÈCHE» 0,30x16 M / 0,40x10 M*
Table runner - Camino de mesa «VOIE SÈCHE

sur commande
To order / de encargo

	622902	champagne / champagne / champán	4*
	622934	gris perle / pearl grey / gris perla	4*
	622942	bordeaux / burgundy / burdeos	4
	622984	parme / parma / malva	4
	622981	rouge / red / rojo	4
	622994	cacao / cocoa / cacao	4*





JUPONNAGE NON-TISSÉ

NON-WOVEN TABLE SKIRT - FALDILLA PARA MESA SIN TEJER

JUPONNAGE NON-TISSÉ 0,72x4 M
Non-woven table skirt - Faldilla para mesa sin tejer

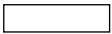
sur commande
To order / de encargo

	623150	blanc / white / blanco	4
	623151	bordeaux / burgundy / burdeos	4
	623152	champagne / champagne / champán	4
	623153	bleu foncé / dark blue / azul oscuro	4



 Dimensions
Dimensions

 Capacité
Capacity

 Référence
Reference

 Conditionnement
Packaging

Solutions transport

Les  :

- Esthétique soulignée
- Modularité
- Produit de gamme





PLATEAU «FAST FOOD»

Destiné aux fast food, les professionnels de la restauration rapide auront ainsi un plateau jetable à la fois élégant et de bonne qualité.



PLATEAU FAST FOOD CARTON DÉCORÉ MICRO CANNÉ

*Decorated fast food tray with micro-ridges
Bandeja cartón decorada microacanalada*





	268 x 200 x 30 mm
	0922620
	200
	16







Pour compléter ce plateau, nous vous proposons :

BOÎTE «TAKE AWAY» CARTON DÉCOR PASSE-PARTOUT





*All-purpose cardboard «TAKE AWAY» box
Caja cartón «TAKE AWAY» universal*

	114 x 73 x 45 mm
	333114
	750
	30



	135 x 85 x 51 mm
	333135
	750
	20







	140 x 102 x 61 mm
	333140
	450
	35







BOÎTE HAMBURGER CARTON DÉCOR PASSE-PARTOUT

*All-purpose cardboard hamburger box
Caja cartón para hamburguesa*

	97 x 97 x 70 mm
	333097/C
	300
	24



	100 x 100 x 80 mm
	333100
	600
	20



Solutions transport

Les  :

- Praticité de transport
- Empilable
- Fonctionnel

CAISSES TRAÎTEUR

Ces caisses de transport sont à la fois robustes et pratiques grâce à leurs rebords. Idéal pour le transport de vos buffets, plateaux et caisses sur mesure.

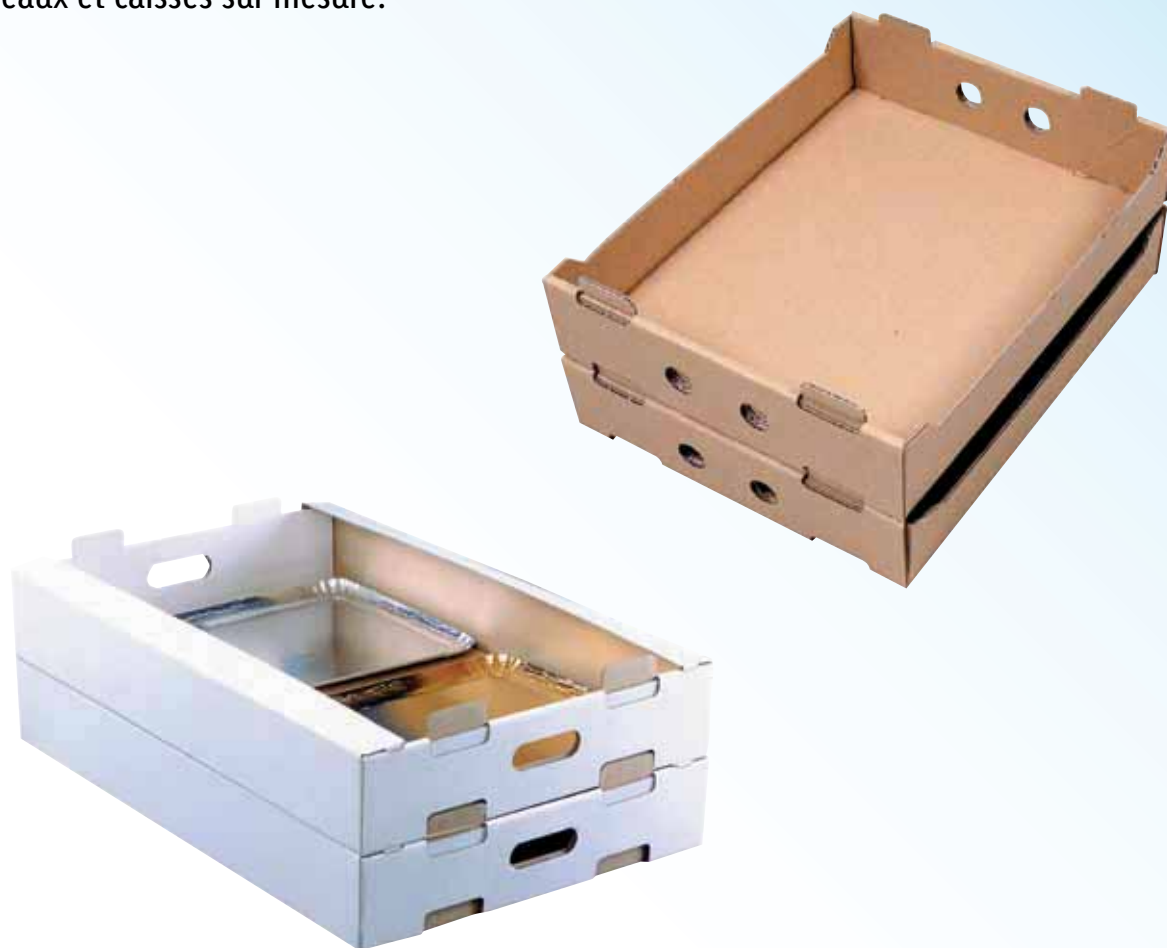

CAISSE TRAÎTEUR KRAFT BRUN

Catering box in brown cardboard
Caja comida preparada marrón



37 x 30 x 7 mm
350338KB
30
60



CAISSE TRAÎTEUR KRAFT BLANC

Catering box in white cardboard
Caja comida preparada blanca



66 x 45 x 10 mm
350336K
30
31



- Esthétique luxueuse
- Transport verrines
- Présentation verrines





PLATEAU «RÉCEPTION»





Idéal pour la présentation de pâtisseries et gâteaux sucrés ou salés tels les entremets, tartes, quiches, pizzas...
Ce plateau est recyclable.



PLATEAU CARTON OR

Gold cardboard tray - bandeja cartón dorada

	280 x 190 mm
	820105
	100
	75





	280 x 420 mm
	820101/c
	100
	50



PLATEAU CARTON ARGENT

Silver cardboard tray - bandeja cartón plateada

	280 x 190 mm
	820104
	100
	1

	280 x 420 mm
	820106
	100
	75

	100 x 160 mm
	820107
	50
	20



Solutions transport

Collection «Nect'Art»

Les  :

- Esthétique luxueuse
- Transport flûtes 15cl et verre 20cl
- Présentation et mise en valeur des produits

PLATEAU «FLÛTES»

Disposez vos flûtes dans chacun des emplacements prévus à cet effet, servez et obtenez une présentation régulière et optimale.



PLATEAU PRÉSENTATION 20 VERRES/FLUTES

Display tray for 20 glasses/flutes

Bandeja para 20 vasos/copas de champán



360 x 255 x 20 mm



0915035



60 (10x6)



24



Pour compléter ce plateau, nous vous proposons :

VERRE «CRISTAL» 20 cl POUR PLATEAU PRÉSENTATION

«CRISTAL» glass for display tray
Vaso «CRISTAL» para bandeja



20 cl



8430031



200 (10x20)



FLÛTE CRISTAL 15 cl POUR PLATEAU PRÉSENTATION

«CRISTAL» flute for display tray
Copa de champán «CRISTAL» para bandeja



15 cl



8420151



200 (10x20)



30



Solutions transport

Les  :





- Esthétique luxueuse
- Transport verrines
- Présentation verrines

«LE SUPER-POSABLE»



PLATEAU PRÉSENTATION 30 VERRINES (VENDU SANS VERRINES)

Display tray for 30 verrines (verrines sold separately)
Bandeja 30 vasitos (no incluidos)





	335X390 mm
	0915030
	48
	20



**Pour compléter ce plateau,
 nous vous proposons toutes nos verrines p.28 :**

VERRINE 5TH AVENUE TRANSPARENTE

PS «5TH AVENUE» transparent verrine
Vasito «5TH AVENUE» PS transparente

	7cl
	8430001T
	300 (10x30)
	50



VERRINE 5TH AVENUE TRANSPARENTE

PS «5TH AVENUE» transparent verrine
Vasito «5TH AVENUE» PS transparente

	7cl
	8430001TV
	500
	-



Solutions transport

Les  :



- Transport verrines
- Fenêtre et couvercle
- 6 ou 12 verrines

«LA BOÎTE DE TRANSPORT»



BOÎTE DE TRANSPORT AVEC FENÊTRE ET CALAGE POUR 12 VERRINES



Transport box for 12 verrines
Caja transporte 12 vasitos

 235x173x60 mm
 120024VGM
 25



BOÎTE DE TRANSPORT AVEC FENÊTRE ET CALAGE POUR 6 VERRINES

Transport box for 6 verrines
Caja transporte 6 vasitos



 175x123x60
 120024VPM
 25



Pour compléter ce plateau, nous vous proposons toutes nos verrines p.28 :

VERRINE «CENTRAL PARK» EN PS VERT D'EAU



PS «CENTRAL PARK» verrine
Vasito «CENTRAL PARK» PS

 7cl
 E192/C
 3400 (85x40)



VERRINE «MIAMI» PS TRANSPARENTE



PS «MIAMI» verrine - vasito «MIAMI» PS

 7-8cl
 8410009
 800 (16x50)



VERRINE «ST MORITZ» PS TRANSPARENTE





PS «ST. MORITZ» verrine
Vasito «ST. MORITZ» PS

 4-5cl
 8410008
 1000 (40x25)



VERRINE «5TH AVENUE» TRANSPARENTE PS

PS «5TH AVENUE» transparent verrine
Vasito «5TH AVENUE» PS transparente

 7cl
 8430001T
 300 (10x30)
 50



Solutions transport

Les  :



- Transport verrines
- Fenêtre et couvercle
- 6 ou 12 verrines

BOITE DE TRANSPORT

TRANSPORT BOX - CAJA TRANSPORTE

**BOITE DE TRANSPORT BLANCHE GRANDE CAPACITÉ
AVEC COUVERCLE ATTENANT**

*White transport box with attached
Caja transporte blanca con tapa*

 430x60x330 mm
 120024
 25





CALAGE

INSERTS - BANDEJAS TROQUELADAS

CALAGE 24 VERRINES

*Insert for 24 verrines
Bandeja troquelada 24 vasitos*

 430x60x330 mm
 120024V
 25



idéal avec :

E192/C



8410008



8410009





8430001T



CALAGE 12 BOLS + 6 CUILLÈRES

*Insert for 12 bowls + 6 spoons
Bandeja troquelada 12 cuencos
+ 6 Cucharas*

 430x60x330 mm
 120024B
 25



idéal avec :

13580B



40190TV





153125B



CALAGE 12 ASSIETTES COCKTAIL + 6 CUILLÈRES

*Insert for 12 mini-plates + 6 spoons
Bandeja troquelada 12 miniplatos
+ 6 Cucharas*

 430x60x330 mm
 120024A
 25



idéal avec :

13564TV



13392TV



1410088N/C1



40172N



153125B



Solutions transport

SAC CABAS

BAGS WITH HANDLES - BOLSITAS CON ASAS

personnalisable

SAC CABAS KRAFT BLANC 20/10 CM

White bag with handles
Bolsa con asas blanca

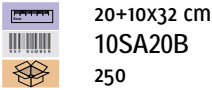

SAC CABAS KRAFT BLANC 26/18 CM

White bag with handles
Bolsa con asas blanca

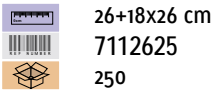

SAC CABAS KRAFT BLANC 26/14 CM

White bag with handles
Bolsa con asas blanca

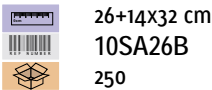

SAC CABAS KRAFT BLANC 32/20 CM

White bag with handles
Bolsa con asas blanca

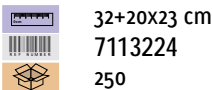

SAC CABAS KRAFT BRUN 26/18 CM

Brown bag with handles
Bolsa con asas marrón

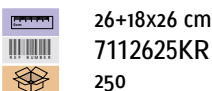

SAC CABAS KRAFT BRUN 26/14 CM

Brown bag with handles
Bolsa con asas marrón

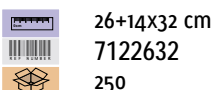

SAC CABAS KRAFT BRUN 32/20 CM

Brown bag with handles
Bolsa con asas marrón

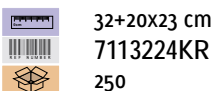

SAC CABAS KRAFT BRUN 32/15 CM

Brown bag with handles
Bolsa con asas marrón



SAC CABAS KRAFT BRUN 32/16 CM

Brown bag with handles
Bolsa con asas marrón

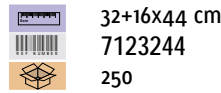

SAC À EMPORTER

TAKE-AWAY BAGS
BOLSITAS PARA LLEVAR

personnalisable

SAC À EMPORTER KRAFT BLANC

White take-away bag
Bolsa blanca para llevar

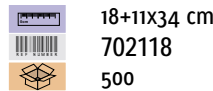

GRAND SAC À EMPORTER KRAFT BLANC

Large white take-away bag
Bolsa grande blanca para llevar



SAC À EMPORTER KRAFT BRUN

Brown take-away bag
Bolsa marrón para llevar

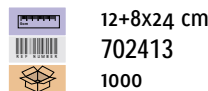

GRAND SAC À EMPORTER KRAFT BRUN

Large brown take-away bag
Bolsa grande marrón para llevar

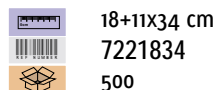

GRAND SAC À EMPORTER KRAFT BRUN

Large brown take-away bag
Bolsa grande marrón para llevar

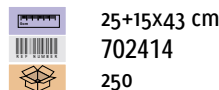

Dimensions
Dimensions

Capacité
Capacity

Référence
Reference

Conditionnement
Packaging

Création graphique

PERSONNALISATION

- Nous analysons votre cahier des charges : le type de produit à personnaliser, la quantité souhaitée, le délais, le visuel à imprimer et le nombre de couleurs.
- Nous créons pour vous les bons à tirer sur gabarit en établissant une recherche colorimétrique, formelle et typographique.
- Après validation sur épreuve papier, nous permettons à vos projets de voir le jour.



5



6



... à la personnalisation













e-commerce

MISE EN LIGNE

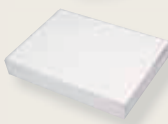
- Pour vous, nous organisons la présentation de nos produits, leur mise en situation, leurs caractéristiques techniques, leurs conditionnements et leurs «Plus».
- Nous mettons à jour l'actualité de nos produits afin de vous offrir un maximum de choix et de nouveautés.
- Enfin, nous optimisons les moteurs de recherches et les options de navigation pour faciliter votre requête.



Informations techniques matières

	CODE	MATIÈRE	TEMPÉRATURE MINI / MAXI	MICRO-ONDABLE	FOUR TRADITIONNEL	COMPOSTABLE	BIODÉGRADABLE	RECYCLABLE
	PEUPLIER	Bois	-18°C à +220°C	NON	OUI	OUI	OUI	OUI
	PIN	Bois	-5°C à +70°C	NON	NON	OUI	OUI	OUI
	PULPE	Résidu canne à sucre	-18°C à +150°C	OUI	OUI	OUI	OUI	OUI
	BAMBOU	Pohaceae (herbacé)	-5°C à +70°C	NON	NON	OUI	OUI	OUI
	PLA TRANSPARENT	Plastique acide polyactique	-18°C à +40°C	NON	NON	OUI	OUI	OUI
	CARTON	—	-40°C à +80°C	OUI	NON	OUI	OUI	OUI
	APET - PET RPET - PETE	Polyéthylène teraphtalate	-40°C à +70°C	NON	NON	NON	NON	OUI
	PP	Polypropylène	-40°C à +120°C	OUI	NON	NON	NON	OUI
	PS	Polystyrène Thermoformé	-18°C à +80°C	NON	NON	NON	NON	OUI
	PSI	Injection Polystyrène	-18°C à +80°C	NON	NON	NON	NON	OUI
	VERRE	—	0°C à +60°C	OUI	NON	NON	NON	OUI
	CÉRAMIQUE	—	-20°C à +80°C	OUI	OUI	NON	NON	NON

Conditions générales de vente

1. APPLICATION DES CONDITIONS GÉNÉRALES - DÉFINITIONS

(a) Toute vente conclue et toute commande acceptée par FIRPLAST (ci-après « le vendeur ») sont régies par les conditions particulières de vente figurant sur les offres, acceptations de commandes ou contrats de vente du Vendeur ainsi que par les présentes conditions générales de vente (lesquels documents ne pourront être modifiés que par écrit nonobstant toutes clauses contraires pouvant figurer dans les conditions particulières ou les conditions générales d'achat de l'Acheteur.

(b) Le terme « Produits » signifie les produits mis en vente par le Vendeur.

2. OFFRES

Les offres du Vendeur sont faites sous réserve que les produits offerts soient disponibles au moment de la réception de la commande de l'Acheteur.

3. ACCEPTATION DES COMMANDES

(a) Toute commande est réputée acceptée par le vendeur et constitue une vente ferme dès remises des Produits au transporteur choisi par le vendeur dans le cas où celui-ci en assure le transport ou remise à l'Acheteur ou à son transporteur si l'Acheteur assure le transport desdits Produits.

(b) Aucune vente ferme ne pourra être annulée par l'Acheteur.

4. LIVRAISON - RISQUES - TRANSPORT - RÉCEPTION

(a) Les Produits sont livrés et Vendus par le Vendeur soit franco magasin de l'Acheteur soit départ magasin du Vendeur si l'Acheteur en assure le Transport. Si la commande n'atteint pas le montant du franco prévu dans les conditions particulières de vente l'expédition donne lieu à une facturation forfaitaire.

Les produits sont transportés aux risques et périls de l'Acheteur bien que le transfert de propriété en soit différé, conformément à la Clause 7 (Réserve de propriété) ci-dessous.

(b) Pour les ventes franco magasin de l'Acheteur, le Vendeur se charge du transport et de l'assurance des Produits. L'intervention du Vendeur dans la détermination ou l'exécution du transport et dans l'assurance des Produits ne confère en aucun cas au Vendeur la qualité de commissionnaire de transport ou de transporteur.

(c) Pour les ventes départ magasin du Vendeur, l'Acheteur est responsable du transport et de l'assurance des Produits.

(d) Dans le cas où les produits sont vendus franco magasin de l'acheteur, la réception des produits par l'acheteur annule toute réclamation contre le vendeur pour dommages, avariés ou manquants, sauf si l'acheteur notifie ses réserves au transporteur par lettre recommandée avec avis de réception dans un délai de trois jours (non compris les dimanches et jours fériés) suivant la réception des produits constatée par le récépissé délivré au transporteur et qu'il adresse une copie de cette notification au vendeur dans le même délai.

(e) Dans les cas où les Produits sont vendus départ magasin du Vendeur, la réception des Produits par l'Acheteur ou son transporteur au magasin du Vendeur met un terme à toute réclamation contre le Vendeur pour dommages, avariés ou manquants, sauf si cette réclamation parvient au Vendeur par lettre recommandée avec avis de réceptions dans un délai de trois jours francs (non compris les dimanches et jours fériés) suivant ladite réception des Produits.

(f) En cas de livraison « contre remboursement » l'Acheteur doit établir le chèque au nom FIRPLAST. En aucun cas, le chèque ne doit être établi au nom du transporteur.

(g) Les produits sont livrés dans des emballages (cartons ou sachets) standards de différents modèles comprenant chacun un nombre donné d'unités de Produits. Si le nombre d'unités de produits commandées par l'Acheteur ne correspond pas au nombre d'unités contenues dans l'un quelconque des emballages standards du Vendeur, le Vendeur livrera le nombre d'unités le plus proche en fonction du conditionnement (en plus ou en moins) et l'Acheteur sera tenu d'en accepter la livraison au prix facturé pour le nombre d'unités considérées, sans pouvoir réclamer aucune indemnisation au Vendeur. Il est entendu que si le nombre d'unités livrées est inférieur au nombre d'unités commandées pour la raison indiquée ci-dessus, cette différence ne pourra en aucun cas constituer un « manquant » au sens des paragraphes (d) et (e) ci-dessus.

5. PRIX

Le prix des Produits sera celui du tarif du Vendeur en vigueur à la date de livraison. Toutefois, si ce prix excède de plus de 10 % le prix en vigueur à la date de la commande de l'Acheteur, l'Acheteur pourra, par dérogation à la Clause 3 ci-dessus, annuler sa commande, à la condition (a) qu'il retourne préalablement au Vendeur tous Produits livrés et (b) que lesdits Produits soient en parfaite condition de vente. La présente Clause 5 ne s'appliquera pas aux commandes de Produits sur lesquelles des inscriptions (« spécial print ») ou des motifs graphiques (« artwork ») spéciaux doivent être apposés à la demande de l'Acheteur.

6. CONDITIONS DE PAIEMENT

(a) Sauf clause contraire dans les conditions particulières de vente du vendeur, le prix des Produits est payable comptant (« contre remboursement ») dès la réception des Produits par l'Acheteur en ses magasins ou leur réception par l'Acheteur ou son transporteur dans les magasins du Vendeur si l'Acheteur en assure le transport.

(b) Lors d'une première commande un acompte de 50% du prix des Produits alors en vigueur est exigible à la commande.

(c) En cas de non paiement de tout ou partie du prix à son échéance ou de non acceptation d'une traite, le cas échéant, la totalité du prix des produits ou du solde restant dû deviendra, immédiatement et de plein droit, exigible, sans qu'il soit besoin au préalable d'une mise en demeure ou d'aucune procédure judiciaire et sans préjudice de la Clause 7 (Réserve de propriété) et de la Clause 10 (Résolution de la vente) ci-après.

Toute somme ou tout ou partie du prix des Produits due par l'Acheteur et non payée à sa date d'exigibilité porte intérêt de plein droit à partir de cette date et sans mise en demeure, au bénéfice du Vendeur, à un taux égal à trois fois le taux d'intérêt légal. De convention expresse et sauf report sollicité en temps et accordé par FIRPLAST, toute somme non payée à l'échéance figurant sur la facture entraîne immédiatement et de plein droit :

_ l'exigibilité des termes suivants ainsi que tout montant restant dû,

_ la suppression des avantages qui auraient pu être consentis antérieurement, et, notamment la suppression des délais de règlement accordés dans les conditions particulières,

_ l'interruption de toute livraison en cours ou à venir,

_ le droit, pour FIRPLAST, de reprendre les marchandises déjà livrées et non payées dans les conditions exposées ci après. En cas de recouvrement par voie contentieuse, les sommes dues pourront être majorées de 15%, à titre de clause pénale en sus des éventuels frais judiciaires.

Les traites impayées à leur date d'échéance seront, en outre, majorées, en cas de nouvelle présentation, des intérêts et frais occasionnés par leur retour et la nouvelle mise en circulation.

7. RÉSERVE DE PROPRIÉTÉ

Les produits restent la propriété du vendeur jusqu'au paiement complet de leur prix par l'acheteur. L'acheteur assume les risques de perte et d'avaries des produits dès leur départ du magasin du vendeur. Le vendeur aura le droit de reprendre les produits vendus, sur simple mise en demeure, si l'intégralité de leur prix (tva comprise) n'a pas été payée à sa date d'exigibilité.

8. GARANTIE

La garantie des vices cachés des Produits par le Vendeur est limitée au remplacement gratuit des Produits reconnus défectueux par le Vendeur, sous réserve de leur bon usage, à l'exclusion de tous dommages et intérêts, sauf si la garantie consentie au Vendeur par le fabriquant est moins favorable, auquel cas, cette dernière seule sera applicable à l'Acheteur.

9. RESPONSABILITÉ - DÉLAI DE LIVRAISON - CLAUSE ÉTRANGÈRE

(a) Le Vendeur s'efforce de livrer les Produits à l'Acheteur dans les meilleurs délais. Toutefois, les délais mentionnés à l'Acheteur ne le sont qu'à titre indicatif. Le Vendeur n'est donc pas responsable en cas de retard de livraison.

(b) En cas d'inexécution totale ou partielle par le Vendeur de ses obligations, la responsable du Vendeur sera limitée au préjudice direct (à l'exclusion du manque à gagner) subi par l'Acheteur du fait de cette inexécution.

(c) Le Vendeur ne sera responsable de l'inexécution totale ou partielle de ses obligations si cette inexécution résulte d'un cas de force majeure ou d'une cause qui lui est étrangère ou qui est indépendante de sa volonté même si cette cause n'a pas le caractère de force majeure (tel que, mais que cette liste soit limitative, le cas de grève, lock-out, guerre, acte de terrorisme, incendie, catastrophe naturelle, accident, embargo, réquisition, nationalisation, mesures législatives ou règlement aires promulgués par les autorités gouvernementales).

10. RÉSOLUTION DE LA VENTE

(a) Sans préjudice de ses droits selon la Clause 6 (Conditions de paiements) ou la Clause 7 (Réserve de propriété) ci-dessus, le Vendeur pourra résilier la vente des Produits en cas de non paiement par l'Acheteur, à sa date d'exigibilité, de tout ou partie de leur prix et / ou de la TVA s'y afférent ou de toute autre somme due.

(b) Sans préjudice de ses droits selon la Clause 6 (Conditions de paiements) ou la Clause 7 (Réserve de propriété) ci-dessus, le Vendeur pourra résilier la vente en cas d'inexécution par l'Acheteur de l'une quelconque de ses obligations vis-à-vis du Vendeur ou en cas de cessation des paiements, règlement judiciaire, liquidation des biens, suspension provisoire des poursuites, ou toutes procédures semblables, dissolution amiable de l'Acheteur ou, généralement, si celui-ci cesse son activité pour quelque cause que ce soit.

(c) La résolution de la vente selon cette Clause 10 sera acquise de plein droit immédiatement, par simple lettre recommandée avec avis de réception, sans mise à demeure ni procédure judiciaire préalable quelconque et le Vendeur pourra reprendre possession des Produits objet de la vente résolue, sans préjudice de tous dommages et intérêts.

11. MODIFICATION DES PRODUITS

Le Vendeur se réserve le droit de modifier les Produits, y compris leur composition et leur emballage, dans le but d'y apporter des améliorations ou de se conformer à la réglementation en vigueur.

12. EXÉCUTION DES COMMANDES

Le Vendeur ne sera pas tenu d'honorer les commandes des Produits (a) dont la production aura été définitivement interrompue ou que lui-même ou l'une des sociétés de son groupe n'aura plus le droit de fabriquer et/ou de vendre ou (b) dont la livraison serait devenue démesurément onéreuse à la suite des modifications de toute réglementation en vigueur, française ou étrangère et/ou (c) dans le cas où le Vendeur serait en liquidation ou aurait cessé toute activité. Dans les cas précédents, l'Acheteur ne pourra réclamer aucun dommage-intérêt au Vendeur.

13. ATTRIBUTION DE COMPÉTENCE

En cas de litige relatif à la vente des Produits et à ses suites, les Tribunaux de LYON seront seuls compétents même en cas de pluralité de défendeurs ou d'appel en garantie et quelles que soient les modalités de paiement.

General terms of sale

1. APPLICATION OF THE GENERAL TERMS OF SALE - DEFINITIONS

(a) Any sale concluded and any order accepted by FIRPLAST (hereinafter «the Vendor») are governed by the special terms of sale featuring on the Vendor's offers, acceptances of orders or sales agreements as well as by these general terms of sale [which documents can only be modified in writing notwithstanding all stipulations to the contrary that may feature in the Buyer's special terms or general terms of purchase].

(b) The term «Products» signifies the products sold by the Vendor.

2. OFFERS

The Vendor's offers are made provided that the products offered are available on receipt of the Buyer's order.

3. ACCEPTANCE OF ORDERS

(a) Any order is reputed to be accepted by the vendor and represents a firm sale once the Products are handed to the carrier chosen by the vendor in the event this provides the transport of these or issued to the Buyer or its carrier if the Buyer provides the transport of the aforementioned Products.

(b) No firm sale can be cancelled by the Buyer.

4. DELIVERY - RISKS - TRANSPORT - RECEIPT

(a) The Products are delivered and Sold by the Vendor either free warehouse from the Buyer or ex warehouse of the Vendor if the Buyer provides the Transport of these. If the order does not reach the sum of the carriage paid provided in the special terms of sale, shipping gives rise to a fixed invoicing.

The products are shipped at the risks and perils of the Buyer although the transfer of property is deferred, in accordance with Clause 7 (property reservation) below.

(b) For sales free warehouse from the Buyer, the Vendor is responsible for shipping and insuring Products. The Vendor's intervention in determining or carrying out the shipping and insurance of Products on no account confers to the Vendor the capacity of freight forwarder or carrier.

(c) For sales ex warehouse from the Vendor, the Buyer is responsible for shipping and insuring the Products.

(d) IN THE EVENT THE PRODUCTS ARE SOLD FREE WAREHOUSE FROM THE BUYER, THE RECEIPT OF PRODUCTS BY THE BUYER CANCELS ANY CLAIM AGAINST THE VENDOR FOR DAMAGE OR MISSING ITEMS UNLESS THE BUYER NOTIFIES THE CARRIER OF ITS RESERVATIONS BY REGISTERED LETTER WITH ACKNOWLEDGEMENT OF RECEIPT WITHIN THREE DAYS (NOT INCLUDING SUNDAYS AND BANK HOLIDAYS) FOLLOWING RECEIPT OF THE PRODUCTS ACKNOWLEDGED BY THE RECEIPT ISSUED TO THE CARRIER AND THAT IT SENDS A COPY OF THIS NOTIFICATION TO THE VENDOR WITHIN THE SAME DEADLINE.

(e) In the event the Products are sold ex warehouse from the Vendor, the receipt of Products by the Buyer or its carrier at the Vendor's warehouse ends any claim against the Vendor for damage or missing items, unless this claim reaches the Vendor by registered letter with acknowledgement of receipt within three clear days (not including Sundays and bank holidays) following the said receipt of the Products.

(f) In the event of a «cash on delivery» delivery the Buyer must make out the cheque to FIRPLAST. On no account should the cheque be made out to the carrier.

(g) The products are delivered in standard packaging (cardboard or sachets) in different models each including a given Product unit number. If the number of product units ordered by the Buyer do not correspond to the number of units contained in any of the Vendor's standard packaging, the Vendor will deliver the nearest number of units depending on the packaging (more or less) and the Buyer will be obliged to accept the delivery of this at the price invoiced for the number of units considered, without being able to claim any indemnity from the Vendor. It is understood that if the number of units delivered is less than the number of units ordered for the reason indicated above, this difference can on no account represent a «missing item» in the meaning of paragraphs (d) and (e) above.

5. PRICE

The price of the Products will be that of the Vendor's rate in force on the delivery date. However, if this price exceeds the price in force on the order date by the Buyer by more than 10%, the Buyer can, by dispensation to Clause 3 above, cancel its order provided (a) that it returns all Products delivered to the Vendor beforehand and (b) that the aforementioned Products are in perfect selling condition. This Clause 5 will not apply to orders of Products on which special inscriptions («special print») or graphical motifs («artwork») must be affixed at the Buyer's request.

6. PAYMENT TERMS

(a) Unless stipulation to the contrary under the Vendor's special sales terms the price of Products is payable cash («cash on delivery») on receipt of the Products by the Buyer in its warehouses or their receipt by the Buyer or its carrier in the Vendor's warehouses if the Buyer provides transport.

(b) During an initial order a 50% part payment of the price of the Products thus in force is payable on order.

(c) In the event of non-payment of all or part of the price on its due date or non-acceptance of a bill of exchange, if necessary, the full price of the products and the balance remaining due will become, immediately and ipso jure, payable, without a prior need to give notice or any legal proceedings and without prejudice to Clause 7 (property reservation) and Clause 10 (sale annulment) hereafter. Any amount or all or part of the price of the Products due by the Buyer and not paid on its due date bears interest ipso jure from this date and without notice, in favour of the Vendor, at a rate equal to three times the legal interest rate. With express agreement and

unless a deferral requested in time and granted by FIRPLAST, any amount featuring on the invoice not paid on the due date immediately leads to ipso jure:

_ the payability of the following terms as well as any amount remaining outstanding,

_ the withdrawal of advantages that may have been previously agreed and notably the withdrawal of payment deadlines granted under special terms

_ the interruption of all deliveries underway or to come,

_ the right, for FIRPLAST, to take back goods already delivered and not paid for under the terms set out hereafter. In the event of recovery through legal action, the sums due could be increased by 15%, pursuant to the penalty clause in addition to possible legal costs.

Bills of exchange unpaid on their due date will be, furthermore, increased in the event of a new presentation, with interest and costs incurred by their return and the new release.

7. PROPERTY RESERVATION

THE PRODUCTS REMAIN THE PROPERTY OF THE VENDOR UNTIL FULL PAYMENT OF THEIR PRICE BY THE BUYER. THE BUYER ASSUMES THE RISKS OF ANY LOSS OR DAMAGE TO THE PRODUCTS ONCE THEY HAVE LEFT THE VENDOR'S WAREHOUSE. THE VENDOR WILL HAVE THE RIGHT TO TAKE BACK SOLD PRODUCTS BY SIMPLE NOTICE IF THEIR ENTIRE PRICE (VAT INCLUDED) HAS NOT BEEN PAID ON THE DUE DATE.

8. GUARANTEE

The guarantee of hidden defects of the Products by the Vendor is limited to the free replacement of the Products recognised to be faulty by the Vendor, subject to their correct use, excluding all damages, unless the guarantee granted to the Vendor by the manufacturer is less favourable, in which case, the latter alone will be applicable to the Buyer.

9. RESPONSIBILITY - DELIVERY LEAD TIME - FOREIGN CLAUSE

(a) The Vendor endeavours to deliver the Products to the Buyer as soon as possible. However, the lead times mentioned to the Buyer are for information only. The Vendor is therefore not responsible in the event of a delivery delay.

(b) In the event of a total or partial non-performance by the Vendor of its obligations, the manager of the Vendor will be limited to direct damage (excluding loss of revenue) endured by the Buyer due to this non-performance.

(c) The Vendor will not be responsible for the total or partial non-performance of its obligations if this non-performance results from a case of force majeure or a cause that is foreign to it and independent of its will even if this cause is not force majeure (such as, but this list is not exclusive, strike, lock-out, war, act of terrorism, fire, natural disaster, accident, embargo, requisition, nationalisation, legislative or statutory measures promulgated by government authorities).

10. SALE ANNULMENT

(a) Without prejudice to its rights according to Clause 6 (payment terms) or Clause 7 (property reservation) above, the Vendor can terminate the sale of the Products in the event of non-payment by the Buyer, on its due date, of the full or partial price and/or VAT relating to it or any other sum due.

(b) Without prejudice to its rights according to Clause 6 (payment terms) or Clause 7 (property reservation) above, the Vendor can terminate the sale in the event of non-performance by the Buyer of any one of its obligations vis-à-vis the Vendor or in the event of suspension of payments, compulsory liquidation, liquidation of assets, temporary suspension of proceedings or any similar proceedings, amiable dissolution by the Buyer or, generally, if it ceases its activity for any reason whatsoever.

(c) The sale annulment according to this Clause 10 will be obtained ipso jure immediately, by simple registered letter with acknowledgement of receipt, without notice or prior legal proceedings and the Vendor can repossess the Products subject of the annulled sale, without prejudice to claim any damages.

11. PRODUCT MODIFICATION

The Vendor reserves the right to modify the Products, including their composition and packaging, with the aim of providing improvements or to comply with regulations in force.

12. ORDER FILLING

The Vendor will not be obliged to honour the orders for Products (a) the production of which will have been definitively interrupted or that itself or one of the companies of its group no longer has the right to manufacture and/or Sell or (b) the delivery of which would become excessively costly following modifications to any regulation in force, French or foreign and/or (c) in the event the Vendor is in liquidation or has ceased all activity. In the previous cases, the Buyer can claim no damages from the Vendor.

13. JURISDICTION

In the event of a dispute relating to the sale of Products and all consequential legal proceedings, the Courts of LYON will alone have jurisdiction even in the event of a multiplicity of defendants or a third-party complaint and whatever the payment terms.

Condiciones generales de venta

1/ PREÁMBULO

Las presentes condiciones generales de venta son reputadas ser conocidas y aceptadas por el comprador. El hecho de hacer un pedido, de depositar un anticipo o de coger posesión implica la aceptación formal de los presentes que logras, de manera expés, sobre la del comprador, salvo excepcion escrita y previa de nuestra parte.

2/TARIFAS

La tarifa adjunta, no es en ningún caso, una enumeración exhaustiva de los productos distribuidos por firplast, que se reserva, a todo momento, el derecho de añadir, suprimir o modificar éstos.

La tarifa es susceptible evolucionar sin preaviso, a causa de que se trata para algunos, de productos extranjeros cuyo precio es propenso a variaciones de moneda.

3/PRECIOS

Nuestros precios se entienden netos, libres de impuestos y sin descuentos, a la salida del almacén.

La tarifa es repasable a cualquier momento. Las condiciones de un presupuesto o de una oferta de precios son limitadas por una fecha de opción más allá de la cual la sociedad firplast no se hace responsable. Los precios aplicables son éstos en vigor en caso de pedido y después de confirmación por firplast.

Sin embargo, esta convenido de que el comprador sufrira el exceso de variación monetaria más allá de una diferencia de cotización del 5% entre el valor de cotización del pedido y de la entrega y eso para las monedas del país de origen respectivo de los materiales importados.

4/RESERVA DE PROPIEDAD

Según la ley 67-563 del 13 de julio de 1967 (artículo 65) y a la ley 80-335 del 12 de mayo de 1980, la propiedad de la mercancía queda reservada a firplast hasta el pago completo del precio y de sus accesorios. Se ha acordado que la entrega de cheques o de efectos equivale a pago únicamente cuando éstos hayan sido pagados completamente.

De convención expresa entre los partidos, el comprador tiene por obligación en cuanto se reciba su entrega, de asegurarse para los riesgos de pérdida o de deterioración especialmente en caso fortuito o caso de fuerza mayor.

En caso de pérdida o deterioro, el comprador tiene obligación de pagar a Firplast los daños y perjuicios, de ahora en adelante fijados a la fracción del precio impagado durante la realización del riesgo.

De esta manera, queda por obligación asegurarse ante una compañía solvente.

La indemnidad de seguro será pagada a Firplast y le tocara al comprador completarla, si se presenta el caso para alcanzar el importe de daños y perjuicios fijados a continuación:

- El comprador se compromete en asegurarse contras los daños enlazados a la guardia de los materiales y mercancías considerados estropeados o padecidos por ellos.

- El comprador se compromete en sustituirse sobre los bienes y tal y cual fijados por Firplast, todos los elementos que permitan la identificación de éstos, particularmente las placas de constructor.

- Los bienes traspasados no podrán ser revendidos sin pago previo de la totalidad del precio convenido.

De convención expresa, y no obstante toda otra disposición contraria, todas las sumas que nos hayan sido pagadas a título de adelanto, de confirmación de pedido, por letra de cambio o siguiente toda otra denominación o forma, nos serán otorgados a título concertado, incluso en caso de que la mercancía entregada nos fuese restituída totalmente intacta.

5/ TRANSPORTE Y ENTREGA

Las mercancías son reputadas entregadas una vez dirigidas en el lugar de entrega previsto durante la toma de su pedido.

La expedición da lugar a facturación forfetaria de 17€ para todo pedido inferior a 380€.

Los pedidos superiores a esta suma son entregados porte pagado. En caso de pérdida, de avería o de daño sufrido por las mercancías, le pertenece al cliente mandar tanto a Firplast como al transportista, un constante, convincente en un plazo máximo de 48 horas.

6/ VUELTA DE MERCANCÍA

En caso de entrega reconocida defectuosa por Firplast, nuestra responsabilidad se limita al cambio de la mercancía constatada defectuosa, excluyendo toda indemnización en nombre de perjuicios eventuales padecidos.

7/ CONDICIONES DE PAGO

Para cualquier cliente que no posee una cuenta abierta en nuestros libros, el pago se hace al contado acuse del recibo. Cada demanda de apertura de cuenta debiera ser acompañada para ser efectiva de un RIB (relevado d identidad bancaria) y de un KBIS.

Salvo estipulación opuesta de nuestra parte, los clientes con cuenta, deben su pago a 30 días netos. Los pagos en cuenta se efectuan mediante cheque o letra de cambio no aceptada. Los efectos de comercio deben sernos restituidos bajo 8 días.

8/ DECADENCIA DEL PLAZO

De convención expresa en caso de retraso del plazo, de préstamo, de vuelta del efecto o de retraso de pago solo de una factura, y sobre simple intimación, por carta certificada, podremos exigirle con pleno derecho el pago inmediato de todas las sumas incluso no vencidas. La aplicación de la presente cláusula nos autoriza a aplazar a toda nueva entrega y a refusarle, para cualquier nuevo pedido, el beneficio de las condiciones de pago que hayan podido ser consentidas.

9/ CLÁUSULA PENAL

En caso de no pagar las facturas en un plazo de 30 días después de una intimación, por carta certificada con acuse de recibo, quedado sin efecto unos ocho días, el cliente deberá pagar a título de las cláusulas penales (en el sentido del artículo 1229 del código civil), una indemnidad concertada fijada a 20% de las sumas restantes debidas, particularmente para tener en cuenta la perturbación causada a la tesorería de su acreedor y gastos menudos y honorarios de cobro sin que el mínimo pueda ser inferior a 76€.

En este caso, cualquier suma que quede debida, sera exigible y los pedidos pendientes podrán ser anulados.

10/ OPOSICIÓN

En caso de oposición, los juzgados de la sede son únicos competentes, cualquier sean las condiciones de venta y el modo de pago aceptado, incluso en caso de apelación en garantía de la pluralidad de los defensores.

Nos collections - Our ranges - Nuestras gamas

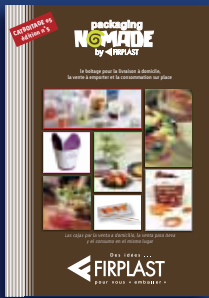

- Nomade -



- Vision Verte -

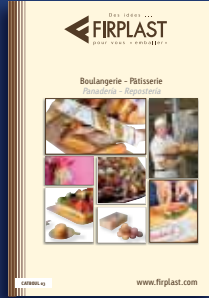

- Boulangerie Pâtisserie -

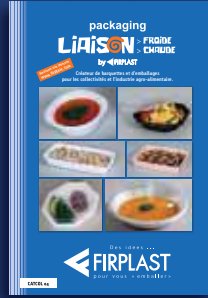

- Liaison froide -



- Gobeletterie -

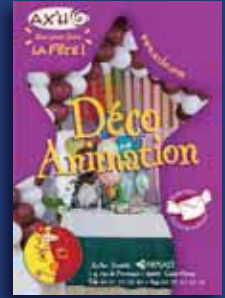

- Décoration -

Nos sites internet - Our websites - Nuestros sitios internet



www.firplast.com



www.vision-verte.com



www.axho.com



www.interface-packaging.fr

FIRPLAST LYON

4, rue de Provence - 69800 ST-PRIEST
Tél. 04 72 23 66 66 - Fax 04 78 20 54 40
contact@firplast.com - www.firplast.com

FIRPLAST MARSEILLE

2 rue de Isaïa - Les Chutes Lavie - 13013 MARSEILLE
Tél. 04 96 13 06 50 - Fax 04 96 13 06 51

FIRPLAST LANGUEDOC

MIN de Montpellier - Boîte n°16 - 281, av. du Marché Gare
34070 MONTPELLIER
Tél. 04 67 58 34 00 - Fax 04 67 58 50 37

FIRPLAST BORDEAUX

Rue Jean Raymond Guyon Z.I. - 33310 LORMONT
Tél. 05 56 31 66 57 - Fax 05 56 74 60 42

STE PAPIER RUSÉ société adhérente indépendante

32, avenue du Grugliasco - 38130 ECHIROLLES
Tél. 04 76 62 79 32 - Fax 04 76 24 44 32

LE SPÉCIALISTE DE L'EMBALLAGE GEREMBAL (Antilles)

PME - PMI de Rivière Riche - Boîte 144 - 97200 FORT DE FRANCE - MARTINIQUE
Tél. 05 96 50 78 80 - Fax 05 96 50 56 55

APPRO EMBAL

Moundong Sud 97122 Baie Mahault - GUADELOUPE
Tél. 05 90 32 78 18 - Fax 05 90 32 78 08

PINESGA BUSINESS GROUP. SL

SABADELL - BARCELONA
Tél. +34 937457193 - Fax +34 937253799 - ESPAGNE

