

MOSCA®

EXCELLENCE IN STRAPPING SOLUTIONS



Evolution SoniXs MS-6 KR

Automatic Side-Seal Strapping Machine
with Flap Frame

SONIXS MS-6 KR

MACHINE DESCRIPTION

- Ultrasonic sealing system with electronic self-calibration
- Can be integrated into most production lines
- Flap frame with magnetic locking
- High-end Standard 6 sealing unit
- Easy accessibility and tool-free disassembly of strap path components
- Dispenser variably mountable
- Hinged table top made of stainless steel
- Adjustable strap tension via control panel
- Easy operation via digital display in the control panel
- Manual strapping release via push button in the control panel
- Stepless turnable control panel (0°-180°) for many-sided operation
- 4 castors
- Extremely low energy consumption
- Frame size gradation in 200 mm steps
- Structural coating RAL 5010, gentian blue

OPTIONS

- Flexible foot switch for manual strap release
- PET dispenser (core Ø406 mm)
- Automatic adjustment of the strap tension by package height detection
- Two-part signal light
- Low strap detection with signal in the control panel
- Signal exchange via 16-pole contact plug to integrate into fully automatic production lines
- Fully automatic strap coil change by double strap dispenser
- Special conveying heights
- Special painture according to RAL scale

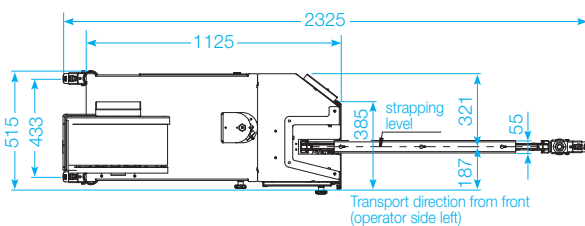

Layout Sonixs MS-6 KR (850 mm x 1400 mm)

TECHNICAL DATA

STRAPPING PERFORMANCE:

Up to 30 cycles per minute (650 mm x 800 mm)

CONVEYING HEIGHT:

170 mm to 270 mm (565 mm)
other conveying heights on request

FRAME SIZES: (freely combinable)

Widths (mm)	650	850	1050	1250	1450	1650	1850
	2050	2250	2450	2650	2850		

Heights (mm)	800	1000	1200	1400	1800	2200	2600
--------------	-----	------	------	------	------	------	------

STRAPS:

Standard machine grade 9 to 12 mm wide PP straps
(Optional) 9 x 0.54 mm to 12 x 0.54 mm wide PET straps

STRAP COIL DISPENSER:

Core diameter: 200 mm (optional 406 mm PET)
Core width: 190 mm (optional 150 mm PET)

ELECTRICITY:

Network data: 100-240 V, 50/60 Hz,
1L+N+PE
Power consumption: approx. 0.2 kW

WEIGHT:

205 kg – 300 kg

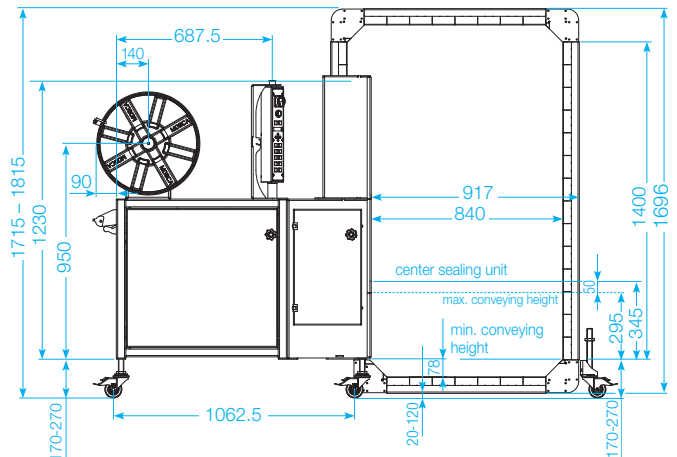

MOSCA GMBH

Gerd-Mosca-Straße 1
D-69429 Waldbrunn/Germany
Tel.: +49 6274/932-0
Fax: +49 6274/932-400 118
Tel. Tech. Service: +49 6274 / 932-146
E-Mail: info@mosca.com
Internet: www.mosca.com

10 / 16 Subject to Alterations



The models of MS-6 KR are adjustable to one strap width of all quality PP and PET straps from 9 to 12 mm. Obtainable directly from Mosca, produced in one of Europe's most modern manufacturing plants. Combinable with maintenance contracts by Mosca – a one-stop solution.