

# MOSCA®

EXCELLENCE IN STRAPPING SOLUTIONS

## EVOLUTION

The cost-efficient strapping solution



**SONIXs TAI-6 BASE**  
Fully Automatic Cross Strapping System

# SoniXs TAI-6 BASE

## THE SYSTEM CONSIST OF:

Strapping machine SoniXs TR-6 BASE  
Strapping machine SoniXs TRI-6 BASE

## STANDARD FEATURES

- Cross strapping without bundle turning
- Ultrasonic sealing system with electronic self-calibration
- Can be integrated into most production lines
- High-end Standard 6 sealing unit
- Easy accessibility and tool-free disassembly of strap way components
- Bundle positioning via increments by metrical input of the strapping positions
- Easy operation over digital display in the control panel
- TR-6 BASE: Selector switch for single, double or multiple strapping
- TRI-6 BASE: Cost-efficient, pneumatical hold-down device
- Potential-free contacts to up-stream and down-stream systems
- Open design without protective coverings - CE marking inclusive conformity declaration
- Extremely low energy consumption

## OPTIONS

- Automatic adjustment of the strap tension by package height detection
- Options TR-Base:
- Cost-efficient, pneumatical backstop
  - Cost-efficient, pneumatical hold-down device
  - Table extension up to 60, 110 or 220 mm

## TECHNICAL DATA

### PERFORMANCE:

Up to 30 packages per minute (600 x 600 mm, TR-6 BASE)  
(500 x 500 mm, TRI-6 BASE)

### STRAPS:

Standard machine grade 5 or 9 mm wide PP straps

### STRAP COIL DISPENSER:

Core diameter: 200 mm  
Core width: 190 mm

### ELECTRICITY:

Network data: 100-240 V, 50/60 Hz, 1 PH\*  
Power consumption: 0.60 kW

### WEIGHT:

805 kg (600 x 600 mm TR-6 BASE  
and 500 x 500 mm TRI-6 BASE  
incl. hold-down device and backstop)

\* Country-specific adaption possible

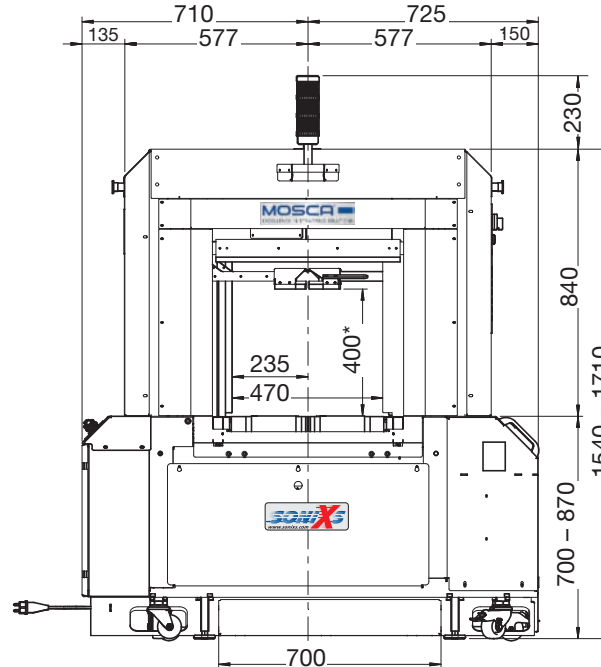
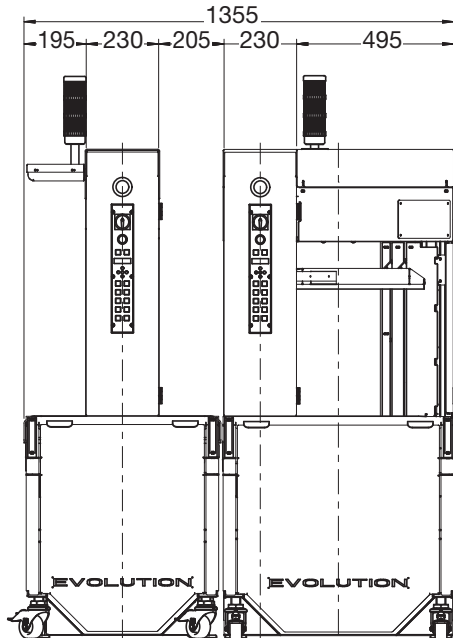

\* 400 mm by pneumatic hold-down device



**MOSCA**<sup>®</sup>  
EXCELLENCE IN STRAPPING SOLUTIONS

### MOSCA GMBH

Gerd-Mosca-Straße 1  
D-69429 Waldbrunn/Germany  
Tel.: +49 6274/932-0  
Fax: +49 6274/932-400 118  
Tel. Tech. Service: +49 6274 / 9 32-146  
E-Mail: info@mosca.com  
Internet: www.mosca.com

04/14 Subject to Alterations

The models of SoniXs TAI-6 BASE are adjustable to one strap width of all quality PP straps 5 or 9 mm. Obtainable directly from Mosca, produced in one of Europe's most modern manufacturing plants. Combinable with maintenance contracts by Mosca – a one-stop solution.

