

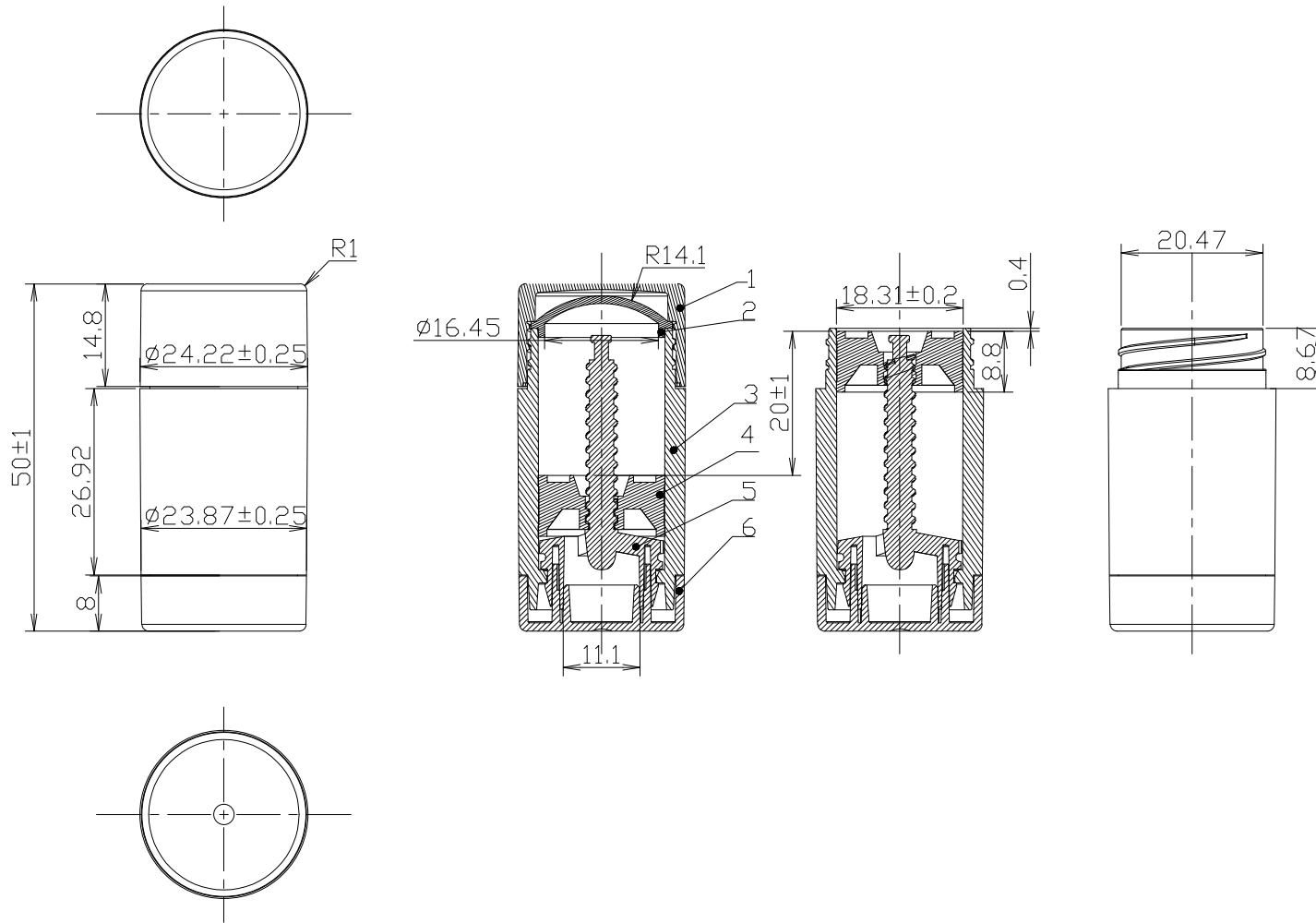
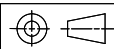

No.	NAME	Material
1	CAP	AS
2	DISC	AS
3	BODY	ABS/AS
4	CUP	PE
5	SPIRAL	PP
6	BASE	ABS/AS



4				CUSTOMER						
3				PART	ASSEMBLY					
2				NAME	PP2020002					DESIGN
1				CODE		CHECKED		APPROVED		
NO.	REVISIONS DESCRIPTION	DRAWN	DATE	SCALE	1: 1		PLATE	A4	MATERIAL	--
*Dim. are adjustable based on functional requirement		TOL.	±0.2mm	UNIT	mm [in]	DRAWING NO.	D18169	REV	00	