

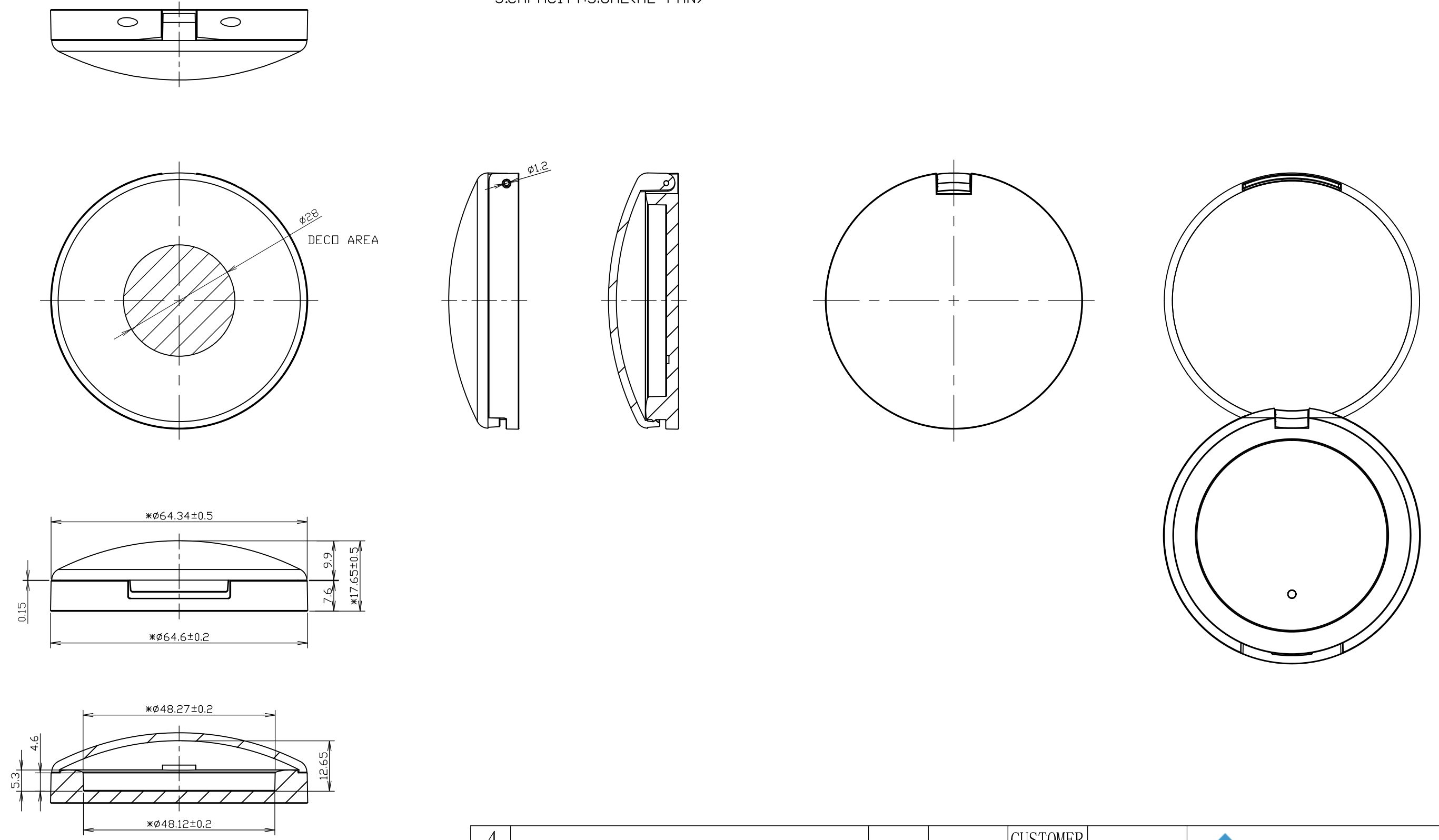

No.	NAME	Material	Drawing No.
1	COVER	SAN	D17159
2	BASE	ABS	D17174

NOTE:
 1.OPENING FORCE RANGE:0.2kgf~1kgf REF.
 2.HINGE BERAKAGE:1.8kgf MIN
 3.75cm DROP REQUIREMENT ONE TIME: NO BREAKAGE
 4.OPENING ANGLE:0°~180°
 5.CAPACITY:5.6ML(AL PAN)

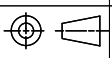

4				CUSTOMER						
3				PART	ASSEMBLY					
2				NAME	COMPACT	DESIGN	SYH	DATE	2017/12/7	
1				CODE	PC2020001	CHECKED		APPROVED		
NO.	REVISIONS DESCRIPTION	DRAWN	DATE	SCALE	1: 1		PLATE	A3	MATERIAL	---
	*Dim. are adjustable based on functional requirement	TOL.	±0.1mm	UNIT	mm [in]	DRAWING NO.	D17158	REV	00	