

NOTE:
 1.OPENING FORCE RANGE:0.5kgf~2.0kgf REF.
 2.HINGE BERAKAGE:1.8kgf MIN
 3.30"DROP REQUIREMENT: NO BREAKAGE
 4.MIRROR RETENTION FORCE:3kgf MIN
 5.OPENING ANGLE:0°~180°, STAY IN ANY POSITION
 6.GAP OF COVER&BASE:0.3mm MAX
 7.STEP OF COVER&BASE:0.3mm MAX
 8.CAPACITY:18.3ML(AL PAN)

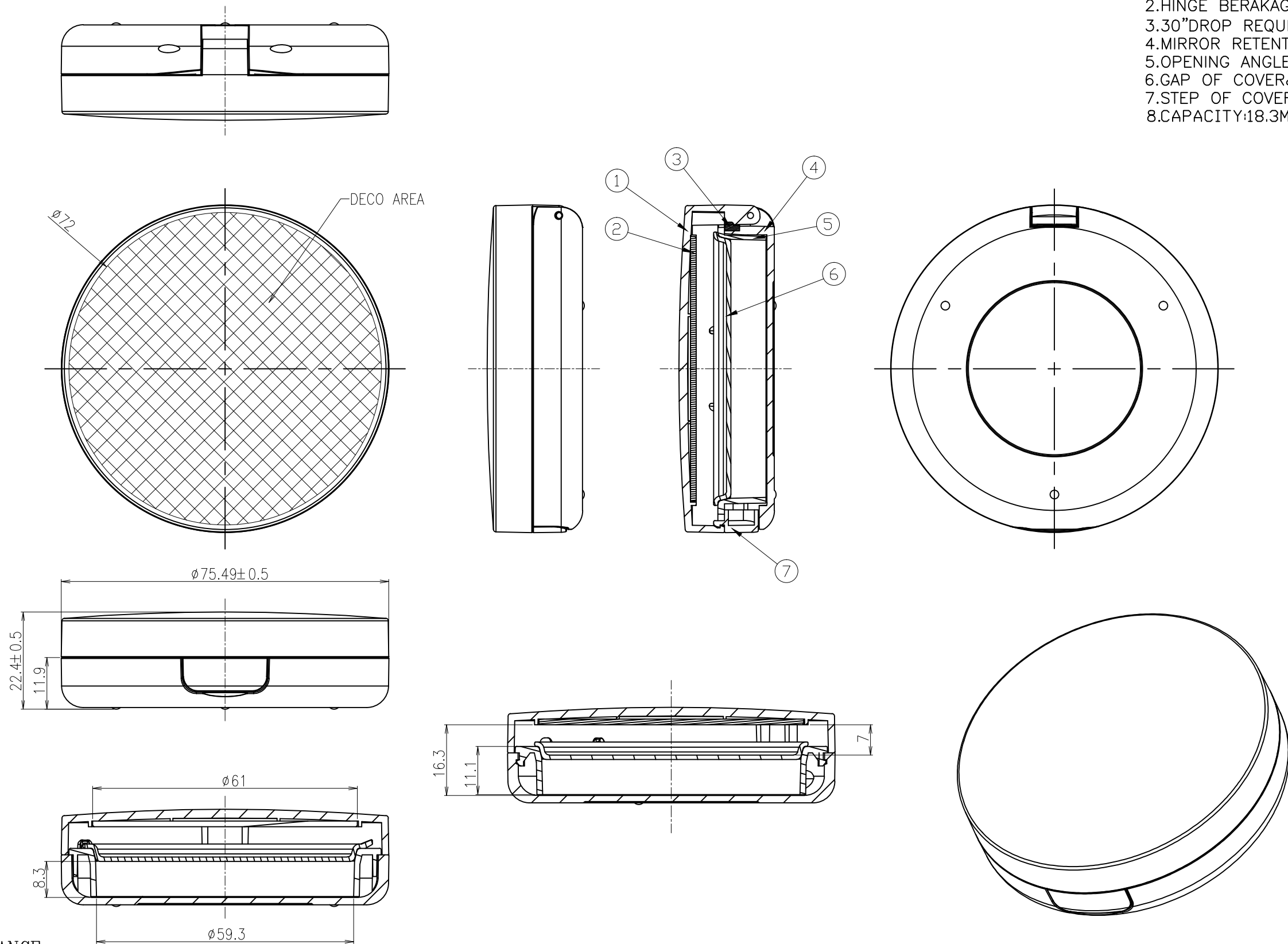

7	1	BUTTON	D15078	ABS
6	1	PLATE	D15075	PCTA
5	1	INSERT	D15074	ABS+AS
4	1	BASE	D15073	ABS+AS
3	1	RUBBER	D15072	SILICON
2	1	MIRROR	D15071	GLASS
1	1	COVER	D15070	ABS+AS
No.	Qty	Part name	Drawing No.	Material

TOLERANCE

0-6 :±0.1
 6-30 :±0.2
 30-120 :±0.3
 120-315 :±0.5
 Angle: ±0.5°
 sharp
 edges: R0.2mox

4				CUSTOMER					
3				PART	ASSEMBLY				
2				NAME	POWDER	DESIGN	Leo	DATE	15/12/7
1				CODE	PC202025	CHECKED		APPROVED	
NO.	REVISIONS	DESCRIPTION	DRAWN	DATE	SCALE	1:1	PLATE	A3	MATERIAL
	*Dim. are adjustable based on functional requirement		TOL.	---	UNIT	mm[in]	DRAWING NO.	D15079	REV 00

