

ITEM	DESCRIPTION OF REVISION	REVISED BY	DATE
⚠			

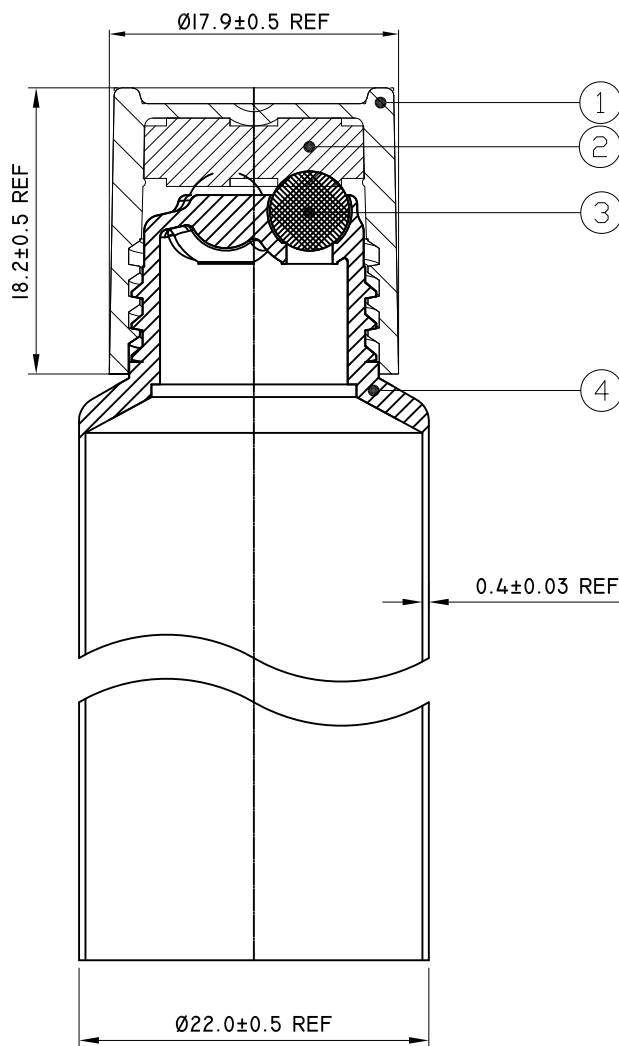
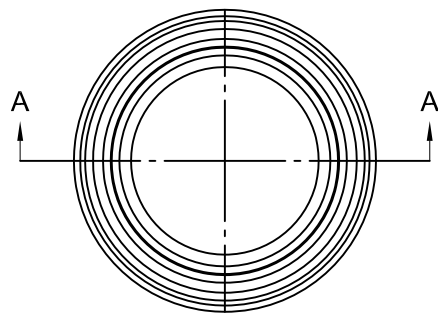

SECTION A-A

4	TUBE	D22-QQ3	PE
3	BALL	$\varnothing 5.0$	SUS
2	LINER	CS006	TPR
1	CAP	DI9-TI00UD	PP
No	PARTS	PART CODE	MATERIALS

**PROPRIETARY AND CONFIDENTIAL**

THE INFORMATION CONTAINED IN THIS DRAWING IS THE SOLE PROPERTY OF UDN INTERNATIONAL INC. ANY REPRODUCTION IN PART OR AS A WHOLE WITHOUT THE WRITTEN PERMISSION OF UDN INTERNATIONAL INC. IS PROHIBITED.

Designed **WHB** Date **2018/02/03**  
 Checked **BECK** Date **2018/02/03**  
 Approved \_\_\_\_\_ Date \_\_\_\_\_

**GENERAL TOLERANCES**

X.X  $\pm 0.2$   
 X.XX  $\pm 0.15$   
 ANGULAR X.X  $\pm 0.5^\circ$

Drawing Name: **PT2020017**

Product Name: **ASSEMBLY**

Drawing/File No. \_\_\_\_\_

Scale: 2 : 1      Material: **SEE BOM**

Unit: mm      View:

Don't Scale Drawing



ITEM	DESCRIPTION OF REVISION	REVISED BY	DATE
⚠			

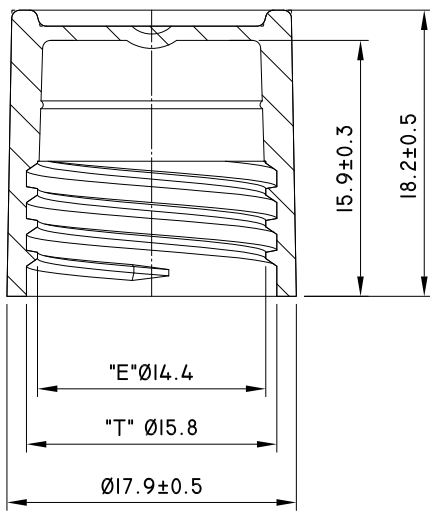
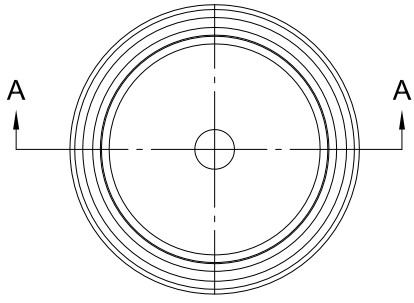

SECTION A-A

**PROPRIETARY AND CONFIDENTIAL**

THE INFORMATION CONTAINED IN THIS DRAWING IS THE SOLE PROPERTY OF UDN INTERNATIONAL INC. ANY REPRODUCTION IN PART OR AS A WHOLE WITHOUT THE WRITTEN PERMISSION OF UDN INTERNATIONAL INC. IS PROHIBITED.

Designed <b>WHB</b>	Date <b>2018/02/03</b>	Drawing Name: <b>PT2020017</b>	
Checked <b>BECK</b>	Date <b>2018/02/03</b>	Product Name <b>CAP</b>	
Approved	Date	Drawing/File No.	
GENERAL TOLERANCES X.X ±0.2 X.XX ±0.15 ANGULAR X.X ±0.5°		Scale	2 : 1
		Material	PP
		Unit	mm
		View	
Don't Scale Drawing			



ITEM	DESCRIPTION OF REVISION	REVISED BY	DATE
△			

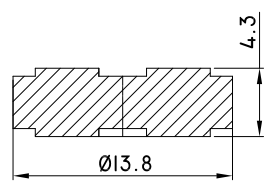
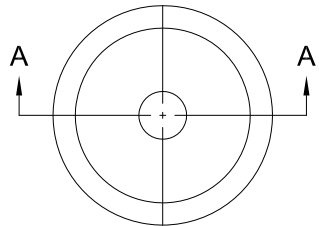

SECTION A-A

<p><b>PROPRIETARY AND CONFIDENTIAL</b></p> <p>THE INFORMATION CONTAINED IN THIS DRAWING IS THE SOLE PROPERTY OF UDN INTERNATIONAL INC. ANY REPRODUCTION IN PART OR AS A WHOLE WITHOUT THE WRITTEN PERMISSION OF UDN INTERNATIONAL INC. IS PROHIBITED.</p>	Designed <b>WHB</b> 2018/02/03	Date 2018/02/03	Drawing Name: <b>PT2020017</b>		
	Checked <b>BECK</b> 2018/02/03	Date 2018/02/03	Product Name <b>LINER</b>		
	Approved	Date	Drawing/File No.		
	<b>GENERAL TOLERANCES</b>		Scale	2 : 1	Material TPR
	X.X ±0.2 X.XX ±0.15 ANGULAR X.X ±0.5°		Unit	mm	View 
Don't Scale Drawing					



ITEM	DESCRIPTION OF REVISION	REVISED BY	DATE
△			

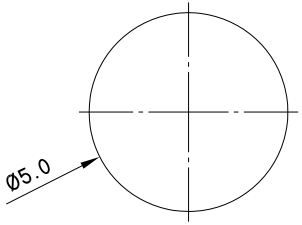

<p><b>PROPRIETARY AND CONFIDENTIAL</b></p> <p>THE INFORMATION CONTAINED IN THIS DRAWING IS THE SOLE PROPERTY OF UDN INTERNATIONAL INC. ANY REPRODUCTION IN PART OR AS WHOLE WITHOUT THE WRITTEN PERMISSION OF UDN INTERNATIONAL INC. IS PROHIBITED.</p>	Designed <b>WHB</b> 2018/02/03	Drawing Name:	Ø5.0			
	Checked <b>BECK</b> 2018/02/03	Product Name	BALL			
	Approved	Drawing/File No.	<b>PT2020017</b>			
	GENERAL TOLERANCES	Scale	5 : 1	Material	SUS	
		Unit	mm	View		
	X.X ±0.2 X.XX ±0.15 ANGULAR X.X ±0.5°	Don't Scale Drawing				



ITEM	DESCRIPTION OF REVISION	REVISED BY	DATE
⚠			

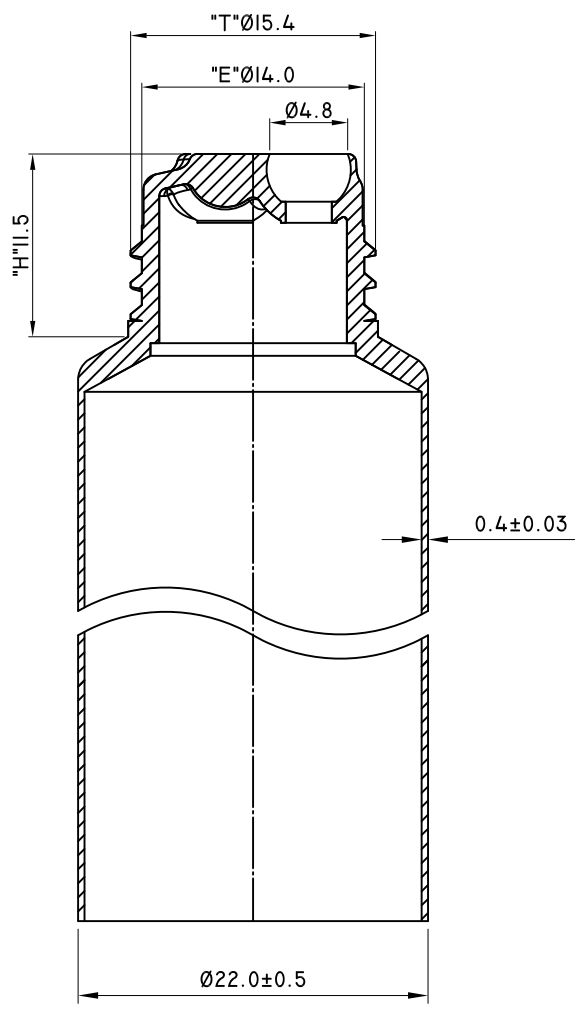
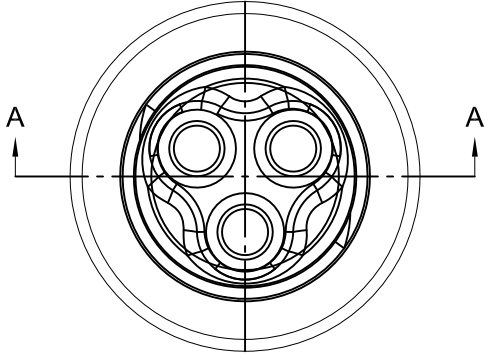

SECTION A-A

<p><b>PROPRIETARY AND CONFIDENTIAL</b></p> <p>THE INFORMATION CONTAINED IN THIS DRAWING IS THE SOLE PROPERTY OF UDN INTERNATIONAL INC. ANY REPRODUCTION IN PART OR AS A WHOLE WITHOUT THE WRITTEN PERMISSION OF UDN INTERNATIONAL INC. IS PROHIBITED.</p>	Designed <b>WHB</b> 2018/02/03	Date 2018/02/03	Drawing Name: <b>PT2020017</b>		
	Checked <b>BECK</b> 2018/02/03	Date 2018/02/03	Product Name <b>TUBE</b>		
	Approved	Date	Drawing/File No.		
	<b>GENERAL TOLERANCES</b>		Scale	2 : 1	Material <b>PE</b>
	X.X ±0.2 X.XX ±0.15 ANGULAR X.X ±0.5°		Unit	mm	View 
Don't Scale Drawing					