



DECOLINE II

Inline Coating System for
3-Dimensional Parts

DECOLINE II

*Inline Coating of 3-Dimensional Parts
for both Decorative and Functional Applications*

SINGULUS TECHNOLOGIES – Innovations for New Technologies

SINGULUS TECHNOLOGIES (SINGULUS®) develops technologies for economical and resource-efficient production processes. The core competencies are vacuum thin-film technologies, wet-chemical processes, surface technologies and thermal processing technologies. SINGULUS TECHNOLOGIES taps new work areas with these competencies and develops innovative solutions. For all processes and applications, SINGULUS TECHNOLOGIES uses its know-how to continually improve both automation and process technologies as well as the integration of production steps and cultivates methods to transfer these solutions to additional areas of application.

SINGULUS TECHNOLOGIES works on expanding this expertise in the existing segments to new markets and develops new ideas for innovative product solutions. SINGULUS TECHNOLOGIES is one of the world's leading drivers of innovations for technologic areas with high growth potential. This includes renewable energies, the entire area of entertainment, ever increasing mobility, semiconductor technologies, medical as well as consumer goods of various kinds.



DECOLINE II

*Inline Coating System
for 3-Dimensional Parts*



DECOLINE II – Enhanced Metallic Layers on 3-Dimensional Parts

Whether in the cosmetics sector or the automotive sector – metallic quality surfaces are needed more than ever in the decorative sector. However, the coating of sensitive hardware is usually an expensive step. A new, fully automated PVD coating inline system is able to operate directly from the bigpack to the finished product, saving time-consuming manual work. This is especially true for high-end cosmetic products as processes in bulk are not always possible, nor desirable from a surface protection standpoint.

SINGULUS TECHNOLOGIES offers the second generation of inline coating solutions for fully automated handling and coating of 3-dimensional parts. From loading to packaging, the process is fully automated and not one manual step is necessary – at a cycle time of only 0.4 seconds per component. This manufacturing solution is interesting for automotive, consumer goods, sanitary, mobile phones and packaging used in the cosmetics or beverage industry.

The DECOLINE II distinguishes itself with versatile options in realizing different layer configurations. Not only decorative, but also functional layers could be applied. Thinkable approaches are antibacterial coatings, EMV-shielding, electrical conductive layer (e.g. on electroplating components before the actual electroplating) or antennas. Each electrical conductive and non-magnetic metal and its alloys can be used as a metallic layer. This is a clear unique selling point, compared to batch processes, in which the selection of possible coating materials is much more limited.

The new DECOLINE II inline coating system is the next developmental level in vacuum coating and product handling:

- Brilliant layers on 3-dimensional parts
- Individual design variety
- Elimination of batch processes
- UV-curing for protection lacquer
- Inline spray coating & metallization
- Fully automated processing
- High productivity and flexibility
- Low cost of ownership
- Environment-friendly



DECOLINE II

Inline Coating of 3-Dimensional Parts



Loading station with automatic roboter sorting

Main Process Steps



Basic Concept of DECOLINE II

The different spray coating modules and the vacuum sputtering module of the DECOLINE II are interlinked by an innovative flexible inline concept. The DECOLINE II distinguishes itself from the traditional batch processes and satisfies with its inline concept all the prerequisites to revolutionize the existing production of 3-dimensional parts. By using high-quality coatings the decorative and functional properties of the coatings are significantly improved.

Base Coat Lacquering System

- UV-base lacquering system
- Solvent allowance up to 50 %
- 6-axis painting robots, up to two 6-axis painting robots per painting booth possible
- Fast production change
- Flexible IR and UV configuration
- Primer coat extension possible
- Recycling of lacquering material possible
- Significant cost reduction by most efficient material consumption

3-Dimensional Sputtering

- Cycle time per carrier: down to 6 seconds
- Up to 18 parts on one carrier
- Part rotation during sputtering process
- Bottom edge metallization
- Equipped with two cathodes in L-shape
- Target materials e.g.: Al, Cu, Cr, Zr, CuAl, Ag, Au, Stainless Steel
- Different gold color targets available
- Perfect layer uniformity and high deposition rates, even on complex 3-dimensional substrate shapes
- Reliable and clean sputtering process
- Highest coating quality, high uptime and no environmental impact
- Chromium VI-free applications

Top Coat Lacquering System

- UV-base lacquering system
- Clear lacquer application
- Colored lacquer application
- Solvent allowance up to 50 %

- 6-axis painting robot
- Fast production change
- Flexible IR and UV configuration
- Recycling of lacquering material possible
- Significant cost reduction by most efficient material consumption

DECOLINE II automates the production process while considerably reducing costs, logistical efforts as well as the personnel intensity and therefore yields a return on investment in a very short period of time.

Great Individual Design Variety

- Wide range of different target materials e.g. Al, CuAl, Cr, Ag, Au, and stainless steel
- Different gold color targets available
- UV-curable monocure top coat lacquers from high glossy and matt finish surfaces
- UV-curable monocure lacquers compatible with pigments or dyes for colored base and top coat finishing
- UV-curable monocures from different lacquer suppliers qualified
- Wide process window for different substrate shapes and layer thicknesses
- All UV-curable monocure lacquers are printable with pad printing (tampon printing) or hot stamping foil
- Gradient lacquering with second 6-axis painting robot possible

Effective, Economical, Flexible

- Inline metallization and spraying technology
- Flexibility of design and appearance of finished products
- Different materials can be metallized and lacquered, e.g. plastics, glass, metal or ceramics
- Production tool with modular configuration

Human Responsibility

- Separation of lacquering, metallization and transportation area
- Easy human operation interface
- Remote service tool



Lacquering station



Substrate transport

Controlled, Precise, Intelligent

- Fully automated production tool with integrated process control
- Compact process modules with innovative media and process management
- Flexible and robust substrate transport system
- Consistent flow conditions from process step to process step
- Easy change of sputter layer thicknesses
- Universal handling and clip system, flexible and fast change of production

Clean, Safe, User-friendly

- Safe for operators, environmental and reliable process
- Fully integrated loading/unloading for all process modules
- Reliabile and clean sputtering process, highest coating quality, high uptime and no environmental impact
- Compact spray coating module, capable for primer/base coat, colored and/or scratch resistant/top coat lacquer
- Integrated SINGULUS developed UV-lamps
- Collection and direct recycling of over spray possible
- Quick-change lacquer supply tank for lacquer color changes: Highest uptime and productivity by offline cleaning of lacquer supply tank
- Excellent accessibility of the process chamber modules and chambers from all sides through the separation of process and installation modules
- Optional painting robots for plug and play production



Sputtering system (POLYCOATER) with transport conveyors



Unloading station directly after top coating

Pre-treatment with plasma flaming

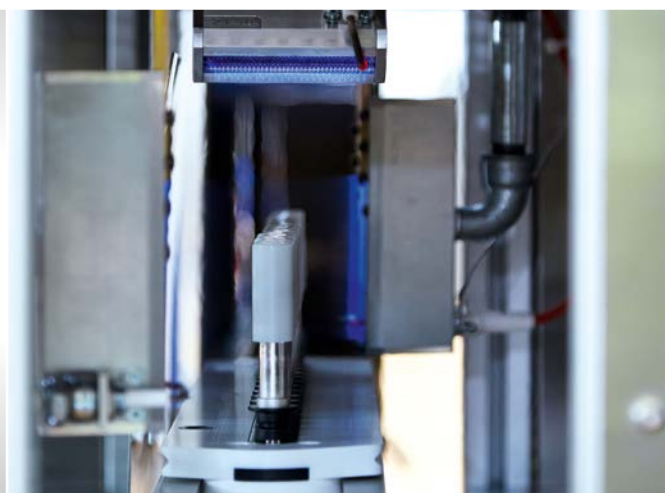
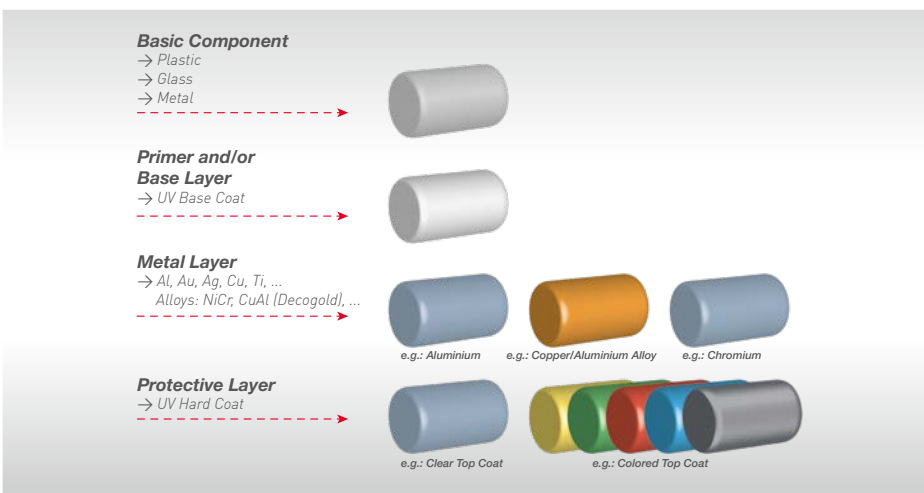

DECOLINE II

Inline Coating with Different Loading Versions

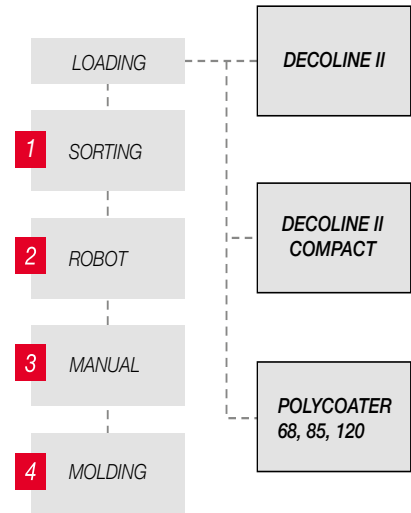

DECOLINE II

Technical Data

Throughput	up to 10,900 p/h, depending on process
Metallizer Yield	> 95 %
Breakage	< 0.2 %, depending on process
Uptime	> 95 %, depending on process
Length	approx. 18.0 m
Width	approx. 11.0 m
Height	approx. 3.8 m

Other layouts on request

*Down to
6 Seconds
Carrier
Cycle Time*

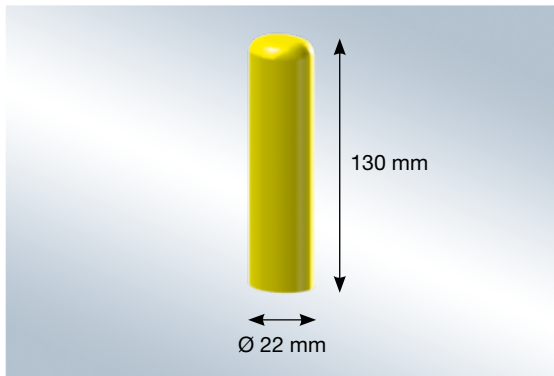

Max. 18 Parts

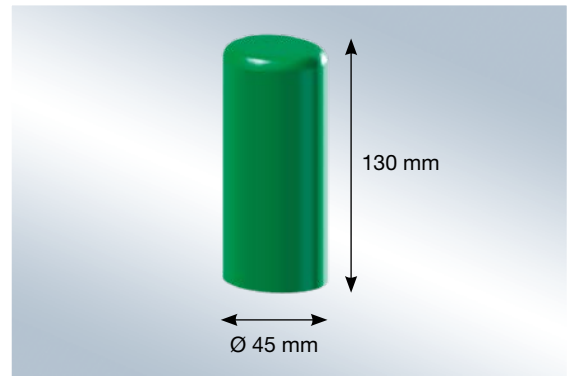

Max. 9 Parts

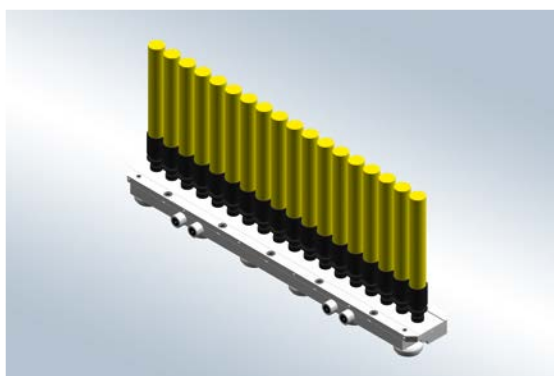

**Carrier equipped with 18 substrates,
up to 10,800 parts/h**



**Carrier equipped with 9 substrates,
up to 5,450 parts/h**

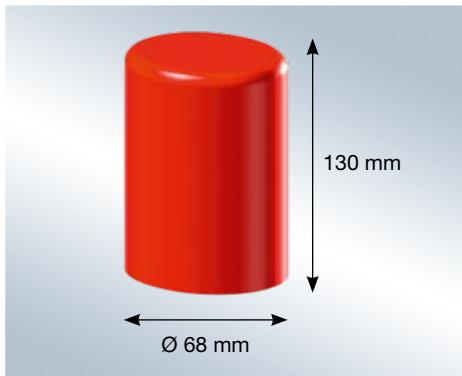
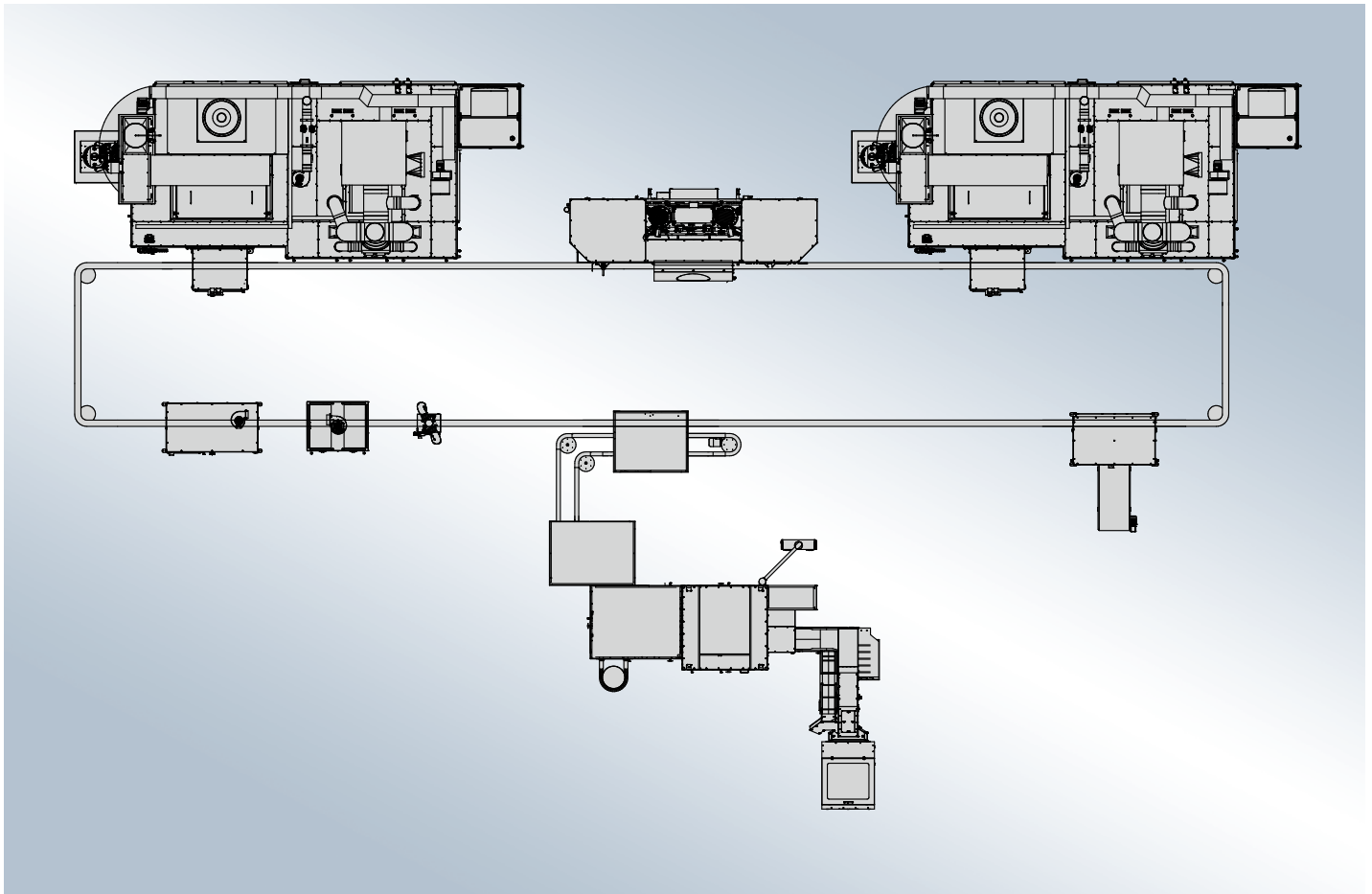

Max. 6 Parts

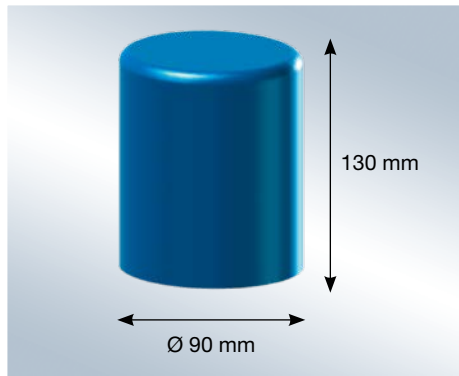

Max. 4 Parts

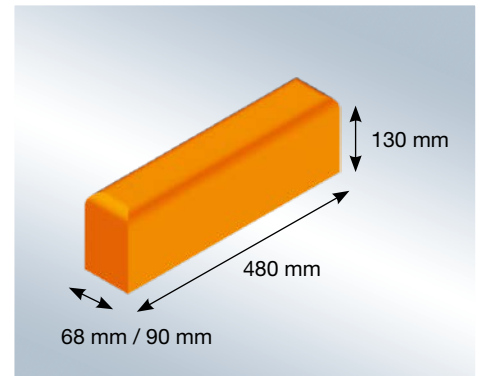

Max. Process Area

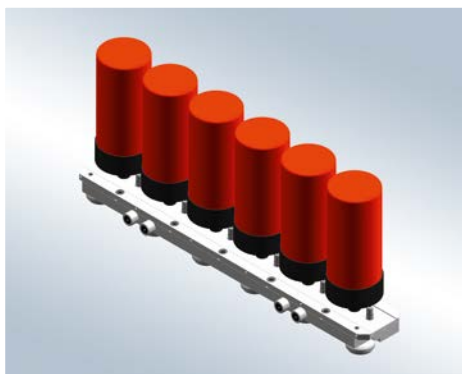

Carrier equipped with 6 substrates,
up to 3,600 parts/h

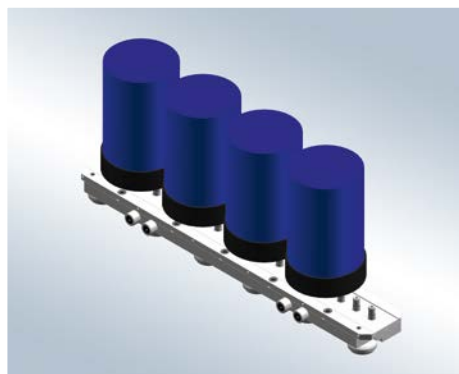

Carrier equipped with 4 substrates,
up to 1,140 parts/h

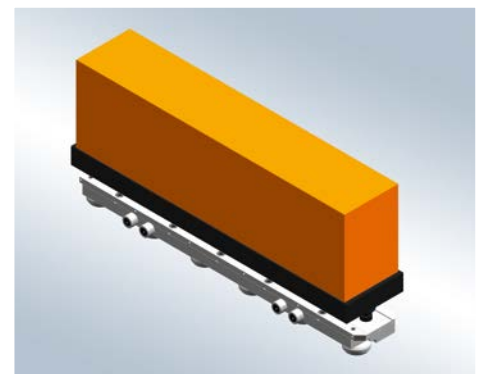

6 to 10 sec./Area | 600 to 360 Areas/h



Headquarters

SINGULUS TECHNOLOGIES AG
Hanauer Landstrasse 103
63796 Kahl, Germany
Tel. +49 6188 440-0
Fax +49 6188 440-1130
sales@singulus.de
www.singulus.de

Production Site for Wet Processing Systems

SINGULUS TECHNOLOGIES AG
Branch Office Fuerstenfeldbruck
Fraunhoferstr. 9
82256 Fuerstenfeldbruck, Germany
Tel. +49 8141 3600-0
Fax +49 8141 3600-2100
sales@singulus.de

Subsidiaries

China
SINGULUS TECHNOLOGIES CHINA
Room B412-413,
No. 1400 Jiangchang Road,
Jingan District, Shanghai, China
Zip Code: 200072
Tel. +86 21 61073997

Contact: Greens Pan
Tel. +86 13822138376
greens.pan@singulus.com.cn

France

**SINGULUS TECHNOLOGIES
FRANCE S.A.R.L.**
Tel. +33 3 893111-29
singulus@club-internet.fr

Latin America

**SINGULUS TECHNOLOGIES
LATIN AMERICA LTDA.**
Tel. +55 1121 6524-10
sales@singulus.com.br

Singapore/South East Asia

**SINGULUS TECHNOLOGIES
ASIA PACIFIC PTE LTD.**
Tel. +65 674 119-12
sales@singulus.com.sg

Taiwan, China

**SINGULUS TECHNOLOGIES
TAIWAN LTD.**
Tel. +886 2 8692-6996
sales@singulus.com.tw

United States, Mexico and Canada

SINGULUS TECHNOLOGIES INC.
Tel. +1 860 68380-00
sales@singulus.com



THIN FILM
DEPOSITION

SURFACE
ENGINEERING

THERMAL
PROCESSING

WET
CHEMICAL

SINGULUS TECHNOLOGIES – Technologies for a Sustainable World

Responsible and sustainable corporate governance is very important to SINGULUS TECHNOLOGIES. SINGULUS TECHNOLOGIES develops and assembles innovative machines and systems for efficient and resource-saving production processes, which are used worldwide in the solar/hydrogen, semiconductor, medical technology, consumer goods and data storage sectors. SINGULUS TECHNOLOGIES regards sustainability as an opportunity to position itself with innovative products that follow this spirit. In the focus are:

- environmental awareness
- efficient use of resources
- avoidance of unnecessary CO₂ pollution

The company's core competencies include various processes of coating technology, surface treatment and wet-chemical and thermal production processes.